

UTILITARIOS

PTH 1500/1800

Código: 0501093532

Serie: S-0123

Revisión: 00

Fecha de Revisión: JULHO/2023

CATALOGO DE PARTES



MARCHESAN



PRODUCTOS

Código	Descripción
0106060069	PTH 1500 DEH S-0123
0106060067	PTH 1500 DEM S-0123
0106060070	PTH 1800 DEH S-0123
0106060068	PTH 1800 DEM S-0123

ATENCIÓN: IMPORTANTE

Marchesan S.A. se reserva el derecho de perfeccionar y/o cambiar las características técnicas de sus productos, sin previo aviso y sin la obligación de proceder con los ya comercializados y sin conocimiento previo del revendedor o consumidor. Las fotos son únicamente ilustrativas.



ÍNDICE

0909096717	PTH 1500/1800	1
0531045083	VIGA PRINCIPAL - (DEM/DEH)	2
0541050163	SOPORTE RASCADOR - 1500	3
0541050162	SOPORTE RASCADOR - 1800	4
0531045091	CILINDRO HIDRÁULICO 2 X 4 X 179,	5
0541050223	CILINDRO HIDRÁULICO 2 X 4 X 77,5	6
0541050233	CILINDRO HIDRÁULICO 2 X 4 X 106	7
0541050234	MONTAJE DEL REGISTRO DE SALIDA PARA MANGUERA	8
0541050235	JUEGO DE MANGUERAS - (DEH)	9
0541050236	JUEGO DE MANGUERAS - (DEM)	10

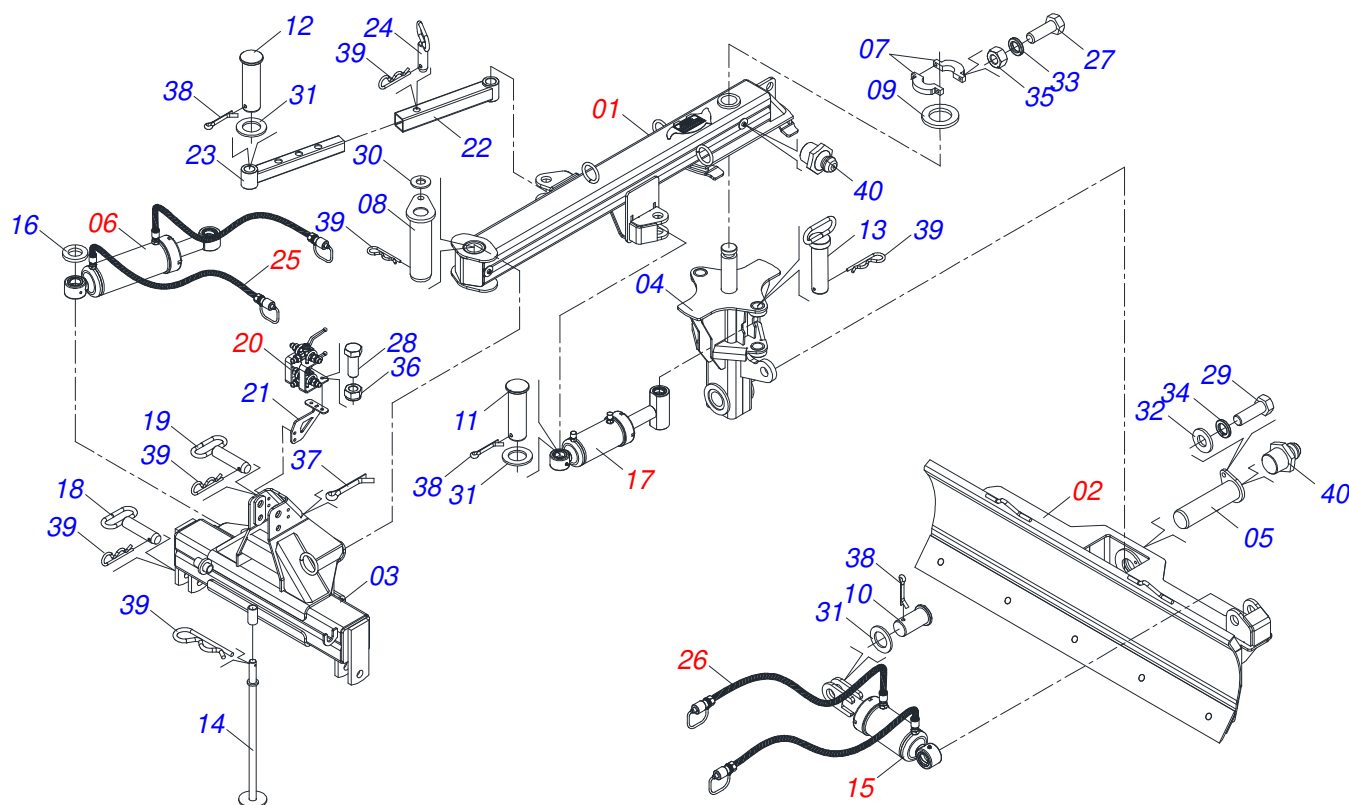

Artículo	Código	Descripción	Ver Pág.	1500M	1500H	1800M	1800H
01	0531045083	VIGA PRINCIPAL - (DEM/DEH)	2	01	01	01	01
02	0541050163	SOPORTE RASCADOR - 1500	3	01	01	00	00
02.	0541050162	SOPORTE RASCADOR - 1800	4	00	00	01	01
03	0531066223	CHASIS FRENTE		01	01	01	01
04	0531066227	TUBO CENTRAL GIRATORIO		01	01	01	01
05	0531066229	EJE DE UNIÓN 59 X 212		01	01	01	01
06	0531045091	CILINDRO HIDRÁULICO 2 X 4 X 179,	5	01	01	01	01
07	0501311902	ABRAZADERA DE FIJACIÓN DE TUBO CENTRAL		02	02	02	02
08	0531066230	EJE DE UNIÓN		01	01	01	01
09	0501311855	ARANDELA PLANA		01	01	01	01
10	0501311905	EJE DE UNIÓN		01	01	01	01
11	0501311906	EJE DE UNIÓN		02	02	02	02
12	0501311907	EJE DE UNIÓN		02	02	02	02
13	0531066231	EJE DE UNIÓN		01	01	01	01
14	0531066232	BASE DE SOPORTE		01	01	01	01
15	0541050223	CILINDRO HIDRÁULICO 2 X 4 X 77,5	6	01	01	01	01
16	0501311913	ARANDELA PLANA 40 X 72 X 9,5		00	04	00	04
17	0541050233	CILINDRO HIDRÁULICO 2 X 4 X 106	7	00	01	00	01
18	0531066233	EJE DE UNIÓN 27,8 X 110		02	02	02	02
19	0531066234	EJE DE UNIÓN 25 X 132		01	01	01	01
20	0541050234	MONTAJE DEL REGISTRO DE SALIDA PARA 8 MANGUERA		00	01	00	01
21	0511072121	SOPORTE DE REGISTRO BASE DE FIJACIÓN		00	01	00	01
22	0531066235	TUBO TELESCÓPICO CON CASQUILLO - (DEM)		01	00	01	00
23	0531066228	TUBO TELESCÓPICO CON CASQUILLO - (DEM)		01	00	01	00
24	0531066312	EJE DE UNIÓN		01	00	01	00
25	0541050235	JUEGO DE MANGUERAS - (DEH)	9	00	01	00	01
26	0541050236	JUEGO DE MANGUERAS - (DEM)	10	01	00	01	00
27	0503010397	TORNILLO 5/16" UNC X 1.3/4"		02	02	02	02
28	0503010237	TORNILLO 3/8 UNC X 1		00	04	00	04
29	0503010920	TORNILLO 1/2 UNC X 1.1/2 C S G.5 ZN		01	01	01	01
30	0591011409	ARANDELA PLANA 16,5 X 35 X 3,00		01	01	01	01



PTH 1500/1800

PTH 1500/1800

Página 1

0909096717

Artículo	Código	Descripción	Ver Pág.	1500M	1500H	1800M	1800H
31	0501012916	ARANDELA PLANA 40 X 66 X 4,75 ZN		05	05	05	05
32	0501010937	ARANDELA PLANA 13,50 X 28 X 3,00		01	01	01	01
33	0503010179	ARANDELA PRESION 5/16 ZN 1K01528		02	02	02	02
34	0503010019	ARANDELA PRESION 1/2"		01	01	01	01
35	0503010337	TUERCA 5/16		02	02	02	02
36	0503013357	TUERCA 3/8 NC		00	04	00	04
37	0503010300	PASADOR ABIERTO 5/32" X 1"		01	01	01	01
38	0503012267	PASADOR ABIERTO 5/16" X 3"		05	05	05	05
39	0503031035	PASADOR (GRAPA DE SUJECION)		06	05	06	05
40	0503010002	GRASERA 1800		03	03	03	03

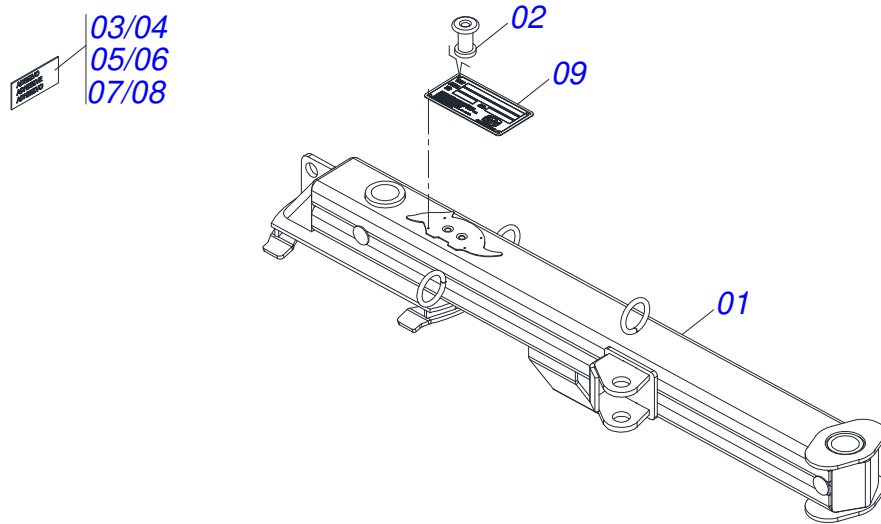

Artículo	Código	Descripción	Ver Pág.	QT
01	0531066224	VIGA PRINCIPAL		01
02	0503010001	REMACHE POP		04
03	0503031087	ETIQUETA ADHESIVA		01
04	0503034078	ETIQUETA ADHESIVA PUNTOS DE ELEVACIÓN		01
05	0503031852	ETIQUETA ADHESIVA		01
06	0503036239	ETIQUETA ADHESIVA ATENCION FLUIDOS CON PRESION		01
07	0503033428	ETIQUETA ADHESIVA		01
08	0503060910	JUEGO DE ETIQUETAS ADHESIVAS		01
09	0503034003	ETIQUETA IDENTIFICACIÓN ALUMINIO		01

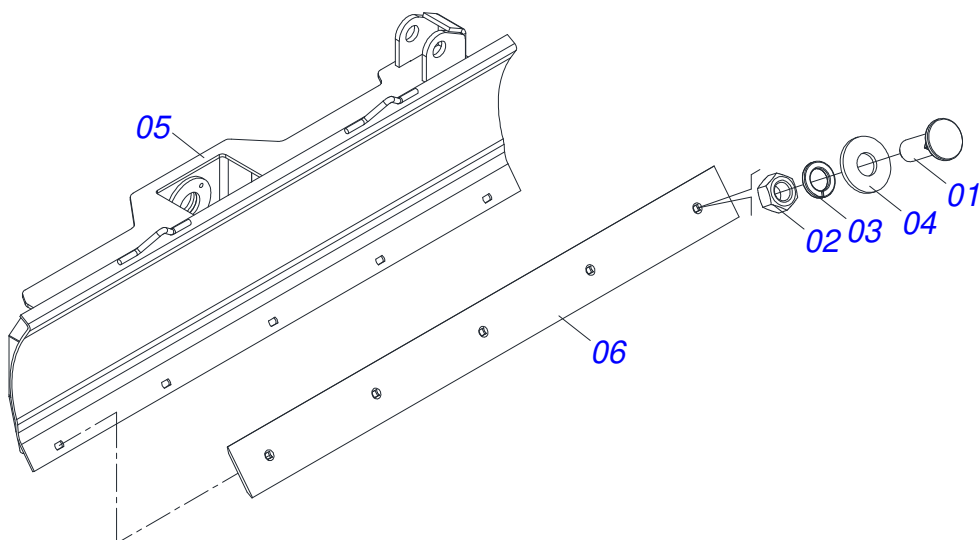

Artículo	Código	Descripción	Ver Pág.	QT
01	0503012956	TORNILLO 1/2" BSW X 1.1/2"		05
02	0503012682	TUERCA HEXAGONAL BSW 1/2"		05
03	0503011440	ARANDELA PRESION		05
04	0511017302	ARANDELA PLANA 13,50 X 32,50 X 3,0 ZN		05
05	0531066208	SOPORTE RASCADOR		01
06	0501311759	RASCADOR		01

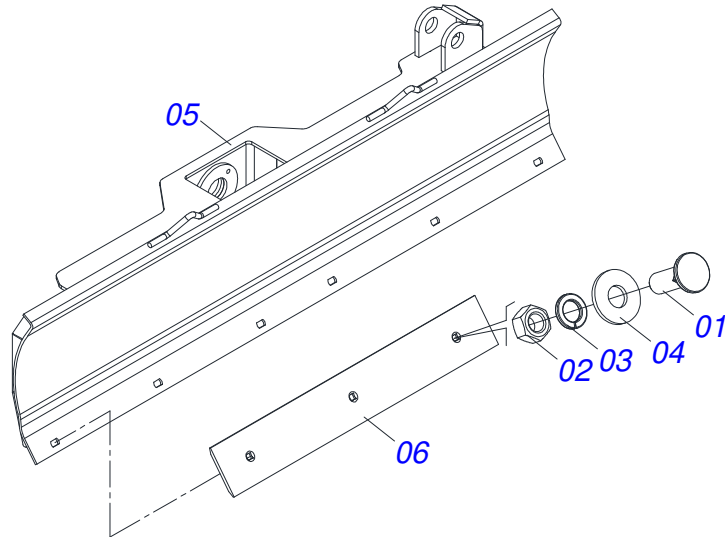

Artículo	Código	Descripción	Ver Pág.	QT
01	0503012956	TORNILLO 1/2" BSW X 1.1/2"		06
02	0503012682	TUERCA HEXAGONAL BSW 1/2"		06
03	0503011440	ARANDELA PRESION		06
04	0511017302	ARANDELA PLANA 13,50 X 32,50 X 3,0 ZN		06
05	0531066207	SOPORTE RASCADOR		01
06	0501311753	RASCADOR		02

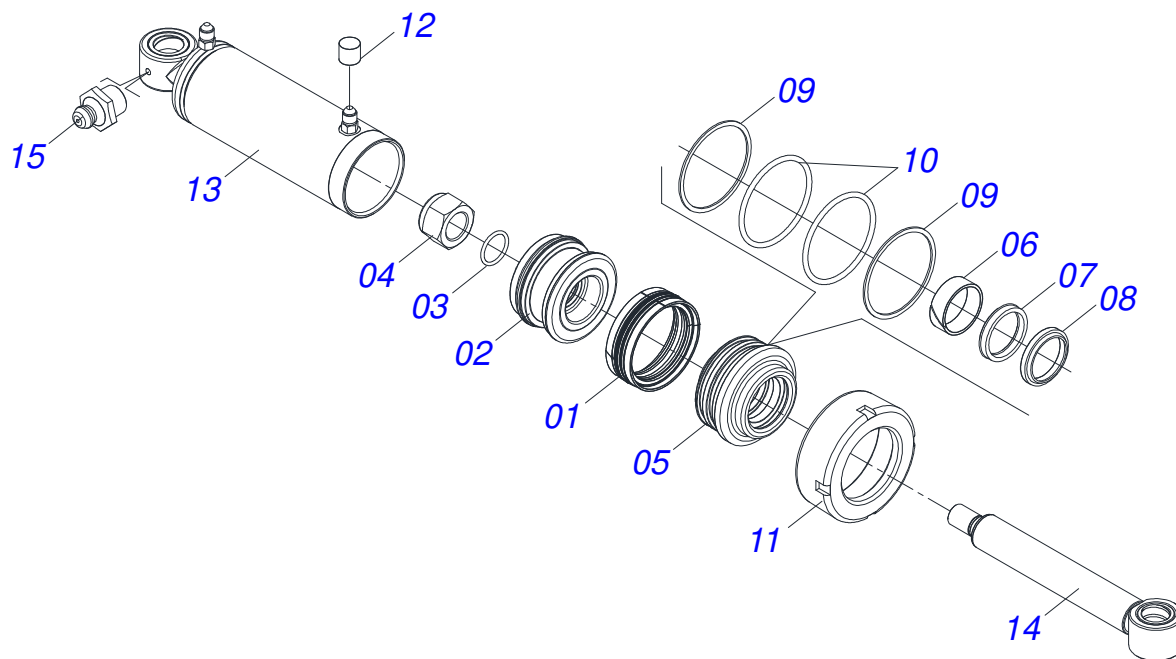

Artículo	Código	Descripción	Ver Pág.	QT
01	0503015633	SELLADO SELEMASTER		01
02	0502012842	EMBOLO 50,80 X 101,60		01
03	0503010345	ANILLO O'RING 2-218 N 3006-9B		01
04	0503010817	TUERCA 1.1/4		01
05	0581010678	SOPORTE ANILLOS 50,80 X 85,72		01
06	0503018025	ANILLO GUIA		01
07	0503018026	ANILLO 1870-2000-375 B		01
08	0503015636	RASCADOR DE CIERRE		01
09	0503011061	ANILLO BACK-UP 8-342		02
10	0503010338	ANILLO O'RING 2-342 N 3006-9B		02
11	0502012822	TAPA MOVIL 101,60		01
12	0503030385	PLUG CILINDRICO N-002		02
13	0531066236	CAMISA DE CILINDRO 101,6 X 377,5		01
14	0531066378	EXTENSOR DE CILINDRO 50,80 X 390,5		01
15	0503010002	GRASERA 1800		02

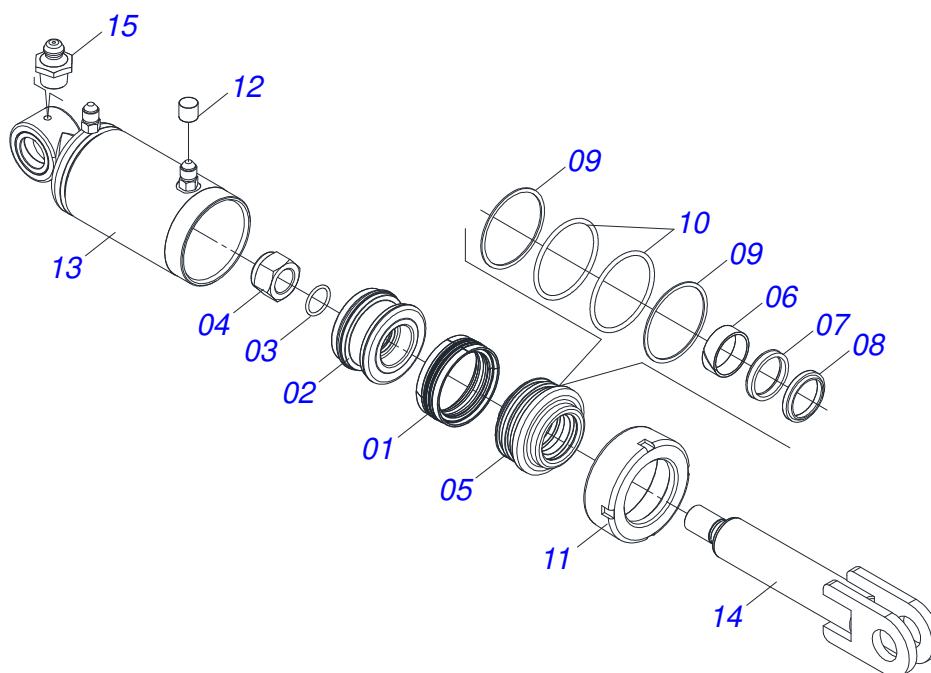

Artículo	Código	Descripción	Ver Pág.	QT
01	0503015633	SELLADO SELEMASTER		01
02	0502012842	EMBOLO 50,80 X 101,60		01
03	0503010345	ANILLO O'RING 2-218 N 3006-9B		01
04	0503010817	TUERCA 1.1/4		01
05	0581010678	SOPORTE ANILLOS 50,80 X 85,72		01
06	0503018025	ANILLO GUIA		01
07	0503018026	ANILLO 1870-2000-375 B		01
08	0503015636	RASCADOR DE CIERRE		01
09	0503011061	ANILLO BACK-UP 8-342		02
10	0503010338	ANILLO O'RING 2-342 N 3006-9B		02
11	0502012822	TAPA MOVIL 101,60		01
12	0503030385	PLUG CILINDRICO N-002		02
13	0531066375	CAMISA DE CILINDRO 101,6 X 274,5		01
14	0531065684	EXTENSOR DE CILINDRO 50,8 X 365		01
15	0503010002	GRASERA 1800		01

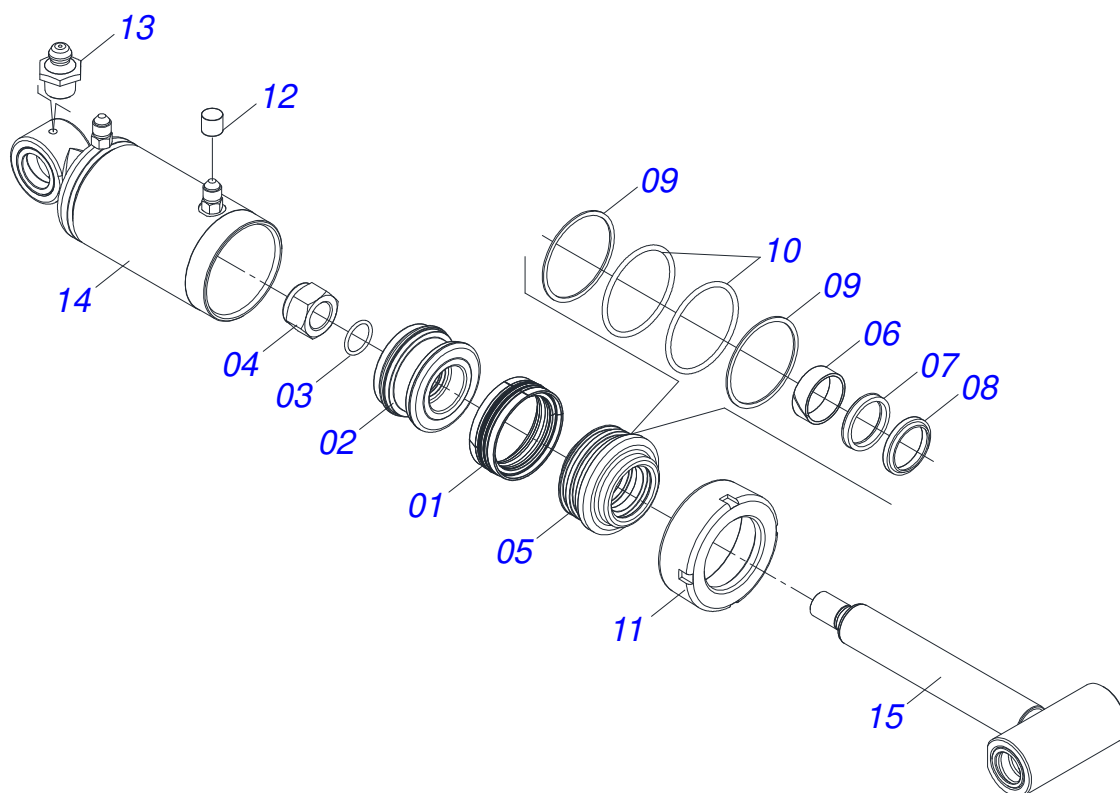

Artículo	Código	Descripción	Ver Pág.	QT
01	0503015633	SELLADO SELEMASTER		01
02	0502012842	EMBOLO 50,80 X 101,60		01
03	0503010345	ANILLO O'RING 2-218 N 3006-9B		01
04	0503010817	TUERCA 1.1/4		01
05	0581010678	SOPORTE ANILLOS 50,80 X 85,72		01
06	0503018025	ANILLO GUIA		01
07	0503018026	ANILLO 1870-2000-375 B		01
08	0503015636	RASCADOR DE CIERRE		01
09	0503011061	ANILLO BACK-UP 8-342		02
10	0503010338	ANILLO O'RING 2-342 N 3006-9B		02
11	0502012822	TAPA MOVIL 101,60		01
12	0503030385	PLUG CILINDRICO N-002		02
13	0503010002	GRASERA 1800		02
14	0531066374	CAMISA DE CILINDRO		01
15	0531065880	EXTENSOR DE CILINDRO 50,80 X 386		01

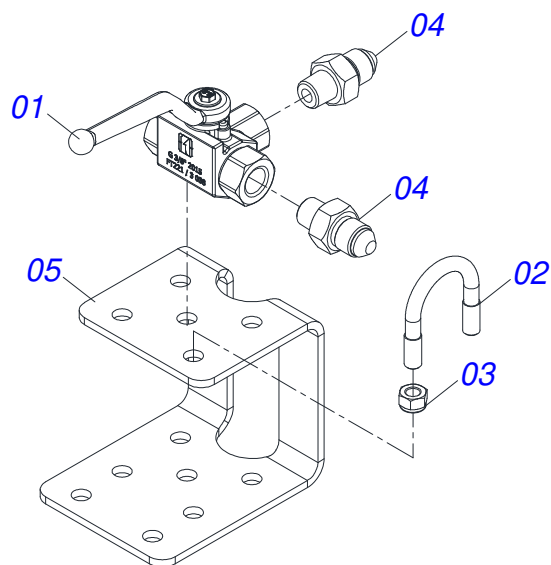

Artículo	Código	Descripción	Ver Pág.	QT
01	0503016612	VALVULA		02
02	0551019884	PERNO 45 X 50 X 3/8		04
03	0503013357	TUERCA 3/8 NC		08
04	0571013798	NIPLE		06
05	0501312186	SOPORTE DE REGISTRO		01

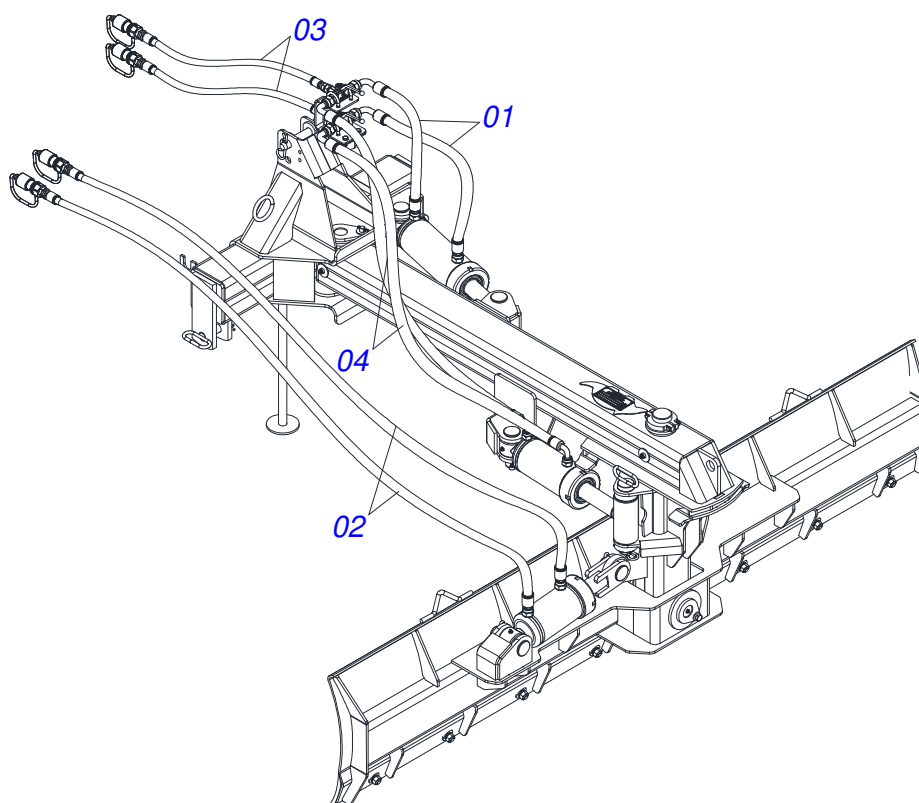

Artículo	Código	Descripción	Ver Pág.	QT
01	0501080124	MANGUERA 3/8 X 900 TR-TC		02
02	0501080528	MANGUERA 3/8 X 3700 TR-TM		02
03	0501080371	MANGUERA 3/8" X 1400 TR-TM		02
04	0501080514	MANGUERA 3/8 X 1700 TC-TC		02

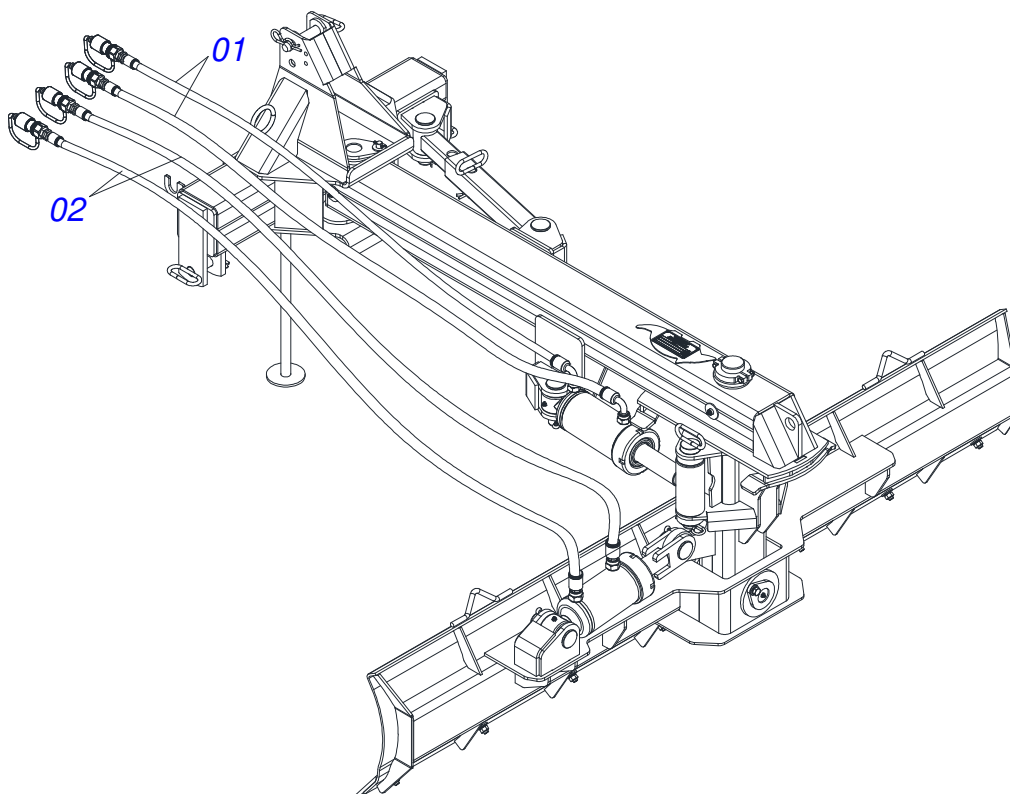

Artículo	Código	Descripción	Ver Pág.	QT
01	0501080553	MANGUERA 3/8" 3200 TC-TM		02
02	0501080528	MANGUERA 3/8 X 3700 TR-TM		02

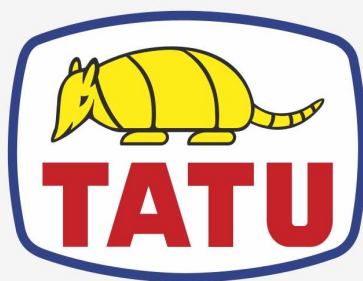

MARCHESAN

Publicaciones Técnicas | Elaboración y Revisión

LORENA ROCHA ALVES

www.marchesan.com.br

