

ROTARY CUTTERS

RCP2E 1500 CM

Code: 0501093455
Series: S-0222
Revision: 00
Date Revision: MARÇO/2023

PARTS CATALOGUE



MARCHESAN



PRODUCTS

Code	Description
0104030017	RCP2 E 1500 (CM) S-0222

ATTENTION: IMPORTANT

Marchesan S.A. reserves the right to improve and/or modify the technical features of its products, without obligation to do the same with those products already sold and without prior knowledge of the dealer or the customer. The photos are only illustrative.



MARCHESAN

INDEX

0909091145	FRAME ASSY	1
0531054480	SEMI MOUNTED FRAME	2
0531054492	SUPPORT 340 WITH ROCATOR/TRIMMER/ DEFLECTOR	3
0501046978	SPEED MULTIPLIER	4
0501043535	DOUBLE DISTRIBUTOR	5
0501047951	DRIVE SHAFT	6
0501043660	FRICION	7
0501047947	DRIVE SHAFT	8
0531054491	REAR LEFT SIDE CHAIN PROTECTION (545)	9
0531054490	RIGHT REAR SIDE CHAIN PROTECTION (545)	10
0531054489	REAR CHAIN PROTECTION (760)	11
0531054488	FRONT CHAIN PROTECTION (760)	12
0531054495	MANUAL CANISTER ASSY	13

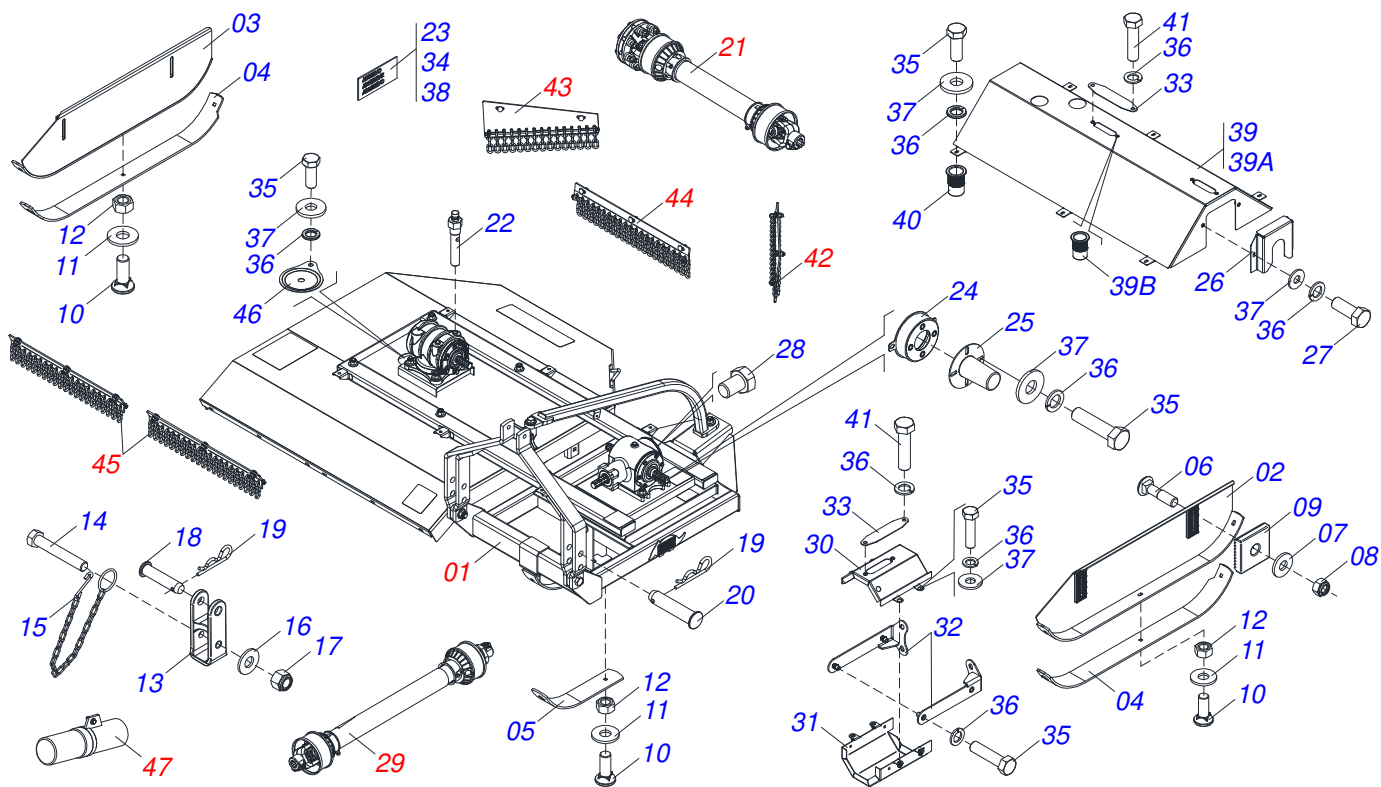

Item	Code	Description	See page	QT
01	0531054480	SEMI MOUNTED FRAME	2	01
02	0521066192	LEFT SKATE		01
03	0521066193	RIGHT SKATE		01
04	0531019433	SKID GUIDE		02
05	0521013465	SKID GUIDE		01
06	0501014177	5/8" X 2-1/2" BOLT		04
07	0501012140	FLAT WASHER		04
08	0503013389	5/8" SELF LOCKING NUT		04
09	0502010083	SQUARE WASHER		04
10	0503012956	1/2" X 1-1/2" BOLT		08
11	0511017302	FLAT WASHER 13,50 X 32,50 X 3,0 ZN		08
12	0503012682	1/2" BSW NUT		08
13	0502040922	DRAWBAR SUPPLEMENT		01
14	0501011545	3/4" X 6-1/2" BOLT		01
15	0503011981	17.7" CHAIN WITH HOOK/LINK		01
16	0501010104	45 X 20 X 4 FLAT WASHER		01
17	0503011075	3/4" UNC NUT		01
18	0521010578	COUPLING SHAFT		01
19	0503031035	HITCH PIN CLIP		03
20	0521010596	COUPLING SHAFT		02
21	0501047951	DRIVE SHAFT	6	01
22	0501110186	OIL SMALLER LEVEL INDICATOR		01
23	0503031127	ADHESIVE LABEL		01
24	0501110971	SHAFT PROTECTION FIXING SUPPORT WITH RIVET		01
25	0503034005	COVER PROTECTION FOR SHAFT		01
26	0501213221	MULTIPLIER PROTECTION COVER COMPLEMENT		01
27	0503010751	C3/8" X 1.1/4" HEX BOLT G.5		20
28	0503035742	VISOR LEVEL TIP IS 3/8 BUST		01
29	0501047947	DRIVE SHAFT	8	01
30	0501110998	CARDAN TOP PROTECTION COVER		01



Item	Code	Description	See page	QT
31	0501111144	BOTTOM PROTECTION COVER COUPLING WITH RIVET		01
32	0501110997	LARGER SUPPORT COVER PROTECTION		02
33	0581012546	LUBRICATION AXIS TRANSMISSION		03
34	0503034247	ADHESIVE LABEL POINT LUBRICATION		03
35	0503010237	3/8" X 1" BOLT		05
36	0503010025	3/8 SPRING WASHER		21
37	0501010984	10,50 X 27 X 3,00 FLAT WASHER		21
38	0503031087	ADHESIVE LABEL		01
39	0531054499	MULTIPLIER PROTECTION COVER WITH RIVET		01
39A	0531063714	COVER PROTECTION MULTIPLIER		01
39B	0503019416	RIVET SCREW THREAD INTERNAL		06
40	0503019416	RIVET SCREW THREAD INTERNAL		07
41	0503010256	3/8" X 3/4" BOLT		06
42	0531054491	REAR LEFT SIDE CHAIN PROTECTION (545)	9	01
43	0531054490	RIGHT REAR SIDE CHAIN PROTECTION (545)	10	01
44	0531054489	REAR CHAIN PROTECTION (760)	11	01
45	0531054488	FRONT CHAIN PROTECTION (760)	12	02
46	0591012025	ACCESS COVER		01
47	0531054495	MANUAL CANISTER ASSY	13	01

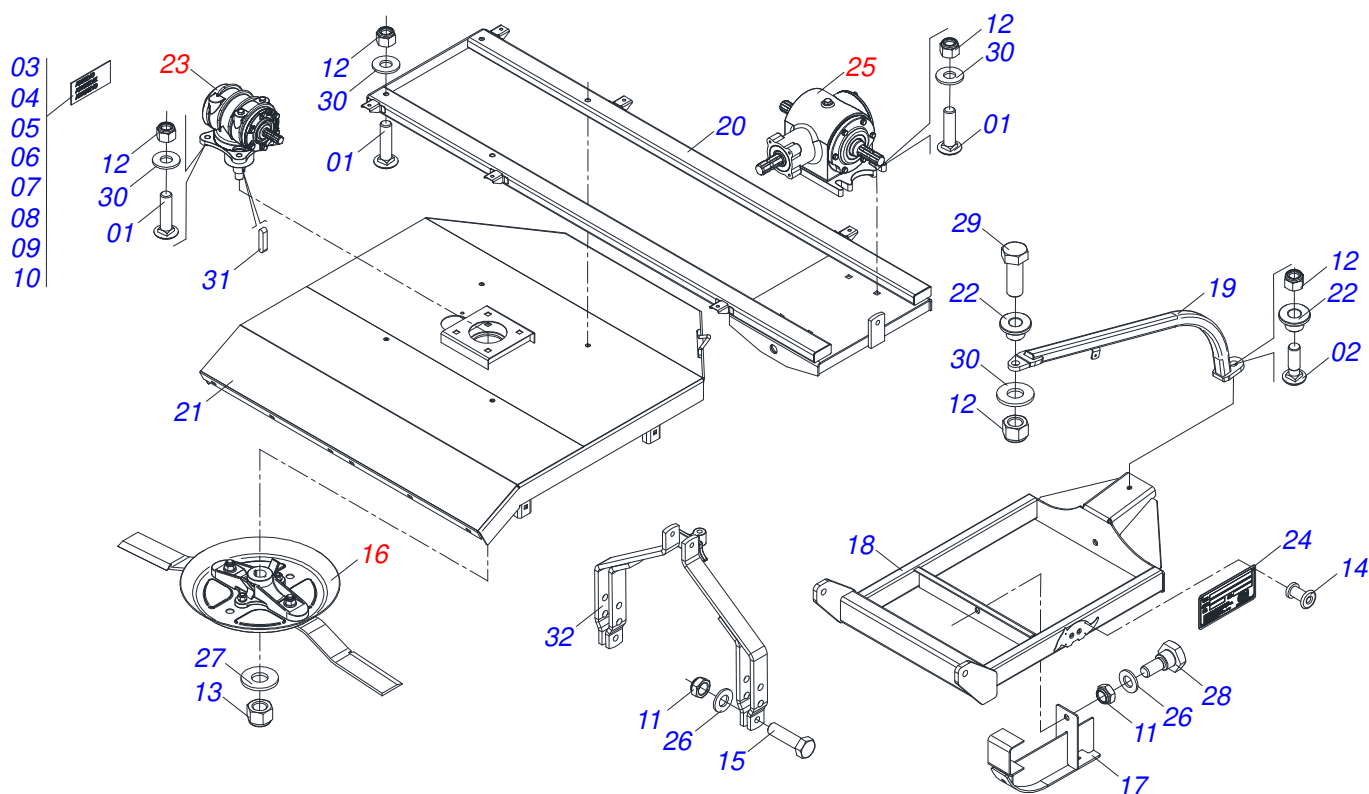

Item	Code	Description	See page	QT
01	0503017867	SCREW 3/4 UNC X 4.1/2 CAPQ G.7 ZN		12
02	0503014249	3/4" X 2-1/2" BOLT		01
03	0503035635	ADHESIVE LABEL RCP2 E 1500		01
04	0503034333	ADHESIVE LABEL		01
05	0503032949	ADHESIVE LABEL		01
06	0503032534	ADHESIVE LABEL		01
07	0503031931	ADHESIVE LABEL		01
08	0503031930	ADHESIVE LABEL		01
09	0503031428	READ MANUAL DECAL		01
10	0503031427	ADHESIVE LABEL		01
11	0503014182	SELF-ADJUSTING NUT		04
12	0503011075	3/4" UNC NUT		14
13	0503010044	1-1/4" SELF LOCKING NUT		01
14	0503010001	3.2 X 5.5 RIVET		04
15	0501010171	BOLT 1 UNC X 3.1/2 C S G.5		02
16	0531054492	SUPPORT 340 WITH ROCATOR/TRIMMER/ 3 DEFLECTOR		01
17	0531063704	DRAWBAR SUPPORT SKID		01
18	0531063699	DRAWBAR SUPPORT		01
19	0531063703	FRENCH HAND (1137)		01
20	0531063698	FRAME SUPPORT		01
21	0531063694	FRAME		01
22	0591014147	FRENCH HAND GUIDE GLOVE		02
23	0501046978	SPEED MULTIPLIER	4	01
24	0503034003	SERIAL NUMBER TAG 61 X 118		01
25	0501043535	DOUBLE DISTRIBUTOR	5	01
26	0511015994	FLAT WASHER		04
27	0501017779	32 X 60 X 4.75 FLAT WASHER		01
28	0501014685	PIVOT SHAFT		02
29	0501010216	3/4 UNC X 4.1/2 C S G.5 ZN BOLT		01
30	0501010322	FLAT WASHER		13
31	0501010536	KEYWAY SQUARE		02



**RCP2E 1500 CM
SEMI MOUNTED FRAME**

Page 2
0531054480

Item	Code	Description	See page	QT
32	0501067832	DRAWBAR		01

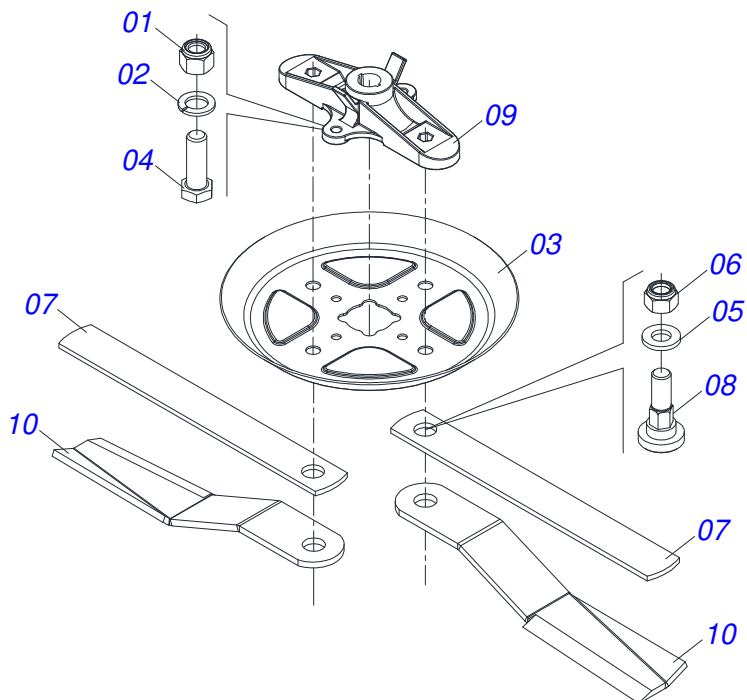

Item	Code	Description	See page	QT
01	0503010014	3/4" HEX NUT		02
02	0503011442	3/4" SPRING WASHER		02
03	0591010130	SUPPORT DEFLECTOR (340)		01
04	0501010098	3/4" UNC BOLT		02
05	0501016545	FLAT WASHER		02
06	0503010063	1" SELF-ALIGNING NUT		02
07	0531015055	620 FOLLOWER		02
08	0541014286	FASTERNER ROCADORES		02
09	0502012275	ROTARY SUPPORT 340		01
10	0622340051	24.5" X 3.94" X 0.5" ROTARY CUTTER RIGHT		02

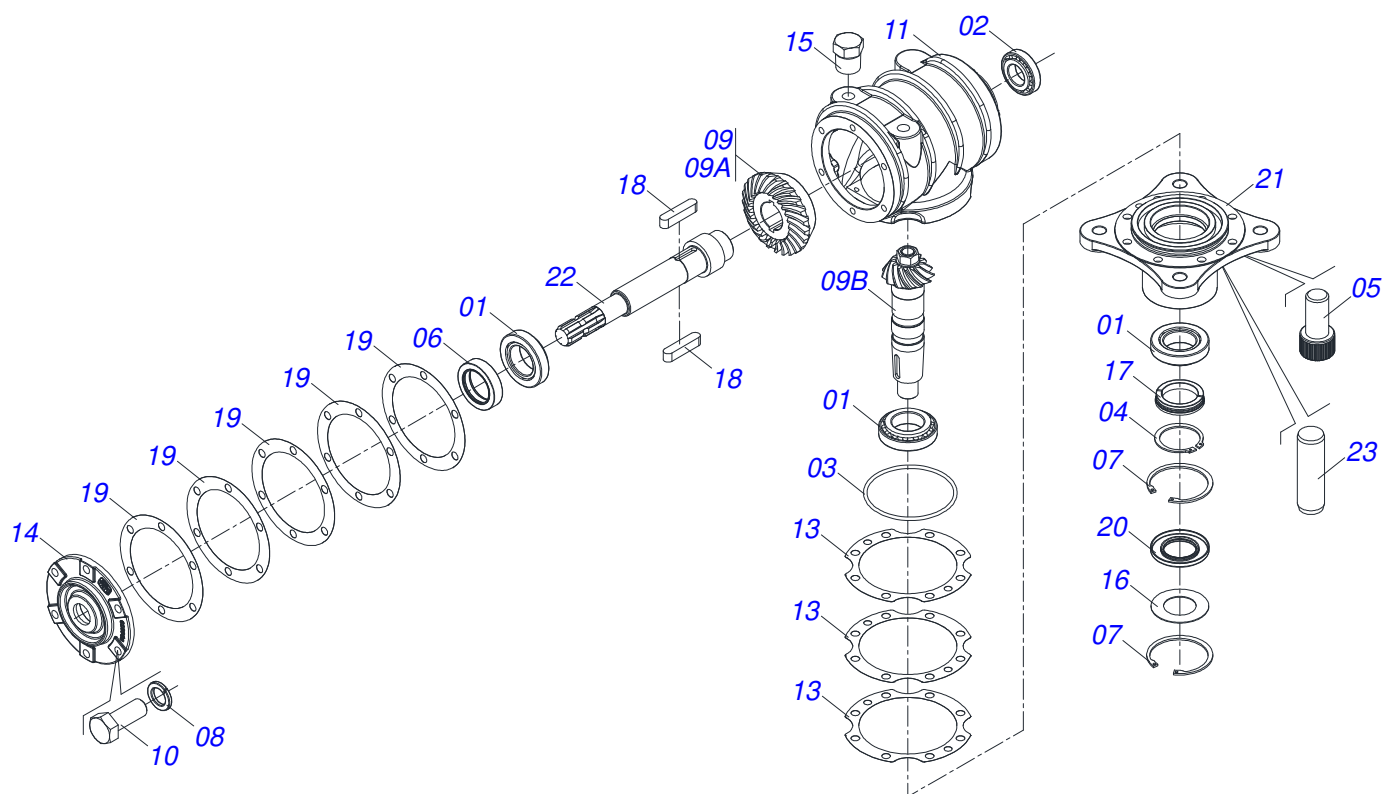

Item	Code	Description	See page	QT
01	0503010006	32210 ROLLER BEARING		03
02	0503010037	30207 ROLLER BEARING		01
03	0503010286	2-355 N 3006-9B O'RING		01
04	0503010396	501060 CLAMPING RING (FOR AXLE)		01
05	0503010562	1/2" X 1" BOLT		08
06	0503011171	00912-BRG SEAL		01
07	0503011190	SEAL RING		02
08	0503011440	SPRING WASHER		06
09	0503060211	CROWN PINION SET		01
09A	0503050069	25Z CONICAL GEAR		01
09B	0503061048	PINION		01
10	0503010395	1/2" X 1-1/4" BOLT		06
11	0502010983	RIGHT MULTIPLIER BOX		01
12	3402301247	MINERAL OIL GREASE		2,5Lts
13	0503030785	7.9" X 5.9" X 0.008" JOINT		03
14	0502010986	SMALLER COVER		01
15	0503031604	1/2" BSP PLUG		02
16	0521018064	FLAT WASHER		01
17	0511010142	LOCK RING		01
18	0501010536	KEYWAY SQUARE		02
19	0503030783	7.1" X 5.3" X 0.008" JOINT		05
20	0503011047	5089 SEAL		01
21	0502011393	LOWER HUB		01
22	0503050068	UPPER AXLE		01
23	0503017877	PIN GUIDE		02

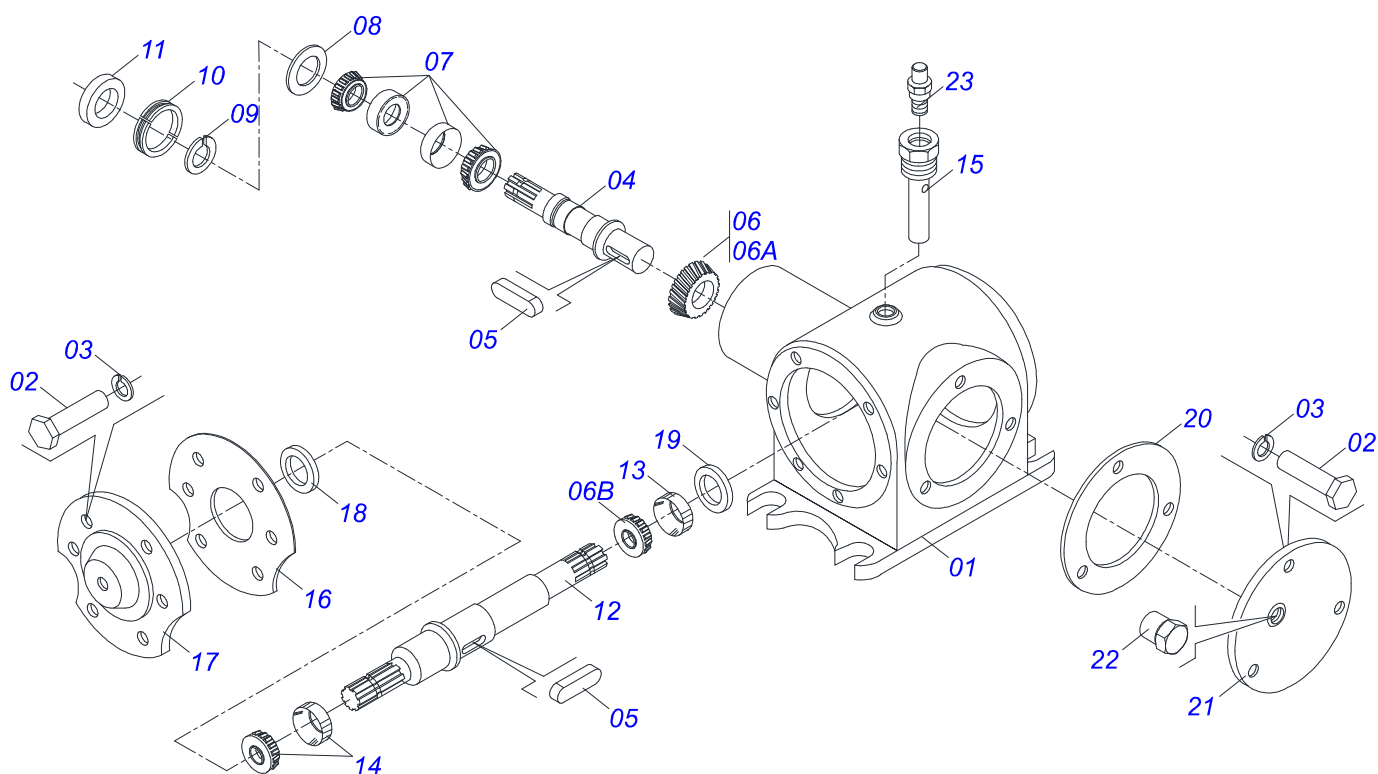

Item	Code	Description	See page
01	0502010801	DOUBLE DISTRIBUTOR HUB	01
02	0503010751	C3/8" X 1.1/4" HEX BOLT G.5	09
03	0503011443	3/8" SPRING WASHER	09
04	0503030111	SMALLER AXLE	01
05	0501012993	0.4" X 1.1"KEYWAY SQUARE	04
06	0503060249	CONICAL GEAR SET FOR DOUBLE DISTRIBUTOR	01
06A	0503030113	15Z RIGHT CONICAL GEAR	01
06B	0503031811	15Z LEFT CONICAL GEAR	01
07	0503010102	25577/25523 ROLLER BEARING	02
08	0501010237	FLAT WASHER	01
09	0503010210	LOCK WASHER	01
10	0503010211	KM- 8 LOCKNUT	01
11	0503010079	5042 SEAL	01
12	0511010103	LARGER AXLE	01
13	0503010312	6207 BALL BEARING	01
14	0503010031	368A/362A ROLLER BEARING	01
15	0521014311	DOUBLE DISTRIBUTOR BREATHER BODY	01
16	0503030228	7.1" X 5.3" X 0.008" JOINT	02
17	0502020250	FRONT COVER	01
18	0503010082	00274-BG SEAL	01
19	0503010079	5042 SEAL	01
20	0503030341	6.4" X 0.008" JOINT	04
21	0502020160	COVER WITH DOUBLE DISTRIBUTOR	01
22	0503031604	1/2" BSP PLUG	01
23	0503010325	VCA-118 VALVE	01

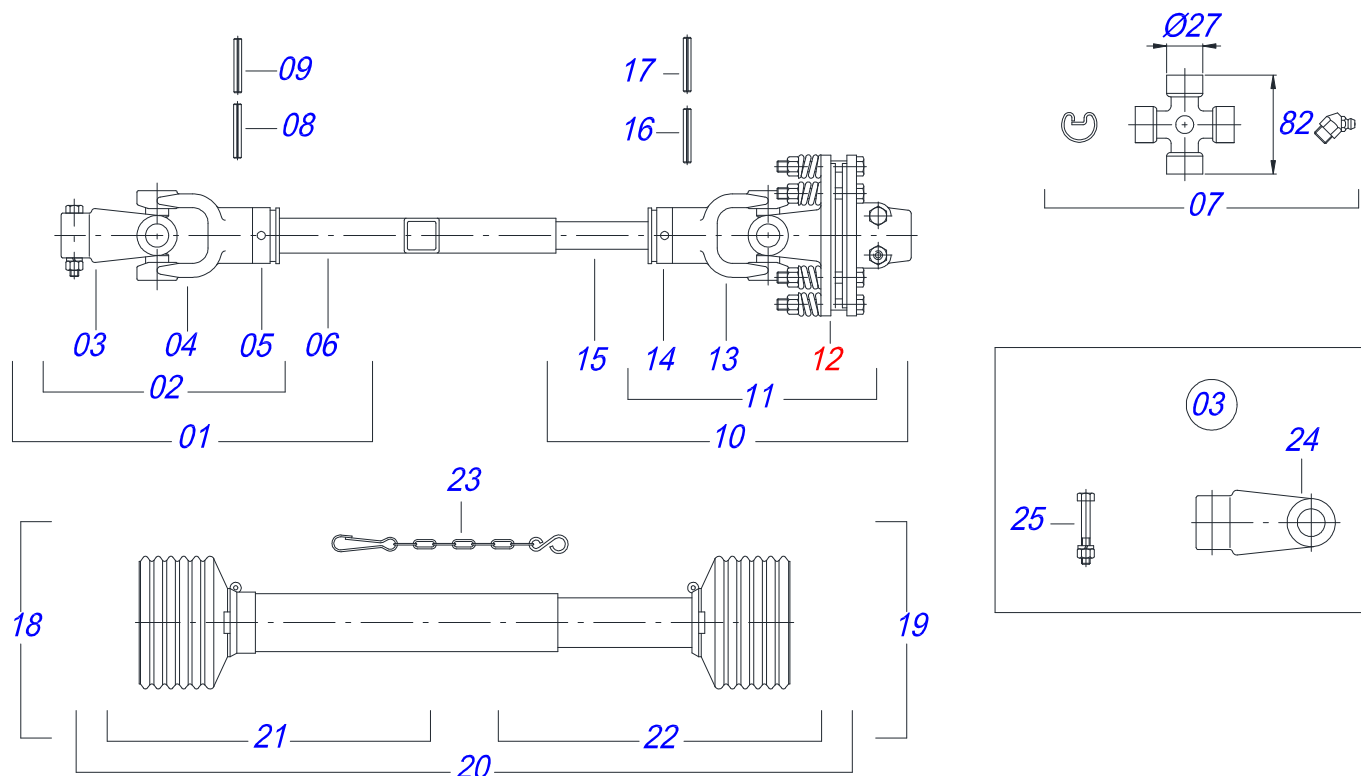

Item	Code	Description	See page	QT
01	0501050861	UNIVERSAL JOINT WITH SLEEVE		01
02	0501050465	UNIVERSAL JOINT		01
03	0501052526	T8-40 TERMINAL WITH SCREW		01
04	0502010565	2-40 TERMINAL WITH SH 1.5"/1.5"		01
05	0503012069	ADAPTER FOR BUSHING PROTECT		01
06	0521013800	16" X 1.4" SQUARE SLEEVE		01
07	0503010836	CARDAN CROSSPIECE		02
08	0503011069	0.4" X 2.8" SPRING PIN		01
09	0503010510	0.2" X 2.6" SPRING PIN		01
10	0501050862	UNIVERSAL JOINT WITH CROSS AND AXLE		01
11	0501050466	UNIVERSAL JOINT WITH CROSSPIECE		01
12	0501043660	FRICITION	7	01
13	0502010566	3-40 TERMINAL WITH SH 1.2"/1.2"		01
14	0503012070	ADAPTER FOR AXLE PROTECTION		01
15	0521013801	1.2" X 15.7" SQUARE SHAFT		01
16	0503010361	SPRING PIN		01
17	0503010756	0.2" X 2.4" SPRING PIN		01
18	0501051703	UNIVERSAL JOINT WITH PROTECTION SLEEVE		01
19	0501051704	UNIVERSAL JOINT WITH PROTECTION AXLE		01
20	0503012080	PROTECTION ASSY		01
21	0503012081	PLASTIC PROTECTION FOR JOINT/SLEEVE		01
22	0503012082	PROTECTION FOR UNIV JOINT AND AXLE		01
23	0503012023	CHAIN FOR PROTECTION		02
24	0502010876	8-40 STRIATED 1.3/8 TERMINAL		01
25	0501047756	1/2" X 3" SET PARTS		01

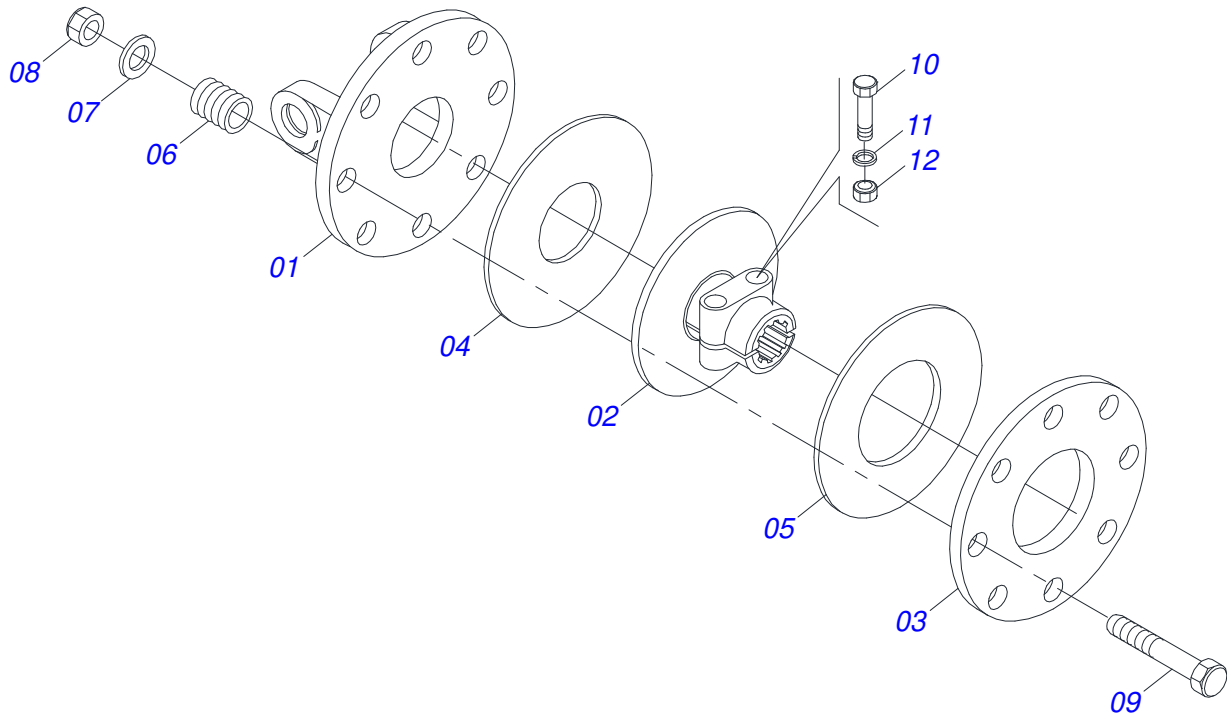

Item	Code	Description	See page	QT
01	0503011869	CENTRAL FLANGE		01
02	0503031478	OUTER FRICTION DISC		01
03	0503011870	REAR FLANGE		01
04	0503031474	INNER FRICTION DISC		01
05	0503011868	FRONT FLANGE		01
06	0503010752	1/2" X 3.1/2" BOLT		08
07	0503030630	1.02"X1.3"X0.2" COMPRESSION SPRING		08
08	0511017302	FLAT WASHER 13,50 X 32,50 X 3,0 ZN		08
09	0503011336	1/2" HEX SELF ADJUSTING NUT		08
10	0503010741	1/2" X 2-3/4" BOLT		02
11	0503010019	1/2" SPRING WASHER		02
12	0503010060	1/2 UNC G.5 ZN HEX NUT		02

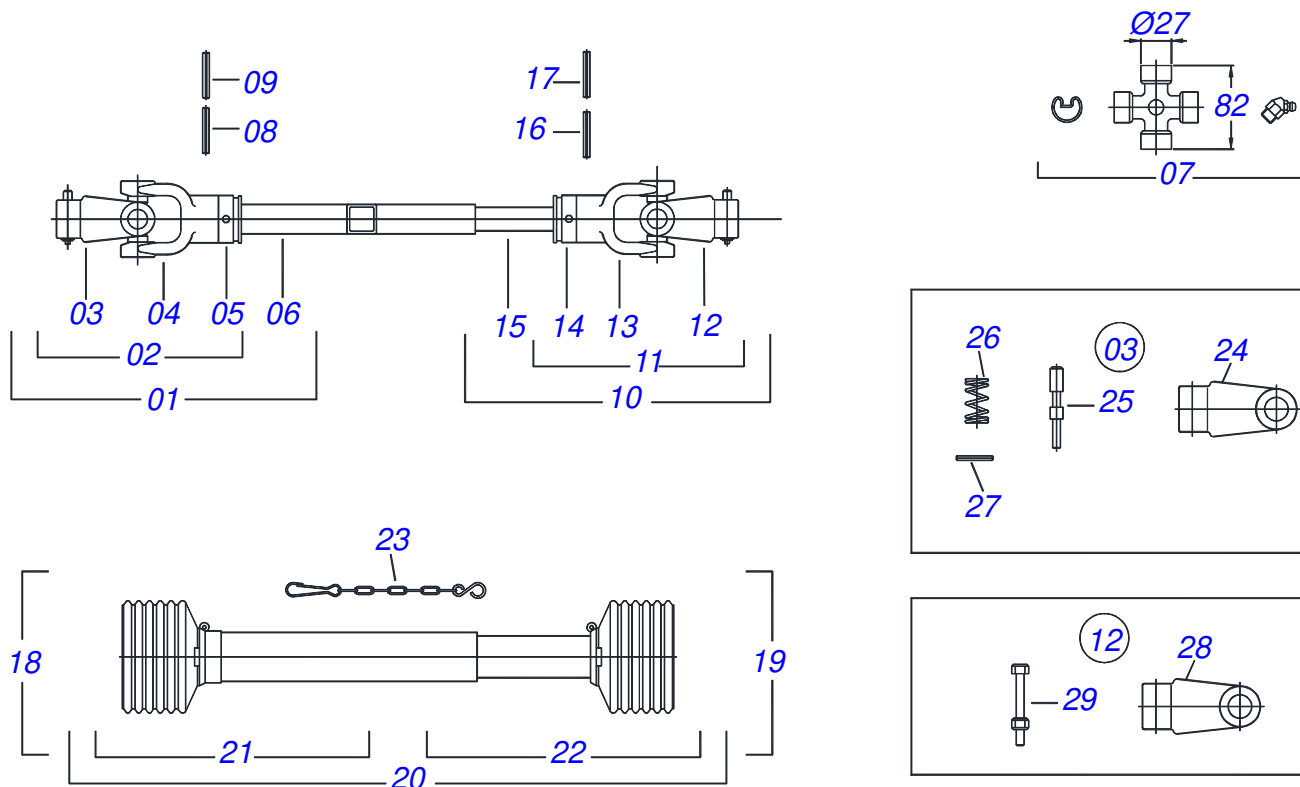

Item	Code	Description	See page
01	0501050271	UNIVERSAL JOINT WITH SLEEVE	01
02	0501050265	UNIVERSAL JOINT	01
03	0501050333	1-40 TERMINAL WITH HITCH	01
04	0502010565	2-40 TERMINAL WITH SH 1.5"/1.5"	01
05	0503012069	ADAPTER FOR BUSHING PROTECT	01
06	0501017429	31" X 1.5" SQUARE SLEEVE	01
07	0503010836	CARDAN CROSSPIECE	01
08	0503011069	0.4" X 2.8" SPRING PIN	01
09	0503010510	0.2" X 2.6" SPRING PIN	01
10	0501050866	UNIVERSAL JOINT WITH SHAFT	01
11	0501050449	UNIVERSAL JOINT	01
12	0501052526	T8-40 TERMINAL WITH SCREW	01
13	0502010566	3-40 TERMINAL WITH SH 1.2"/1.2"	01
14	0503012070	ADAPTER FOR AXLE PROTECTION	01
15	0501017425	1.2" X 31.5" SQUARE SHAFT	01
16	0503010361	SPRING PIN	01
17	0503010756	0.2" X 2.4" SPRING PIN	01
18	0501051696	UNIVERSAL JOINT WITH SLEEVE PROTECTION	01
19	0501051697	UNIVERSAL JOINT WITH AXLE PROTECTION	01
20	0503012071	PROTECTION ASSY	01
21	0503012072	PROTECTION FOR UNIV JOINT AND SLEEV	01
22	0503012073	PLASTIC PROTECTION FOR AXLE JOINT	01
23	0503012023	CHAIN FOR PROTECTION	02
24	0502010563	1-40 STRIATED 1.3/8" TERMINAL	01
25	0521010638	13,70 X 78 HITCH PIN	01
26	0503030518	0.5"X1.0"X 0.1" COMPRESSION SPRING	01
27	0503010838	0.1" X 0.8" SPRING PIN	01
28	0502010876	8-40 STRIATED 1.3/8 TERMINAL	01
29	0501047756	1/2" X 3" SET PARTS	01

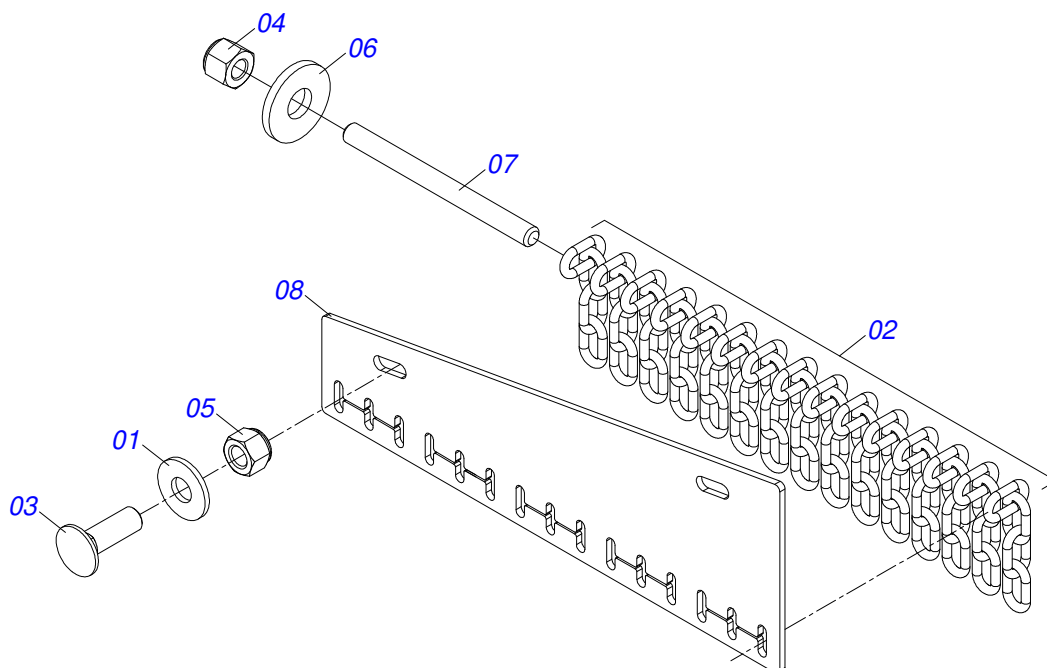

Item	Code	Description	See page	QT
01	0511017302	FLAT WASHER 13,50 X 32,50 X 3,0 ZN		02
02	0511011774	8,00 CHAIN 4 LINK		15
03	0503014378	1/2" X 1-1/2" BOLT		02
04	0503013759	NUT		02
05	0503010589	1/2" UNC SELF ADJUSTING NUT		02
06	0501010984	10,50 X 27 X 3,00 FLAT WASHER		02
07	0501213189	CHAIN PROTECTION ROD		01
08	0501213185	REAR SIDE CHAIN PROTECTION BODY		01

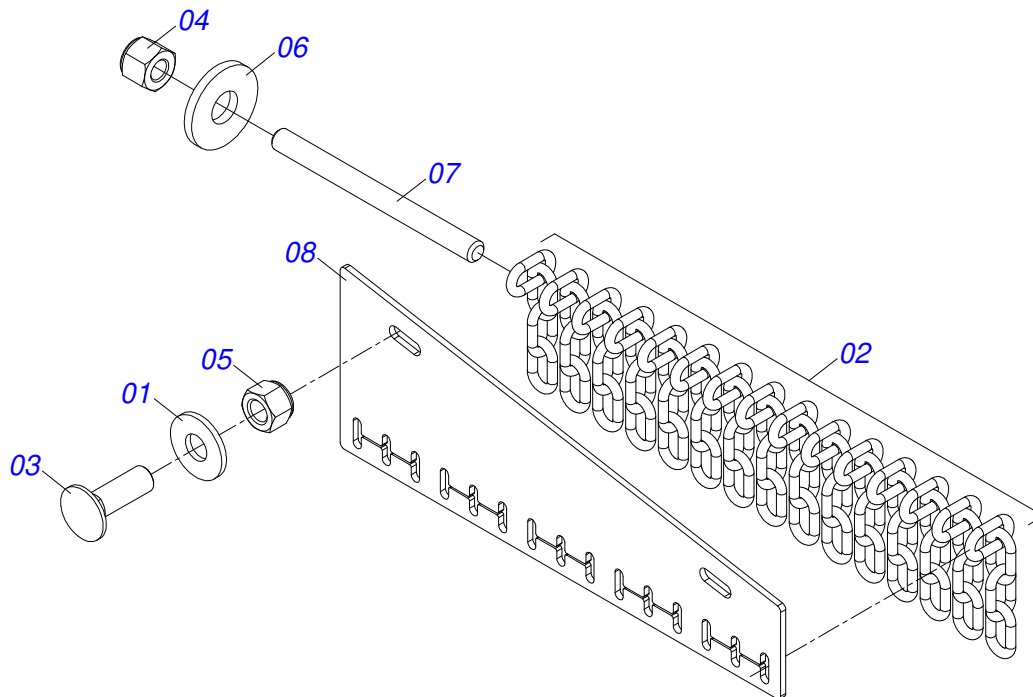

Item	Code	Description	See page	QT
01	0511017302	FLAT WASHER 13,50 X 32,50 X 3,0 ZN		02
02	0511011774	8,00 CHAIN 4 LINK		15
03	0503014378	1/2" X 1-1/2" BOLT		02
04	0503013759	NUT		02
05	0503010589	1/2" UNC SELF ADJUSTING NUT		02
06	0501010984	10,50 X 27 X 3,00 FLAT WASHER		02
07	0501213189	CHAIN PROTECTION ROD		01
08	0501213185	REAR SIDE CHAIN PROTECTION BODY		01

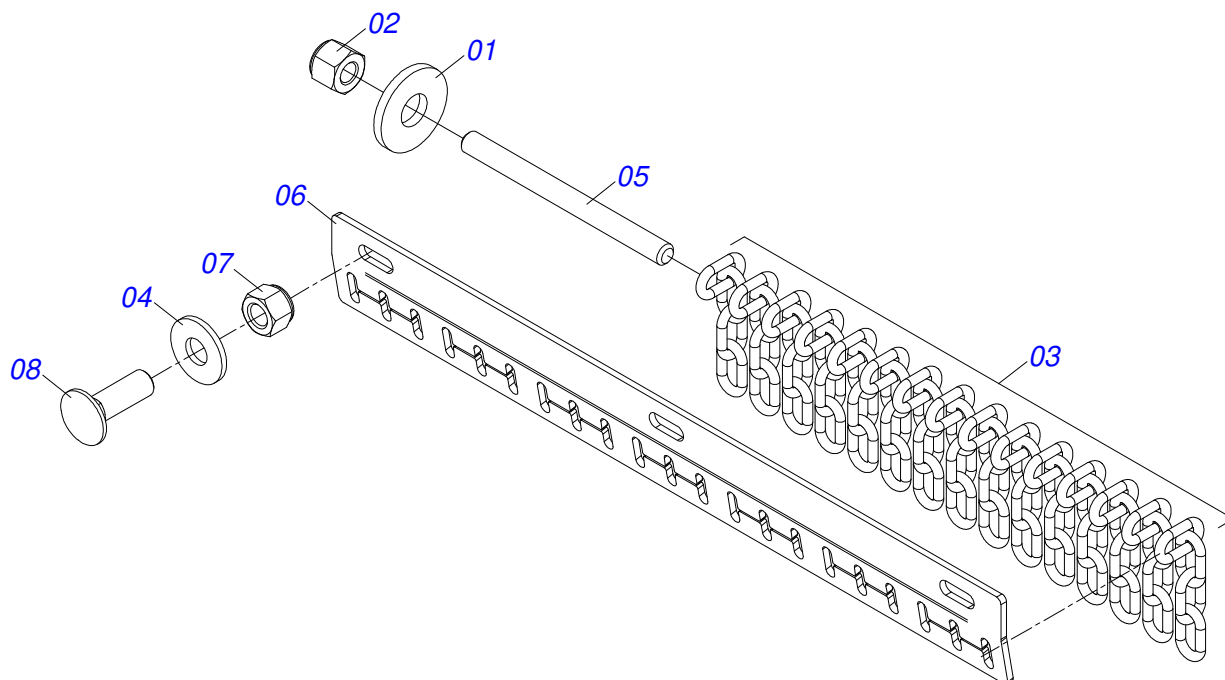

Item	Code	Description	See page	QT
01	0501010984	10,50 X 27 X 3,00 FLAT WASHER		02
02	0503013759	NUT		02
03	0511011774	8,00 CHAIN 4 LINK		21
04	0511017302	FLAT WASHER 13,50 X 32,50 X 3,0 ZN		03
05	0591014181	CURRENT PROTECTION BAR		01
06	0501213184	REAR CHAIN PROTECTION BODY		01
07	0503010589	1/2" UNC SELF ADJUSTING NUT		03
08	0503014378	1/2" X 1-1/2" BOLT		03

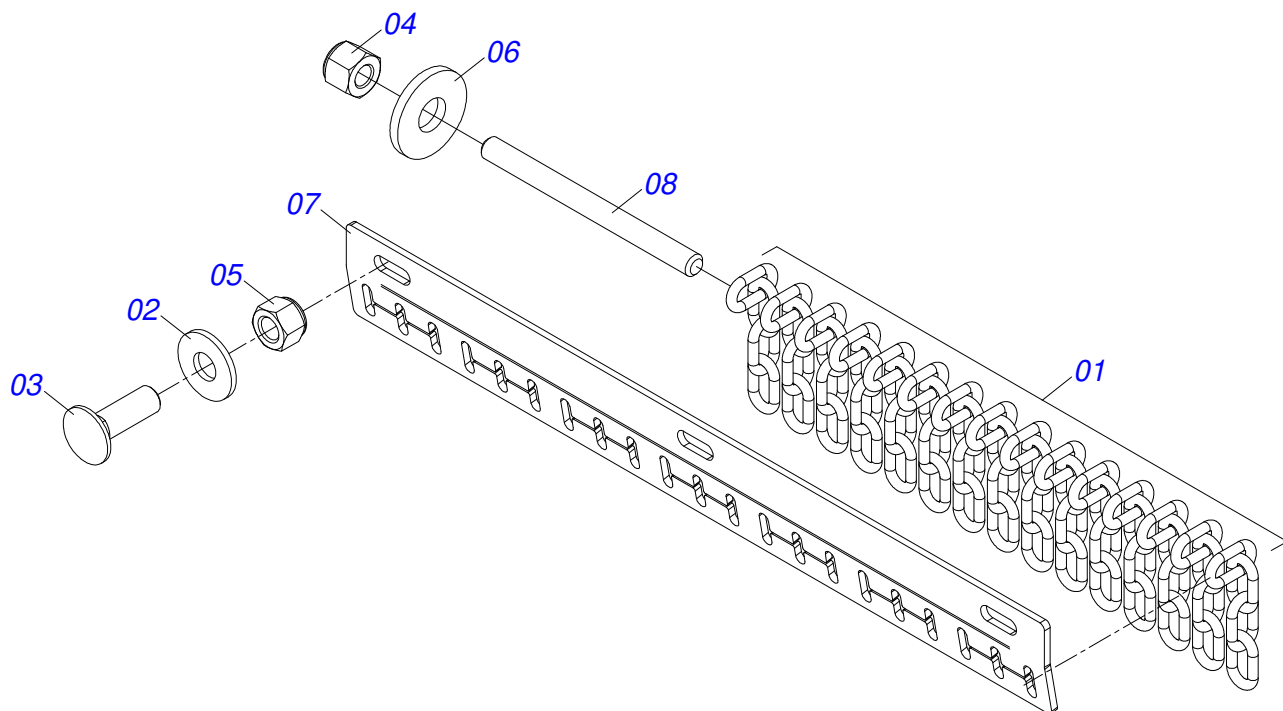

Item	Code	Description	See page	QT
01	0511011774	8,00 CHAIN 4 LINK		21
02	0511017302	FLAT WASHER 13,50 X 32,50 X 3,0 ZN		03
03	0503014378	1/2" X 1-1/2" BOLT		03
04	0503013759	NUT		02
05	0503010589	1/2" UNC SELF ADJUSTING NUT		03
06	0501010984	10,50 X 27 X 3,00 FLAT WASHER		02
07	0501213183	FRONT CHAIN PROTECTION BODY		01
08	0591014181	CURRENT PROTECTION BAR		01

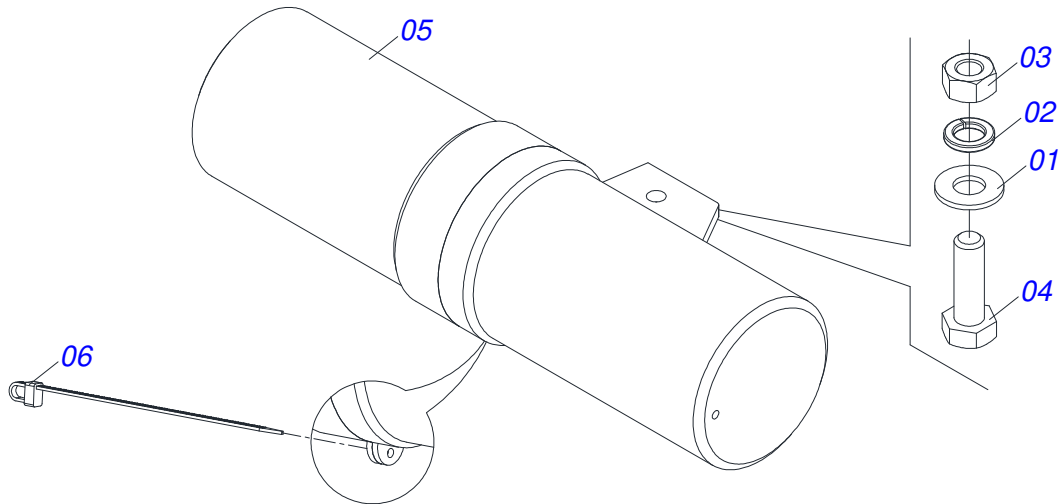

Item	Code	Description	See page	QT
01	0501010694	FLAT WASHER		01
02	0503010179	LOCK WASHER 5/16 ZN 1K01528		01
03	0503010337	5/16" NUT		01
04	0503010363	BOLT 5/16 UNC X 1 C S G.2 ZN		01
05	0503060100	INSTRUCTIONS MANUAL CANISTER		01
06	0503010267	NYLON CLAMP		01



MARCHESAN

Technical Publications | Elaboration and Revision

LUIZ CANDIDO

www.marchesan.com.br

