

HINGE TYPE OFFSET DISK HARROW

**GNCRP 64/68/72D - 1.1/2" AXLE - DOUBLE
WHEELED**

GNCRP 64/68/72D - EIXO 1.1/2" - RODADO DUPLO

Code: 0501093345

Series: S-0722

Revision: 00

Revision Date: JULY/2022

PARTS CATALOGUE



MARCHESAN



PRODUCTS

Code	Working Width	Description
0102520089		GNCRP 64 X 22 X 6,00 DL DMO E 1.1/2 LP RD S-0722
0102520091		GNCRP 64 X 22 X 6,00 DR DMO E 1.1/2 LP RD S-0722
0102520090		GNCRP 64 X 22 X 6,00 MT DMO E 1.1/2 LP RD S-0722
0102520088		GNCRP 64 X 24 X 6,00 DL DMO E 1.1/2 LP RD S-0722
0102520086		GNCRP 64 X 24 X 6,00 DR DMO E 1.1/2 LP RD S-0722
0102520087		GNCRP 64 X 24 X 6,00 MT DMO E 1.1/2 LP RD S-0722
0102520095		GNCRP 68 X 22 X 6,00 DL DMO E 1.1/2 LP RD S-0722
0102520097		GNCRP 68 X 22 X 6,00 DR DMO E 1.1/2 LP RD S-0722
0102520096		GNCRP 68 X 22 X 6,00 MT DMO E 1.1/2 LP RD S-0722
0102520093		GNCRP 68 X 24 X 6,00 DL DMO E 1.1/2 LP RD S-0722
0102520092		GNCRP 68 X 24 X 6,00 DR DMO E 1.1/2 LP RD S-0722
0102520094		GNCRP 68 X 24 X 6,00 MT DMO E 1.1/2 LP RD S-0722
0102520102		GNCRP 72 X 22 X 6,00 DL DMO E 1.1/2 LP RD S-0722
0102520101		GNCRP 72 X 22 X 6,00 DR DMO E 1.1/2 LP RD S-0722
0102520103		GNCRP 72 X 22 X 6,00 MT DMO E 1.1/2 LP RD S-0722
0102520100		GNCRP 72 X 24 X 6,00 DL DMO E 1.1/2 LP RD S-0722
0102520098		GNCRP 72 X 24 X 6,00 DR DMO E 1.1/2 LP RD S-0722
0102520099		GNCRP 72 X 24 X 6,00 MT DMO E 1.1/2 LP RD S-0722

ATTENTION: IMPORTANT

Marchesan S.A. reserves the right to improve and/or modify the technical features of its products, without obligation to do the same with those products already sold and without prior knowledge of the dealer or the customer. The photos are only illustrative.



MARCHESAN

INDEX

0909096429	ASSY FRAME - 64/68/72D	1
0531042994	DRAWBAR ASSY	2
0503060213	WHEEL WITH TIRE 35.4" X 0.80" / 14 CANVAS	3
0511058405	HYDRAULIC CYLINDER 50,80 X 101,60 X 561 X 252	4
0511059728	FRONT CLEANING ASSEMBLY	5
0511059729	REAR CLEANING ASSEMBLY	6
0501040257	3/4" X 38" HOSE SUPPORT ASSY	7
0521042030	WHEEL WITHOUT TIRE S-0514	8
0531055421	MANUAL CANISTER ASSY	9
0511048088	DRAWBAR JACK	10
0909096430	HYDRAULIC CIRCUIT	11
0501053834	MALE QUICK COUPLER	12
0909096431	64/68/72D - FRONT AND REAR DISC SECTION	13
0531042480	196 X 1.1/2 DMO AGRICULTURAL BEARING WITH PROTECTION SUPPORT	14
0531055221	196 X 1.1/2 IMP DMO AGRICULTURAL BEARING	15

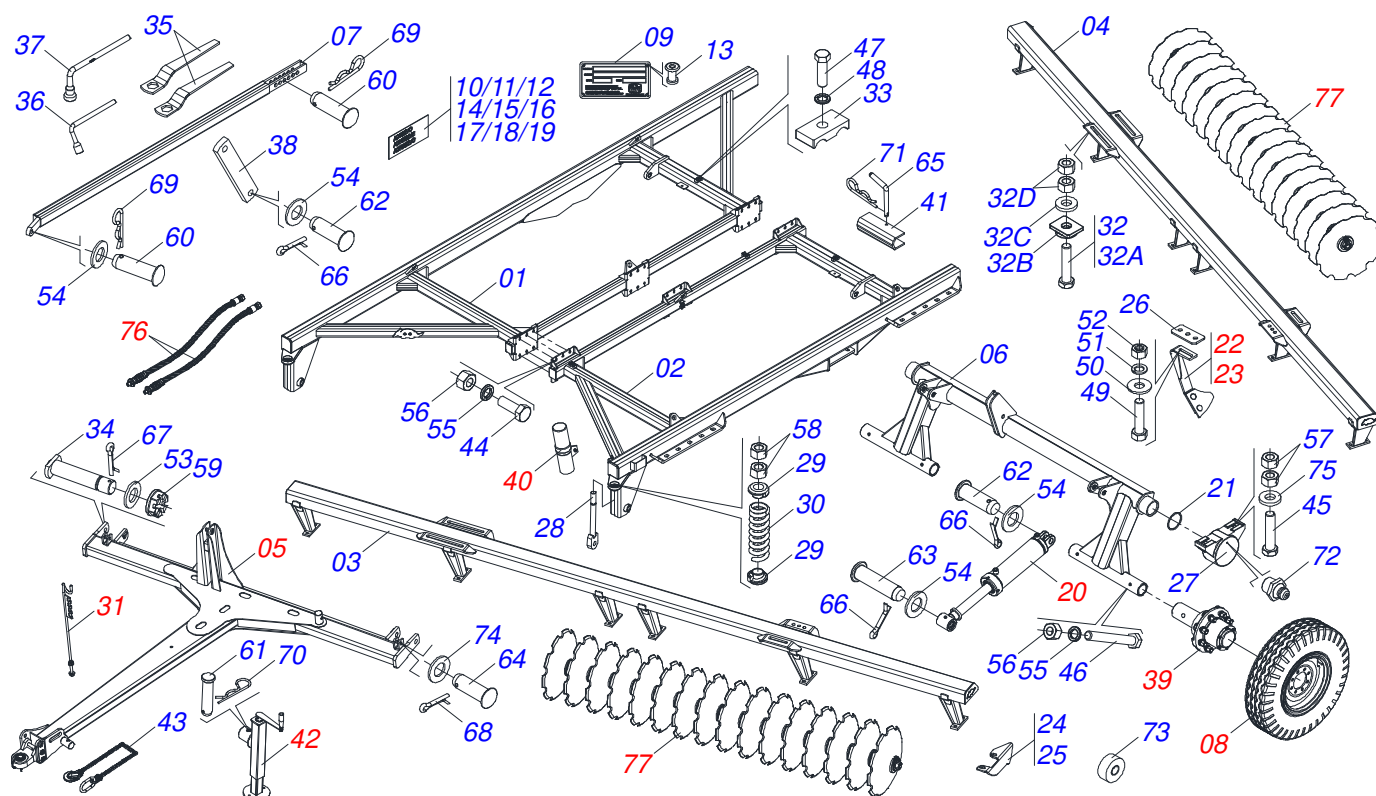

Item	Code	Description	See page	064	068	072
01	0531064401	RIGHT FRAME		001	001	001
02	0531064402	LEFT FRAME		001	001	001
03	0531064318	FRONT FRAME - 64		001	000	000
03.	0531064446	FRONT FRAME - 68		000	001	000
03..	0531064456	FRONT FRAME - 72		000	000	001
04	0531064133	REAR FRAME - 64		001	000	000
04.	0531064451	REAR FRAME - 68		000	001	000
04..	0531064454	REAR FRAME - 72		000	000	001
05	0531042994	DRAWBAR ASSY	2	001	001	001
06	0531064396	WHEEL		001	001	001
07	0521063202	ESTABILIZER BAR		001	001	001
08	0503060213	WHEEL WITH TIRE 35.4" X 0.80" / 14 CANVAS	3	004	004	004
09	0503034003	61 X 118 SERIAL NUMBER TAG		001	001	001
10	0503034499	HOSE IDENTIFICATION DECAL		001	001	001
11	0503034070	ADHESIVE LABEL		002	002	002
12	0503062027	GNCRP ADHESIVE LABEL SET		002	002	002
13	0503010001	RIVET 3,2 X 5,5		004	004	004
14	0503031428	ATTENTION READ MANUAL DECAL		001	001	001
15	0503033038	DANGER DECAL		001	001	001
16	0503031738	WARNING DECAL		002	002	002
17	0503031087	AUTO CONTROL APPROVED DECAL		001	001	001
18	0503034078	LIFTING POINTS DECAL		003	003	003
19	0503031739	DANGER DECAL		001	001	001
20	0511058405	HYDRAULIC CYLINDER 50,80 X 101,60 X 561 X 252	4	002	002	002
21	0503012260	FELT RING		002	002	002
22	0511059728	FRONT CLEANING ASSEMBLY	5	025	027	027
23	0511059729	REAR CLEANING ASSEMBLY	6	025	027	027
24	0501215229	BEARING FRONT CLEANER		006	006	008
25	0501215228	BEARING REAR CLEANER		006	006	008
26	0571015397	BOARD SHEET		050	054	054
27	0502011587	BEARING AXLE		002	002	002
28	0501064699	SPRING ROD		002	002	002



Item	Code	Description	See page	064	068	072
29	0502020394	SPRING SUPPORT		004	004	004
30	0503031341	2.7 X 8 X 0.5 COMPRESSION SPRING		002	002	002
31	0501040257	3/4" X 38" HOSE SUPPORT ASSY	7	001	001	001
32	0531043098	1 UNC X 4.1/2 G.7 BOLT SET		008	008	008
32A	0503012563	1" X 4-1/2" BOLT		008	008	008
32B	0502012861	1" SQUARE WASHER		008	008	008
32C	0501014509	FLAT WASHER		008	008	008
32D	0501010059	1.5/8 NUT		016	016	016
33	0502010477	HOSE CLAMP		005	005	005
34	0521062959	38,1 X 265 AXLE		002	002	002
35	0501011432	1-1/2" AND 1-5/8 GANG BOLT WRENCH		002	002	002
36	0501061617	1" GANG BOLT WRENCH		001	001	001
37	0501068273	5/8" WRENCH		001	001	001
38	0571019477	TOWER BAR STABILIZER		001	001	001
39	0521042030	WHEEL WITHOUT TIRE S-0514	8	004	004	004
40	0531055421	MANUAL CANISTER ASSY	9	001	001	001
41	0551010280	253 TRANSPORT LOCK		002	002	002
42	0511048088	DRAWBAR JACK	10	001	001	001
43	0503013150	1300 X 3/8" CHAIN		001	001	001
44	0501010098	BOLT 3/4" UNC X 2 C S G.5 ZN		022	022	022
45	0503010797	3/4" X 4" BOLT		004	004	004
46	0503011198	BOLT 3/4" UNC X 6" CS G.5		004	004	004
47	0503011135	BOLT 7/16" UNC X 1.1/2" C S G.5 ZN		005	005	005
48	0503010180	7/16" SPRING WASHER		005	005	005
49	0503011239	1/2" X 2" BOLT		100	108	108
50	0511017302	FLAT WASHER 13,50 X 32,50 X 3,0 ZN		100	108	108
51	0503010019	1/2" SPRING WASHER		100	108	108
52	0503010060	1/2 UNC G.5 ZN HEX NUT		100	108	108
53	0551012215	FLAT WASHER		002	002	002
54	0501017779	FLAT WASHER 32 X 60 X 4,75		006	006	006
55	0503010023	3/4" SPRING WASHER		022	022	022
56	0503010014	3/4" ZN G.5 (HEAVY) UNC HEX NUT		022	022	022
57	0503012183	SNC 3/4" ZIN 1K03097 NUT		008	008	008
58	0501010087	1.1/4" NUT		004	004	004
59	0501011301	1.1/2" UNC 6FPP 2.5/16" NUT		002	002	002
60	0511014394	1.25" X 4.13" COUPLING SHAFT		002	002	002
61	0561014251	COUPLING SHAFT		001	001	001
62	0521010779	31.75 X 95 COUPLING SHAFT		003	003	003
63	0521010547	1.2" X 6.5" COUPLING SHAFT		002	002	002
64	0521010592	1.1" X 3.1" COUPLING SHAFT		002	002	002
65	0541016844	FIXER LOCK		002	002	002
66	0503010523	1/4 X 2 SPLIT PIN		005	005	005
67	0503010010	1/4" X 2.1/2" SPLIT PIN		002	002	002
68	0503010571	1/4" X 1.1/2" SPLIT PIN		002	002	002
69	0503031035	HITCH PIN CLIP		002	002	002
70	0503030012	HITCH PIN CLIP		001	001	001
71	0503030285	HITCH PIN CLIP		002	002	002
72	0503010002	1800 GREASE FITTING		002	002	002
73	0503013171	SEALING 1/2" X 10M 1J51066		001	001	001
74	0561011883	FLAT WASHER		002	002	002
75	0521013710	WASHER SEMIMAN		004	004	004
76		HYDRAULIC CIRCUIT	11			
77		64/68/72D - FRONT AND REAR DISC SECTION	13			

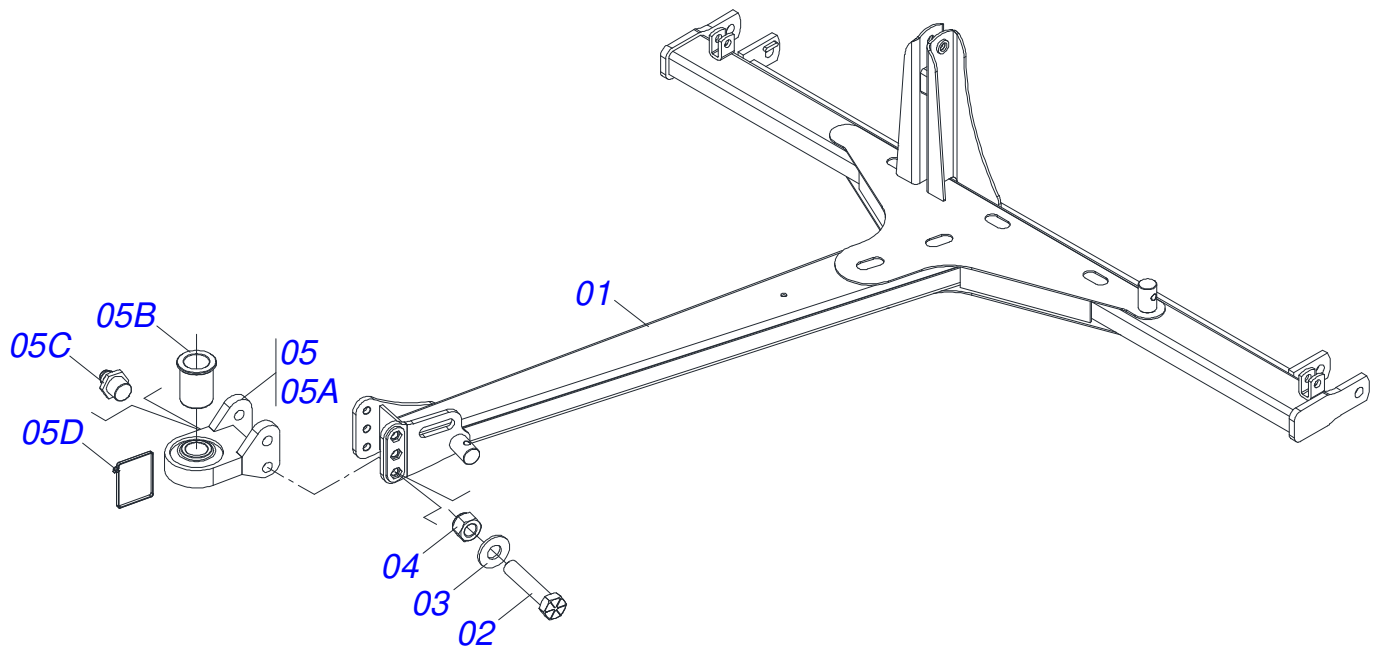

Item	Code	Description	See page	QT
01	0531064394	2830 DRAWBAR		01
02	0503013935	1 UNC X 9 C S G.8 ZN BOLT		02
03	0501010690	FLAT WASHER 26 X 58 X 4,75		02
04	0503018754	NUT 1 - 8 UNC - 2B G8		02
05	0511059885	TRACTOR HITCH ASSY		01
05A	0521067339	TRACTOR HITCH ASSY		01
05B	0581012984	41 X 52.97 SLEEVE		01
05C	0503010002	1800 GREASE FITTING		01
05D	0503018829	NYLON CLAMP 7,8 X 1,8 X 390 MM		01

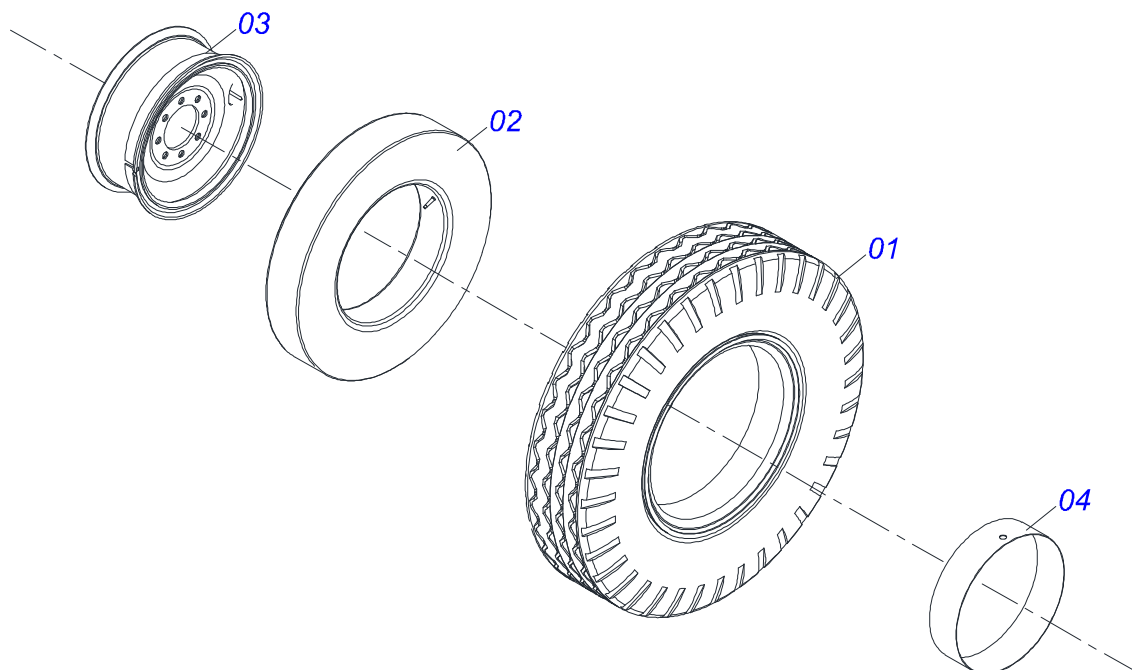

Item	Code	Description	See page	QT
01	0503010494	9.0LX 20" X 14 PLY, TIRE		01
02	0503010057	INNER TIRE		01
03	0501068263	2.6"X0.8"X6.0"X 8F0. 9"X8.0" WHEEL		01
04	0503010470	PROTECTION		01

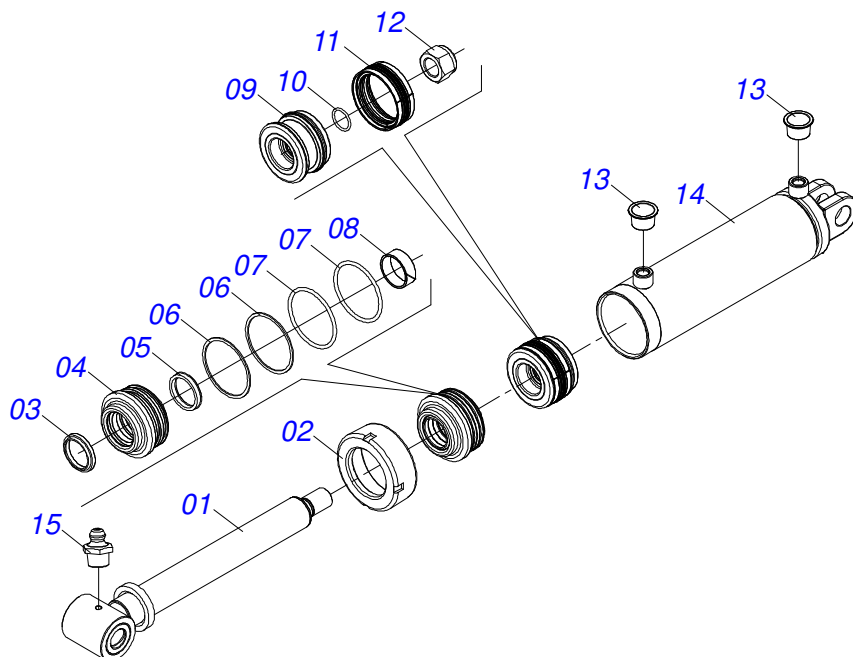

Item	Code	Description	See page	QT
01	0511067445	50,8 X 452,5 EXTENDER		01
02	0502012822	END CAP 4"		01
03	0503015636	SCRAPER SEAL		01
04	0581010678	50,80 X 101 RING SUPPORT		01
05	0503018026	GASKET 1870-2000-375 B POLYMAX		01
06	0503011061	8-342 BACK-UP RING		02
07	0503010338	2-342 N 3006-9B O'RING		02
08	0503018025	RING GUIDE W2-2250-750		01
09	0502012842	50,80 X 101,60 PISTON		01
10	0503010345	2-218 N 3006-9B O'RING		01
11	0503015633	SELEMASTER SEALING		01
12	0503010817	1.1/4" SELF LOCKING NUT		01
13	0503030384	PLUG N-001		02
14	0511066220	101,60 X 369 CYLINDER CASE		01
15	0503010002	1800 GREASE FITTING		01

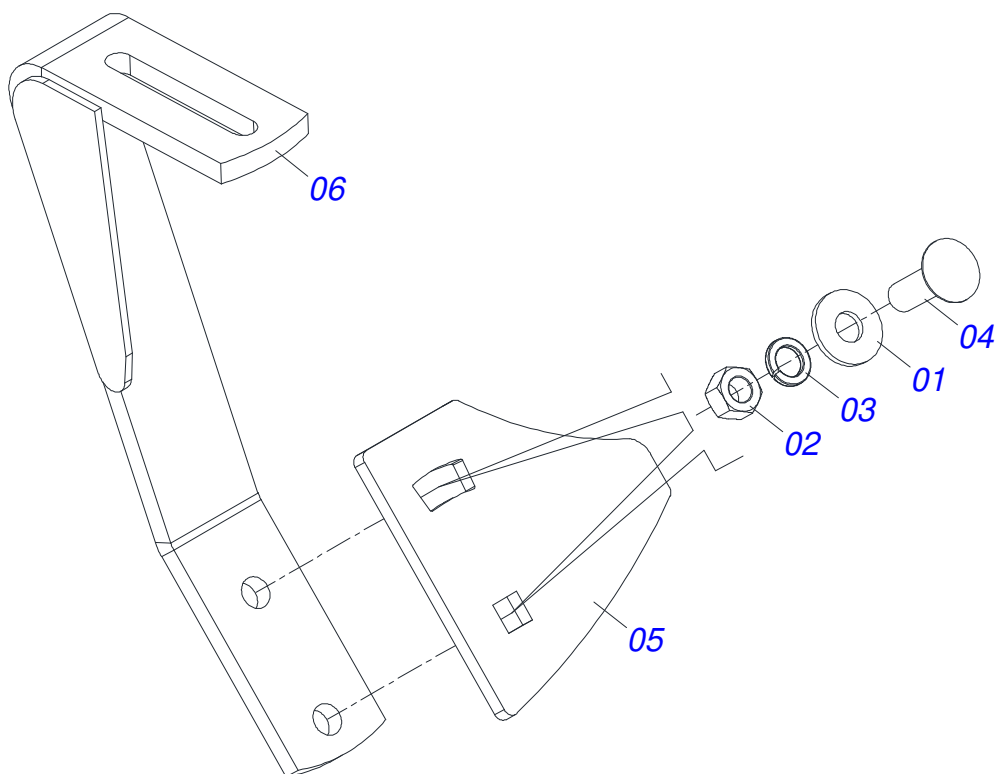

Item	Code	Description	See page	QT
01	0501012140	FLAT WASHER 16,50 X 40 X 4,00 ZN		02
02	0503010013	5/8 UNC G.5 ZN HEX NUT		02
03	0503010027	5/8 SPRING WASHER		02
04	0503012699	BOLT 5/8NC X 2 CAPQ G.5 ZN 1K20548		02
05	0581012586	FRONT / REAR CLEANER PAD		01
06	0521067241	FRONT CLEANING SUPPORT		01

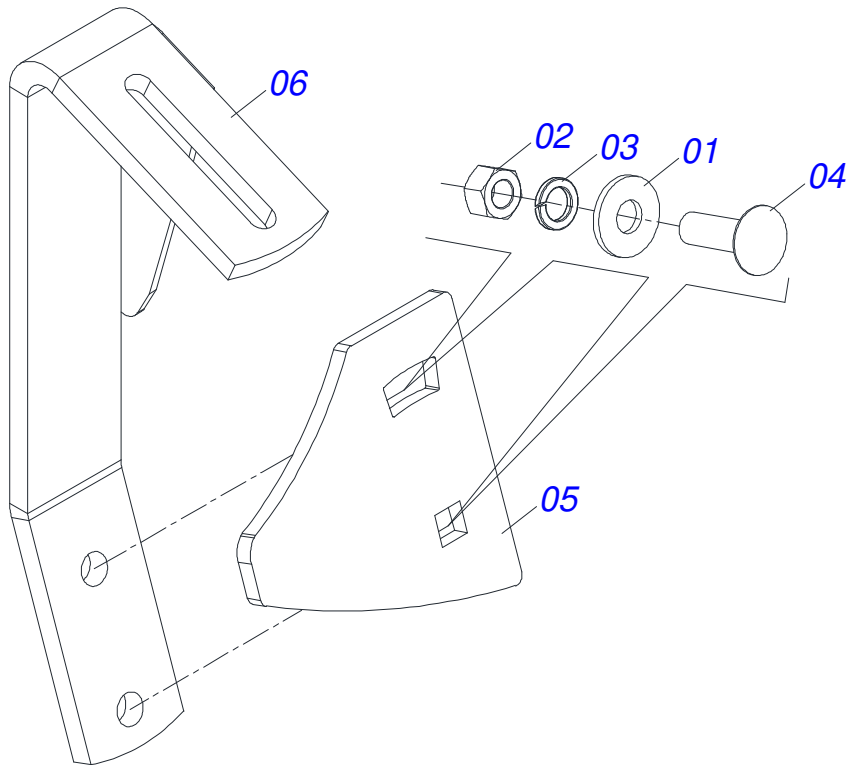

Item	Code	Description	See page	QT
01	0501012140	FLAT WASHER 16,50 X 40 X 4,00 ZN		02
02	0503010013	5/8 UNC G.5 ZN HEX NUT		02
03	0503010027	5/8 SPRING WASHER		02
04	0503012699	BOLT 5/8NC X 2 CAPQ G.5 ZN 1K20548		02
05	0581012586	FRONT / REAR CLEANER PAD		01
06	0521067242	REAR CLEANER SUPPORT		01

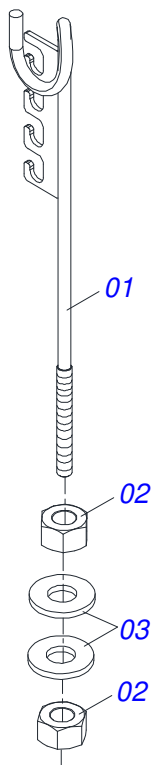

Item	Code	Description	See page	QT
01	0511067334	HOSE SUPPORT		01
02	0503010014	3/4" ZN G.5 (HEAVY) UNC HEX NUT		02
03	0501010322	20,50 X 46 X 4,00 ZN FLAT WASHER		02

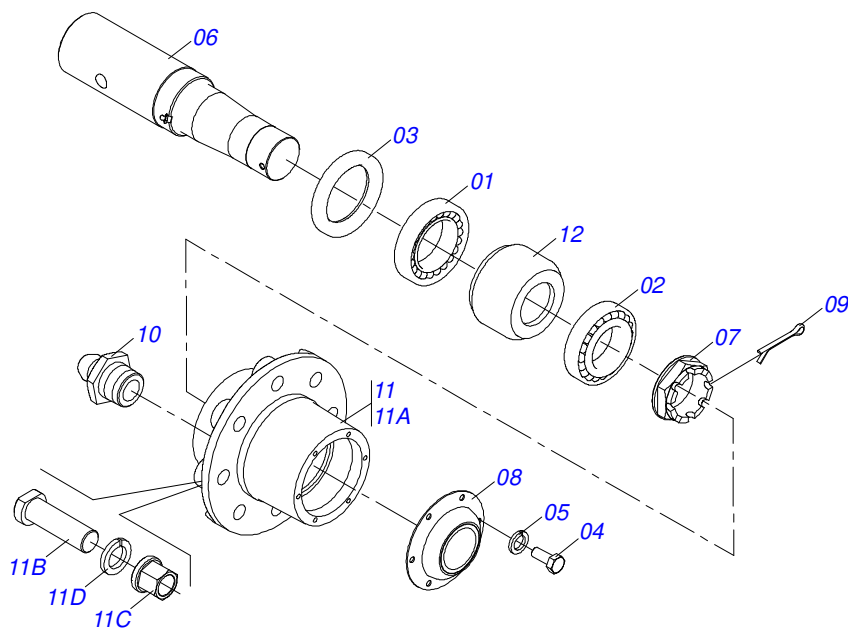

Item	Code	Description	See page	QT
01	0503010059	33287/33462 ROLLER BEARING		01
02	0503010007	3982/3920 ROLLER BEARING		01
03	0503010050	SEAL 00085-B		01
04	0503010240	BOLT		06
05	0503011444	SPRING WASHER 5/16"		06
06	0571013653	POINT AXIS 88,80 X 430		01
07	0502040080	FLANGE NUT R.2.1/2" UN		01
08	0541013225	WHEEL HUB LID		01
09	0503012231	1/4" X 3" SPLIT PIN		01
10	0503010002	1800 GREASE FITTING		01
11	0501110751	HUB AND SPINDLE WITH BOLT		01
11A	0502040522	HUB CARRYING-WHEELS		01
11B	0503011339	M22 X 1,5 X 72 BOLT		08
11C	0503011341	M22 X 0.6" NUT GR8		08
11D	0503011340	SPHERICAL SPRING WASHER		08
12	1882970002	GREASE		01

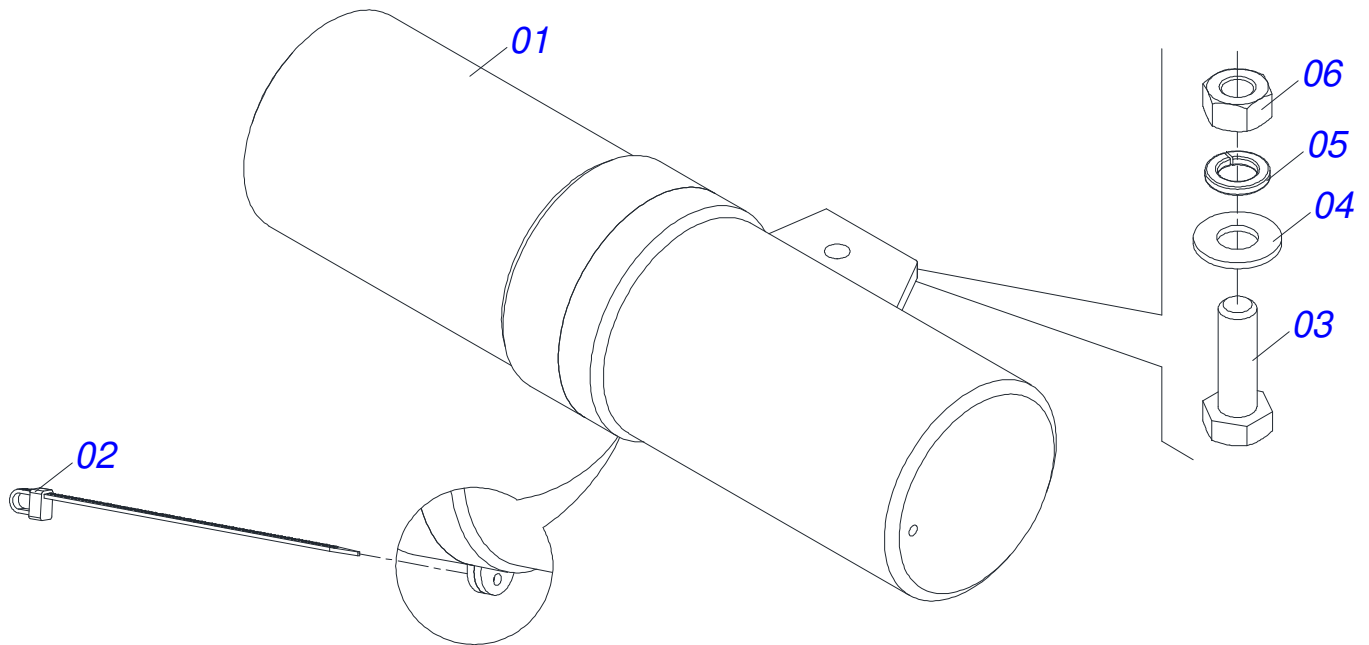

Item	Code	Description	See page	QT
01	0503060100	SUPPORT INSTRUCTION MANUAL		01
02	0503010267	NYLON CLAMP 3,60 X 1,3 X 155 MM		01
03	0503010363	BOLT 5/16 UNC X 1 C S G.2 ZN		01
04	0501010694	FLAT WASHER 32,50 X 75 X 4,75		01
05	0503010179	LOCK WASHER 5/16 ZN 1K01528		01
06	0503010337	NUT 5/16 UNC G.5 ZN		01

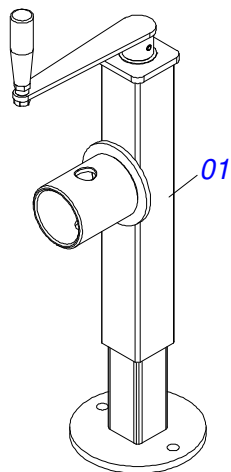

Item	Code	Description	See page	QT
01	0503062227	DRAWBAR JACK		01

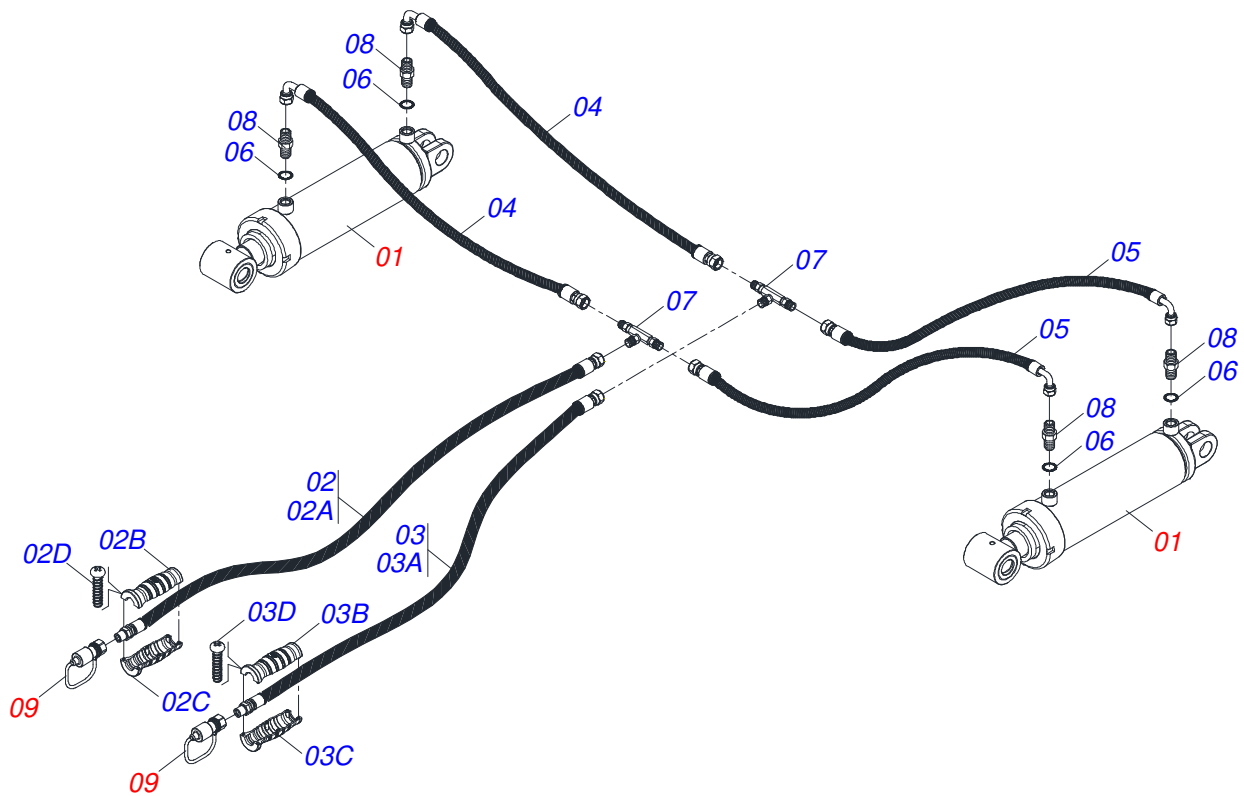

Item	Code	Description	See page	QT
01	0511058405	HYDRAULIC CYLINDER 50,80 X 101,60 X 561 X 252	4	02
02	0531055939	3/8" X 314.96" TR-TM BLACK/BLUE HOSE		01
02A	0501081778	3/8" X 314.96" TR-TM HOSE		01
02B	0503034492	HYDRAULIC HOSE GRIP (BLACK)		01
02C	0503034494	HYDRAULIC HOSE GRIP (BLUE)		01
02D	0503018952	PH 2,5 X 10 ZB PLASTIC BOLT		06
03	0531055940	3/8" X 314.96" TR-TM BLACK/RED HOSE		01
03A	0501081778	3/8" X 314.96" TR-TM HOSE		01
03B	0503034495	HYDRAULIC HOSE GRIP (RED)		01
03C	0503034492	HYDRAULIC HOSE GRIP (BLACK)		01
03D	0503018952	PH 2,5 X 10 ZB PLASTIC BOLT		06
04	0501081831	3/8" X 59.05" TR-TC HOSE		02
05	0501080348	3/8" X 47,24" TR-TC HOSE		02
06	0503010190	2-114 N 3006-9B O'RING		04
07	0503011271	3/4" UNF "T" CONNECTION T 3 SIDES		02
08	0501010617	NIPLE 3/4" NF X 3/4" NF HEX. 7/8" X 44		04
09	0501053834	MALE QUICK COUPLER	12	02

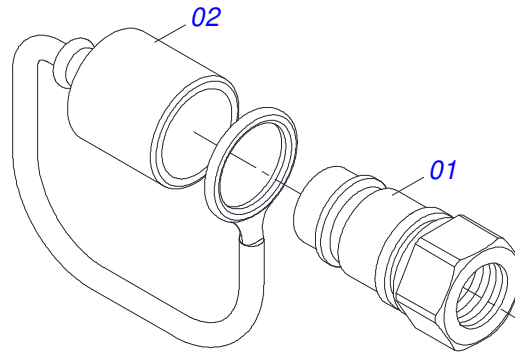

Item	Code	Description	See page	QT
01	0503011627	MALE QUICK COUPLER AGR 1/2 NPT		01
02	0503011882	MALE QUICK COUPLER CAP		01

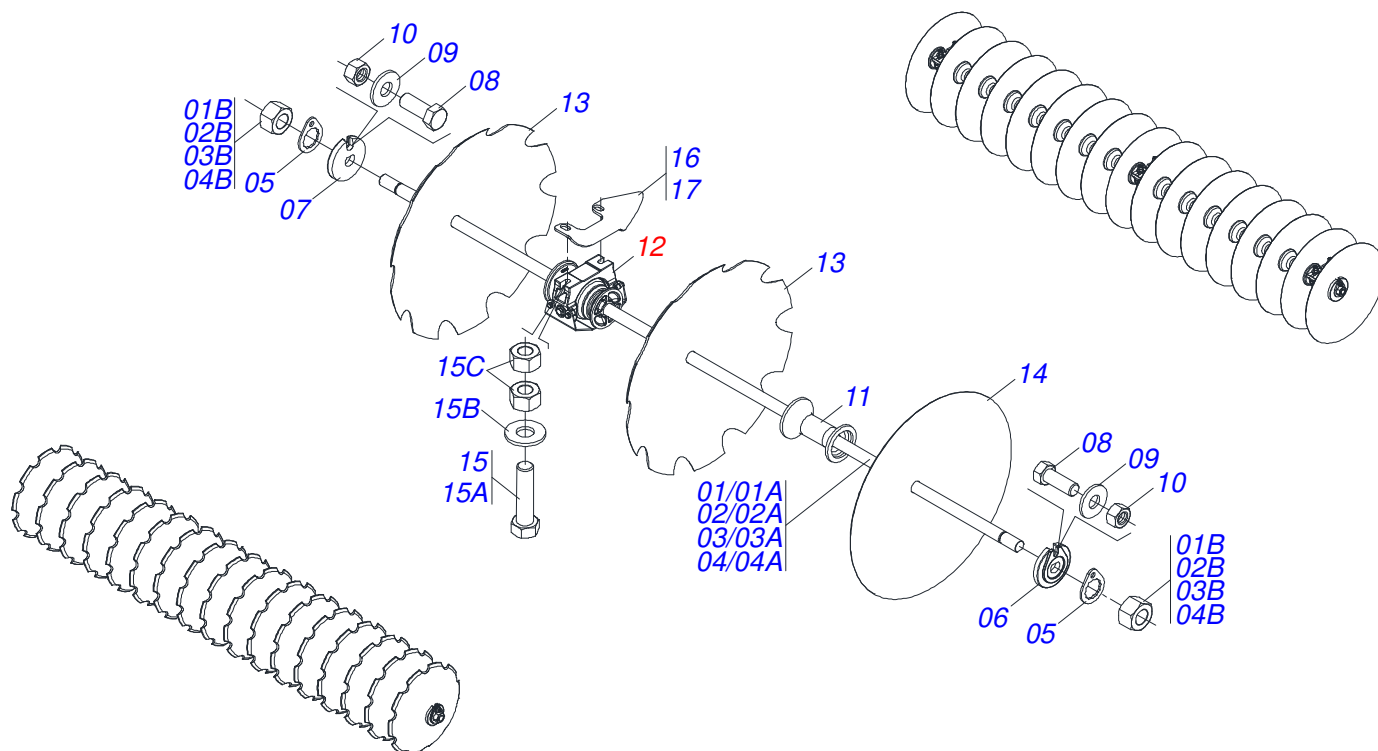

Item	Code	Description	See page	64	68	72
01	0511045577	1.1/2 X 1530 AXLE WITH NUTS		00	00	02
01A	0551013704	1.1/2 X 1530 AXLE		00	00	02
01B	0501810110	1.1/2 NC 6FPP NUT		00	00	04
02	0531043234	1.1/2 X 2735 AXLE WITH NUTS		00	00	04
02A	0501215420	1.1/2 X 2735 AXLE		00	00	04
02B	0501810110	1.1/2 NC 6FPP NUT		00	00	08
03	0531042993	1.1/2 X 3135 AXLE WITH NUTS		04	00	00
03A	0501215272	1.1/2 X 3135 AXLE		04	00	00
03B	0501010110	1.1/2 NC 6FPP 2.3/8 HEXAGONAL NUT		08	00	00
04	0531043207	1.1/2 X 3335 AXLE WITH NUTS		00	04	00
04A	0501215406	1.1/2 X 3335 AXLE		00	04	00
04B	0501010110	1.1/2 NC 6FPP 2.3/8 HEXAGONAL NUT		00	08	00
05	0501018592	1.5/8 HEX 60,0/60,2 LOCK NUT		08	08	12
06	0502010872	1-1/2" INNER AXLE WASHER		04	04	06
07	0502010871	EXTERNAL AXLE WASHER 1.1/2"		04	04	06
08	0503011267	BOLT 5/8" UNC X 1.1/2 C S G.5 ZN		08	08	08
09	0501012140	FLAT WASHER 16,50 X 40 X 4,00 ZN		08	08	08
10	0503012412	5/8" UNC SELF LOCKING NUT		08	08	08
11	0502011594	SPACER		48	52	50
12	0531042480	196 X 1.1/2 DMO AGRICULTURAL BEARING WITH 14 PROTECTION SUPPORT		12	12	16
13	0602029413	DR 22 X 6,00 C74AF02FR1.9/16 10R		64	68	72
13.	0602030283	DR 24 X 6,00 C84AF02FR1.9/16 10R		64	68	72
14	0601029409	DL 22 X 6,00 C74AF02FR1.9/16		64	68	72
14.	0601030305	DL 24 X 6,00 C84AF02FR1.9/16		64	68	72
15	0521048902	SCREW ASSEMBLY 5/8 UNC 3		24	24	24
15A	0501011541	5/8 UNC X 3 CS G.5 ZN1K28066 BOLT		24	24	24
15B	0501012140	FLAT WASHER 16,50 X 40 X 4,00 ZN		24	24	24
15C	0503010013	5/8 UNC G.5 ZN HEX NUT		48	48	48
16	0501215229	BEARING FRONT CLEANER		06	06	08
17	0501215228	BEARING REAR CLEANER		06	06	08

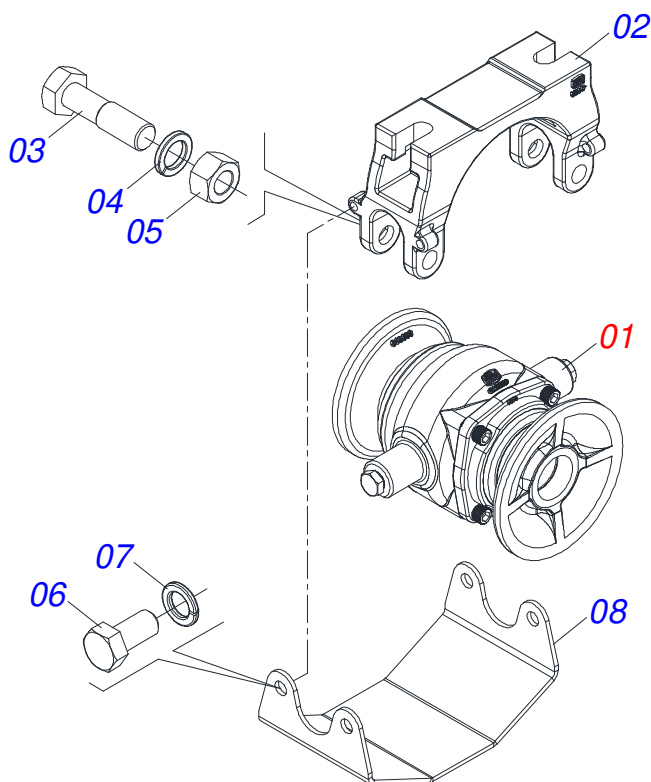

Item	Code	Description	See page	QT
01	0531055221	196 X 1.1/2 IMP DMO AGRICULTURAL BEARING	15	01
02	0502013047	BEARING SUPPORT		01
03	0501011541	5/8 UNC X 3 CS G.5 ZN1K28066 BOLT		02
04	0503010027	5/8 SPRING WASHER		02
05	0503010013	5/8 UNC G.5 ZN HEX NUT		02
06	0503011334	3/8 UNC X 3/4 CS G.5 ZN BOLT		04
07	0503010025	3/8" SPRING WASHER		04
08	0581014143	SWIVEL OIL BATH BEARING WEAR PLATE		01

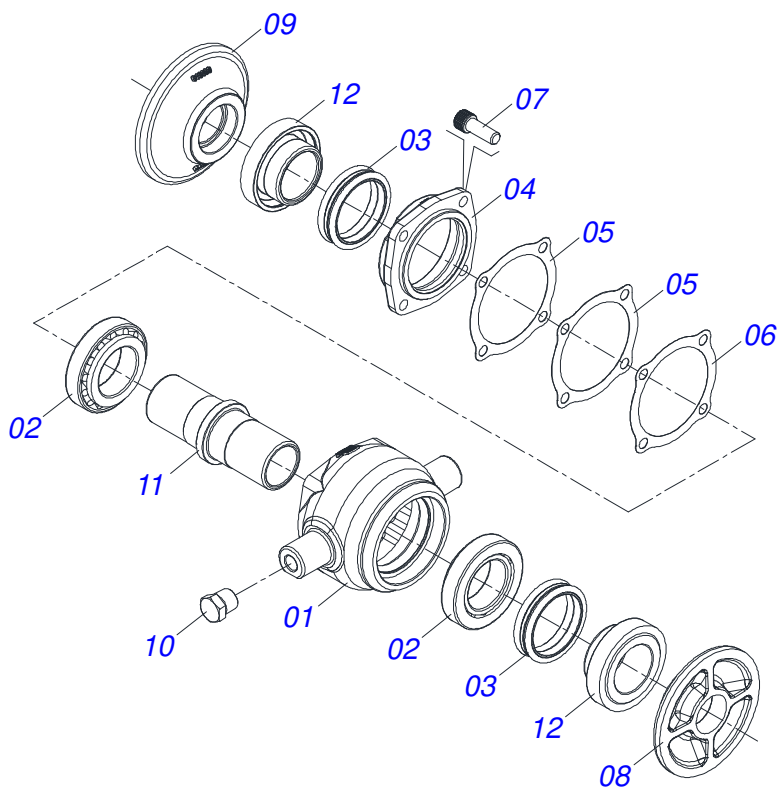

Item	Code	Description	See page	QT
01	0502012839	BEARING HOUSING 182/192,5		01
02	0503010006	32210 ROLLER BEARING		02
03	0503030026	SEAL LP JB-253		02
04	0502020424	HOUSING CAP 182/192,225		01
05	0503030013	4.4" X 3.5" X 0.004" JOINT		02
06	0503030684	4.4" X 3.5" X 0.004" JOINT		01
07	0503010134	3/8" X 1" BOLT		04
08	0501216951	INNER FLANGE		01
09	0501216952	OUTER FLANGE		01
10	0503010856	OIL PLUG R 3/8 BSPT		02
11	0502040061	182/192,5 AXLE		01
12	0502010541	SEAL HOLDER		02

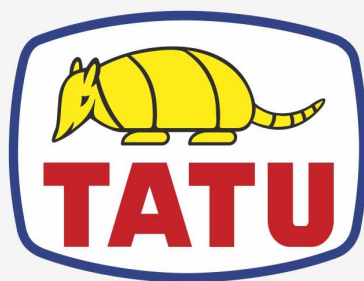

MARCHESAN

Technical Publications | Elaboration and Revision

ALESSANDRA PATRICIA KAWAHARA CARRILI

www.marchesan.com.br

