

**CHASER BIN**

## **DCA2 10500 MC WITH HYDRAULIC DRIVE**

**Code:** 0501093167  
**Series:** S-0114  
**Revision:** 01  
**Date Revision:** FEVEREIRO/2023

# **PARTS CATALOGUE**

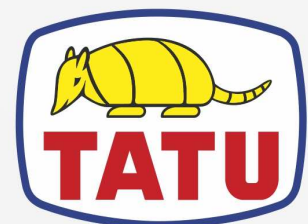

**MARCHESAN**



# PRODUCTS

Code	Description
0109090212	DCA2 10500 MC C/ABAFADOR/ACION HIDR S-0114
0109090215	DCA2 10500 MC C/ACIONAM HIDR S-0114

## ATTENTION: IMPORTANT

Marchesan S.A. reserves the right to improve and/or modify the technical features of its products, without obligation to do the same with those products already sold and without prior knowledge of the dealer or the customer. The photos are only illustrative.



**MARCHESAN**

# INDEX

0909096088	ASSY FRAME	.....	1
0521047125	ASSY FRAME WITH HYDRAULIC OPERATION	.....	2
0521058123	HYDRAULIC DRIVE SET	.....	3
0511053588	MOTOR HYDRAULIC OMP 80 WITH NIPPLE 7/8 NIPPE 7/8	.....	4
0511054496	TENSIONER SMALEER ASSY	.....	5
0521057978	SIMPLE HYDRAULIC ACTUATION HOSE SET	.....	6
0501053834	MALE QUICK COUPLER	.....	7
0521058094	SUPPORT HOSE	.....	8
0521057951	SUPPORT SIMPLE HYDRAULIC DRIVE	.....	9
0521057953	BLOCK HYDAC	.....	10
0521057952	FILTER PRES PARKER HDA FP20 10FV 06B LV6	.....	11
0521057599	FILTER PRESS PARKER HDA FP20 10FV 06B LV6 WITH NIPPLE	.....	12
0511054497	TENSIONER LARGER ASSY	.....	13
0501054846	SLUICE VALVE SUPPORT	.....	14
0511059094	SHAFT BEARING THREADED	.....	15
0503062157	DRAWBAR JACK	.....	16
0511059633	ASSY LADDER	.....	17
0501054847	SLUICE VALVE COVER ASSY	.....	18
0511059024	ENGATE TRATOR COMPLETO	.....	19
0511042281	BELL CRANK FIXER SUPPORT	.....	20
0501056347	CARRYING WHEELS WITHOUT TIRE	.....	21
0531050245	ASSY MANUAL DOOR	.....	22
0521050038	FRAME WITH BUCKET SEMI MOUNTED	.....	23
0511059305	REAR PROTECTION WITH MINOR PROTECTOR	.....	24
0501044308	AGRICULTURAL BEARING ASSY	.....	25
0501047985	REDUCER	.....	26
0501051774	38Z CROWN	.....	27
0501046802	BELT TENSIONER ASSY	.....	28
0501051782	RIGHT BEARING SUPPORT DISC	.....	29
0501051783	LEFT BEARING SUPPORT DISC	.....	30
0501048000	AGRICULTURAL BEARING	.....	31
0501051972	DISTRIBUTOR RIGHT DISC ASSY	.....	32
0501051973	DISTRIBUTOR LEFT DISC ASSY	.....	33
0511041213	AGRICULTURAL BEARING	.....	34
0531050244	PROTECTOR DISC	.....	35
0521046819	ASSY FRAME	.....	36
0511056261	HYDRAULIC DRIVE ASSY	.....	37
0531052379	DAMPER ASSY	.....	38
0511059222	WHEEL WITH TIRE RIGHT SIDE	.....	39
0511059223	WHEEL WITH LEFT SIDE TIRE	.....	40

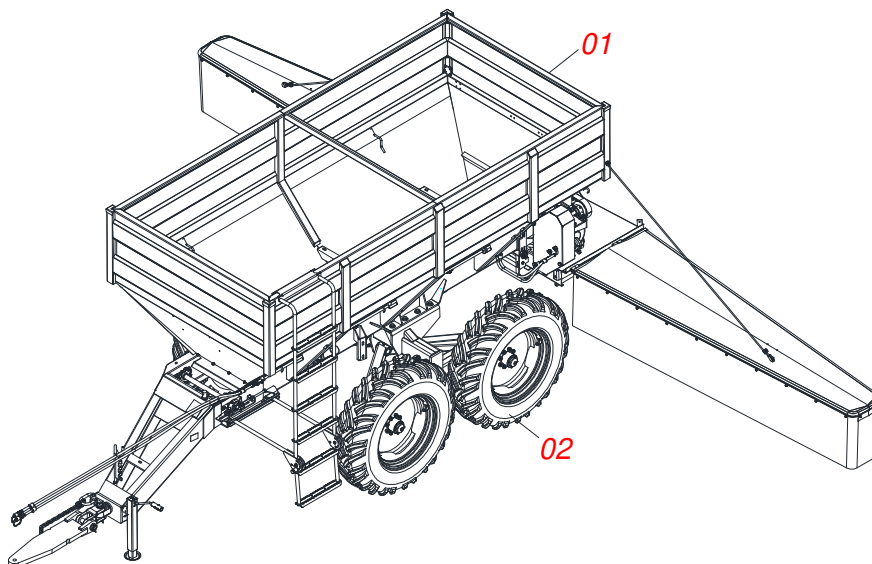

Item	Code	Description	See page	QT
01	0521047125	ASSY FRAME WITH HYDRAULIC OPERATION	2	01
01.	0521046819	ASSY FRAME	36	01
02	0511059222	WHEEL WITH TIRE RIGHT SIDE	39	02
02.	0511059223	WHEEL WITH LEFT SIDE TIRE	40	02

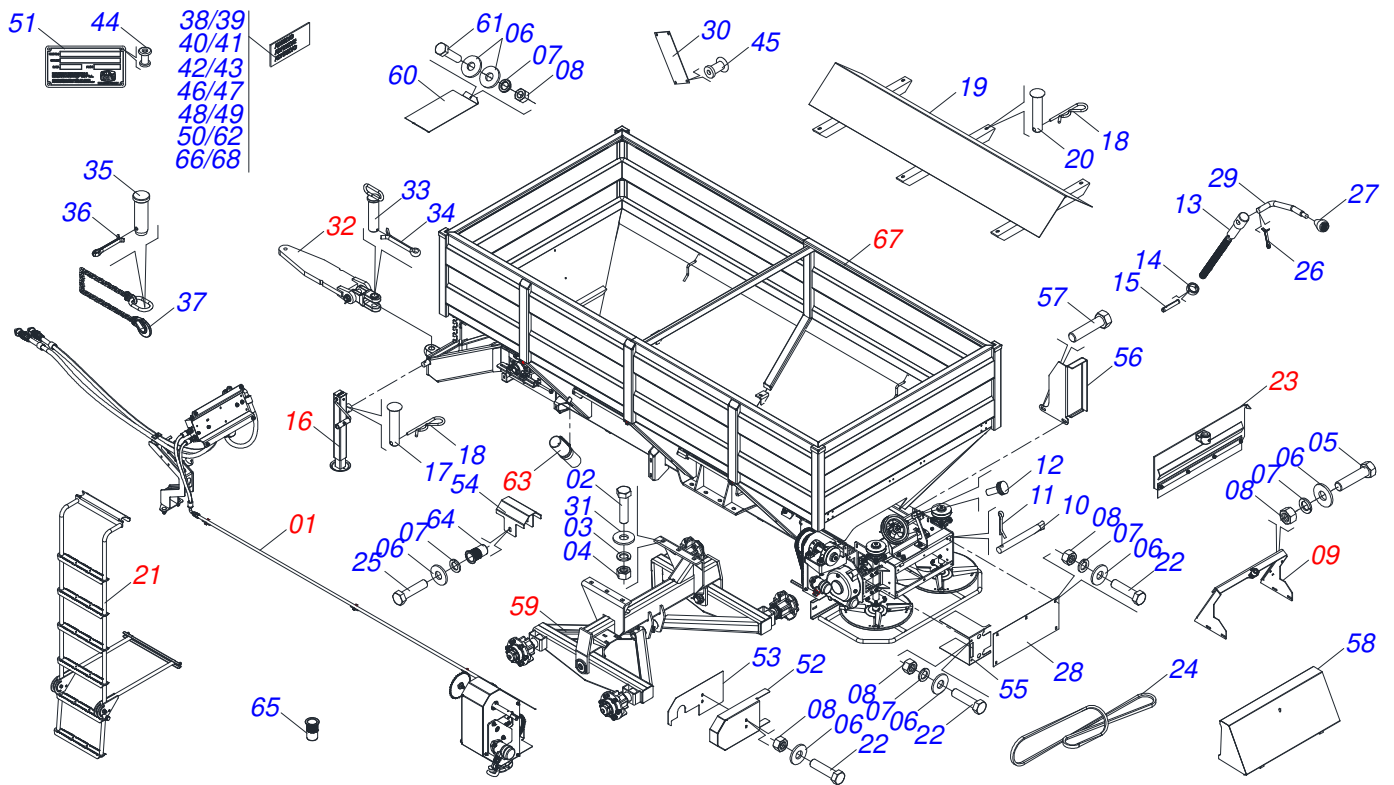

Item	Code	Description	See page	QT
01	0521058123	HYDRAULIC DRIVE SET	3	01
02	0501010125	3/4" X 2-1/2" BOLT		08
03	0503010023	3/4" SPRING WASHER		08
04	0503010014	3/4" HEX NUT		08
05	0503010751	C3/8" X 1.1/4" HEX BOLT G.5		04
06	0501010984	10,50 X 27 X 3,00 FLAT WASHER		13
07	0503010025	3/8 SPRING WASHER		18
08	0503010026	3/8" NUT		14
09	0501054846	SLUICE VALVE SUPPORT	14	01
10	0501017574	0.3" X 2.7" AXLE		02
11	0503010140	1/8" X 3/4" COTTERPIN		02
12	0503010386	CABLE		01
13	0561014861	REGULATOR		01
14	0511013015	SLEEVE		01
15	0503010561	SPRING PIN		01
16	0503062157	DRAWBAR JACK	16	01
17	0521010549	COUPLING SHAFT		01
18	0503030168	HITCH PIN CLIP		07
19	0511064692	DEFLECTOR		01
20	0521017623	0.5" X 1.5" COUPLING SHAFT		06
21	0511059633	ASSY LADDER	17	01
22	0503010237	3/8" X 1" BOLT		12
23	0501054847	SLUICE VALVE COVER ASSY	18	01
24	0503019347	BELT		01
25	0503010256	3/8" X 3/4" BOLT		02
26	0503010257	1/8" X 1" COTTERPIN		01
27	0503030878	LEVER CRANK		01
28	0501019460	REAR PROTECTION		01
29	0521011107	CRANK BODY		01
30	0503030751	REGULATOR PLATE		01
31	0501010322	FLAT WASHER		16



**DCA2 10500 MC WITH HYDRAULIC DRIVE**  
**ASSY FRAME WITH HYDRAULIC OPERATION**

Page 2  
0521047125

Item	Code	Description	See page	QT
32	0511059024	ENGATE TRATOR COMPLETO	19	01
33	0511066176	HITCH PIN		01
34	0503010010	1/4" X 2.1/2" COTTERPIN		01
35	0581011220	COUPLING SHAFT		01
36	0503010131	3/16" X 1-1/2" COTTERPIN		01
37	0503013150	1300 X 3/8 CHAIN		01
38	0503031818	ADHESIVE LABEL		01
39	0503031859	ADHESIVE LABEL DANGER		01
40	0503031827	LUBRICATE AND RETIGHTEN DAILY DECAL		01
41	0503031427	ADHESIVE LABEL		01
42	0503031428	READ MANUAL DECAL		01
43	0503031087	ADHESIVE LABEL		01
44	0503010001	3.2 X 5.5 RIVET		04
45	0503012209	RIVET POP		04
46	0503032425	ADHESIVE LABEL ATTENTION		01
47	0503034393	ADHESIVE LABEL		02
48	0503034392	ADHESIVE LABEL		04
49	0503034395	ADHESIVE LABEL		02
50	0503034394	ADHESIVE LABEL		02
51	0503034003	SERIAL NUMBER TAG 61 X 118		01
52	0591016134	PROTECTION COVER		01
53	0591016135	REAR COVER PROTECTION COVER		01
54	0591016133	COVER PROTECTION AXLE		01
55	0581017497	COUPLING PROTECTION		01
56	0581017492	SIDE PROTECTION BELT		01
57	0503010849	3/8" X 1-1/2" BOLT		04
58	0501069840	REAR COVER PROTECTION		01
59	0511042281	BELL CRANK FIXER SUPPORT	20	01
60	0581017442	FRONT PROTECTION		01
61	0503010849	3/8" X 1-1/2" BOLT		02
62	0503034648	ADHESIVE LABEL		01
63	0531050245	ASSY MANUAL DOOR	22	01
64	0503019416	RIVET SCREW THREAD INTERNAL		02
65	0503019413	THREAD SCREW INTERNAL		04
66	0503035157	ADHESIVE LABEL DISTRIBUTOR LIMESTONE		01
67	0521050038	FRAME WITH BUCKET SEMI MOUNTED	23	01
68	0503036144	MAXIMUM SPEED ADHESIVE LABEL		01

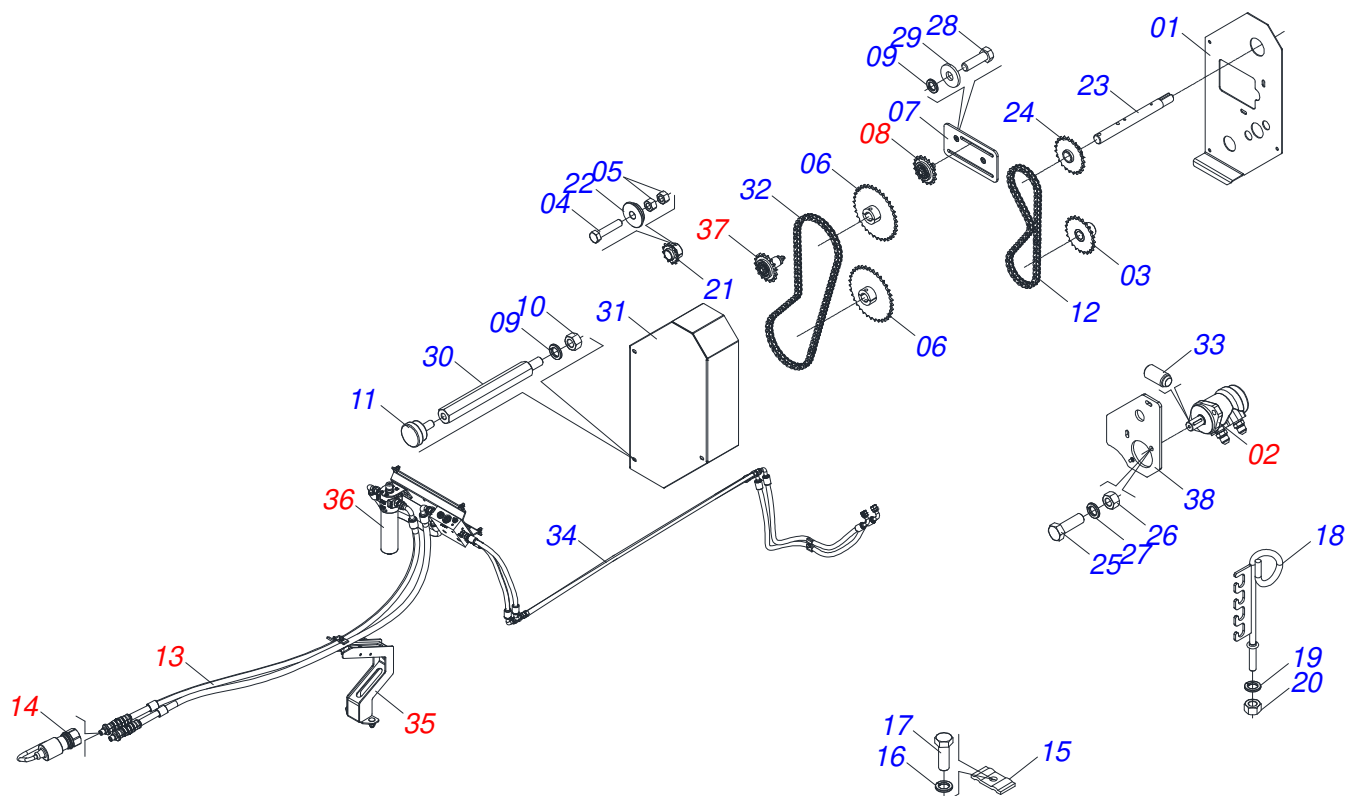

Item	Code	Description	See page	QT
01	0571015447	PROTECTION REAR		01
02	0511053588	MOTOR HYDRAULIC OMP 80 WITH NIPPLE 7/8 4 NIPPE 7/8		01
03	0521064566	GEAR HIDRAULIC MOTOR		01
04	0503011141	3/8" X 2-3/4" BOLT		04
05	0503010026	3/8" NUT		08
06	0501069020	35Z GEAR		02
07	0521064691	SUPPORT TENSIONER		01
08	0511054496	TENSIONER SMALEER ASSY	5	01
09	0503010025	3/8 SPRING WASHER		07
10	0503010026	3/8" NUT		05
11	0503010386	CABLE		03
12	0503013061	50-1 CHAIN X 64 LINK + REDUCTION		01
13	0521057978	SIMPLE HYDRAULIC ACTUATION HOSE SET	6	01
14	0501053834	MALE QUICK COUPLER	7	02
15	0531011180	UPPER BODY CLIP		04
16	0503010180	7/16" SPRING WASHER		04
17	0503011102	BOLT 7/16 UNC X 1.1/4 C S G.5 ZN		04
18	0501060409	HOSE SOPPORT ASSY		01
19	0503010023	3/4" SPRING WASHER		01
20	0503010014	3/4" HEX NUT		01
21	0501069017	12Z GEAR		01
22	0581011125	LOCK WASHER		01
23	0571015448	DRIVE AXLE		01
24	0521063041	GEAR 23Z		01
25	0503010920	1/2 UNC X 1.1/2 C S G.5 ZN BOLT		02
26	0503010060	1/2 UNC G.5 ZN HEX NUT		02
27	0503010019	1/2" SPRING WASHER		02
28	0503010849	3/8" X 1-1/2" BOLT		04
29	0501010984	10,50 X 27 X 3,00 FLAT WASHER		06
30	0571015189	PRISONER 3/8"		03
31	0571015450	CHAIN CAP		01



HYDRAULIC DRIVE SET

0521058123

Item	Code	Description	See page	QT
32	0503013003	50-1 CHAIN X 79 LINK + REDUCTION + MENDING		01
33	0503017021	M8 X 0.5" BOLT		01
34	0531060946	OIL DUCT 3000 R.7/8 UNF 14 FPP		02
35	0521058094	SUPPORT HOSE	8	01
36	0521057951	SUPPORT SIMPLE HYDRAULIC DRIVE	9	01
37	0511054497	TENSIONER LARGER ASSY	13	01
38	0571015182	HIDRAULIC MOTOR SUPPORT		01



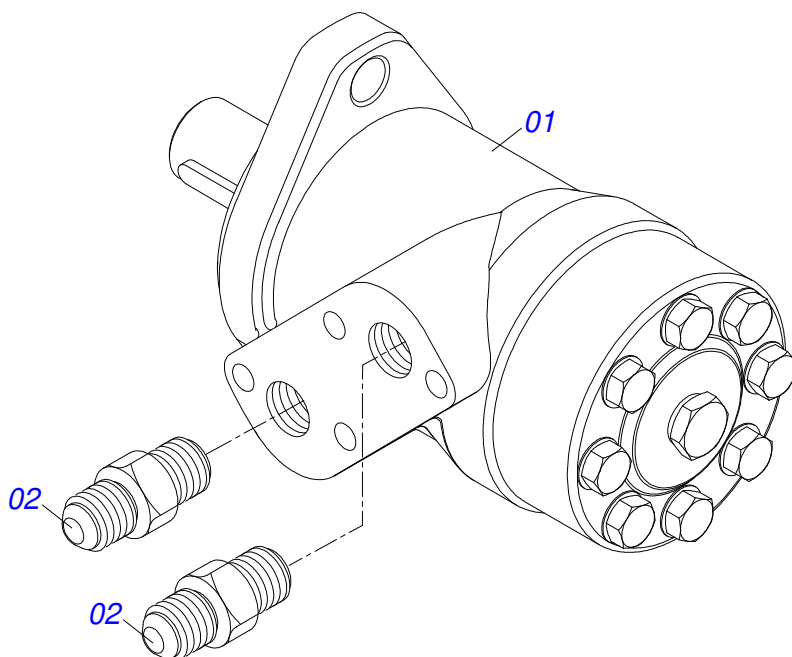

Item	Code	Description	See page	QT
01	0503016055	PARKER OMP 80 ISOBUS HYDRAULIC MOTOR		01
02	0511014065	7/8" NF X R1/2NPT X 52 NIPPLE		02

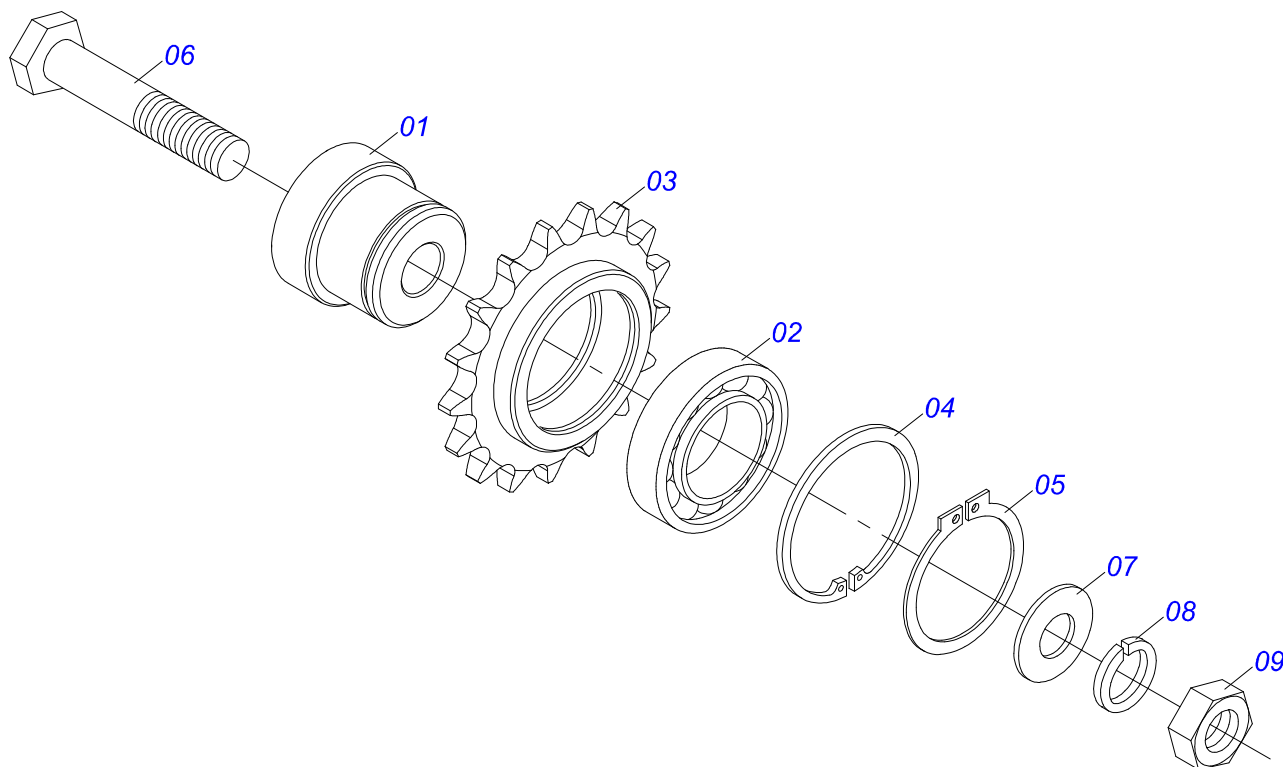

Item	Code	Description	See page	QT
01	0571015185	AXLE TIGHTENER 26		01
02	0503011410	ROLLER BEARING		01
03	0511061836	17Z GEAR		01
04	0503011105	SEAL RING		01
05	0503010406	501025 CLAMPING RING (FOR AXLE)		01
06	0501010096	3/8" X 2" BOLT		01
07	0501010984	10,50 X 27 X 3,00 FLAT WASHER		01
08	0503010025	3/8 SPRING WASHER		01
09	0503010026	3/8" NUT		01

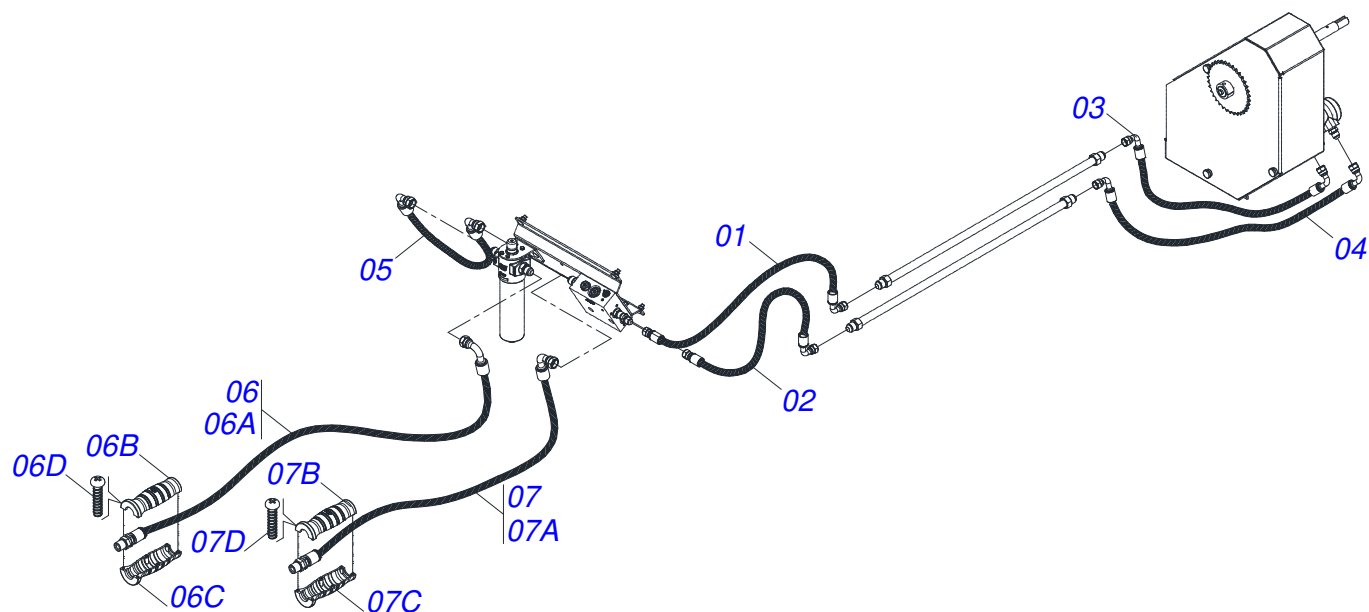

Item	Code	Description	See page	QT
01	0501081235	1/2 X 650 TR- TC HOSE		01
02	0501080218	1/2 X 750 HOSE		01
03	0501082303	HOSE 1/2 X 930 TC-TC 90G		01
04	0501082304	1/2 X 1000 TR-TC HOSE		01
05	0501081365	HOSE 3/4 X 680 TC-TC 180G		01
06	0521057977	HOSE 3/4 X 2100 TC-TM AMARILLO/AZUL		01
06A	0501082295	HOSE 3/4 X 2100 TC - TM R.1/2NPT		01
06B	0503034493	HYDRAULIC HOSE DEPTH (YELLOW)		01
06C	0503034494	HYDRAULIC HOSE GRIP (BLUE)		01
06D	0503018952	PLASTIC BOLT		06
07	0521057976	HOSE 3/4 X 2100 TC-TM YELLOW/RED		01
07A	0501082295	HOSE 3/4 X 2100 TC - TM R.1/2NPT		01
07B	0503034493	HYDRAULIC HOSE DEPTH (YELLOW)		01
07C	0503034495	HYDRAULIC HOSE GRIP (RED)		01
07D	0503018952	PLASTIC BOLT		06

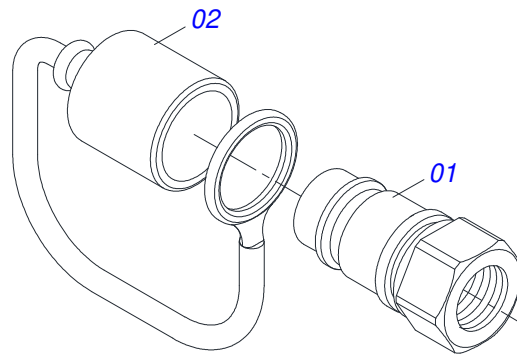

Item	Code	Description	See page	QT
01	0503011627	MALE QUICK COUPLER AGR 1/2 NPT		01
02	0503011882	MALE QUICK COUPLER CAP		01

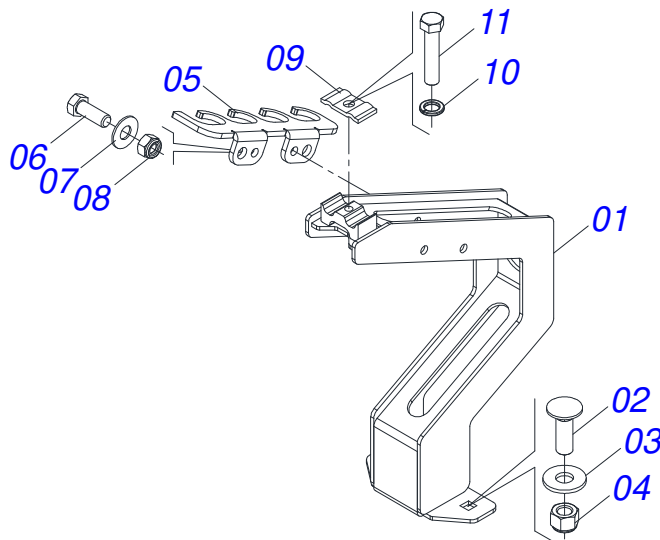

Item	Code	Description	See page	QT
01	0531060944	HOSE HOLDER ASSY		01
02	0503014378	1/2" X 1-1/2" BOLT		02
03	0511017302	FLAT WASHER 13,50 X 32,50 X 3,0 ZN		02
04	0503010589	1/2" UNC SELF ADJUSTING NUT		02
05	0591018556	HOSE FIXER ASSY		01
06	0503011087	3/8" X 1" BOLT		02
07	0501013518	FLAT WASHER		02
08	0503013357	3/8 SELF-ADJUSTING NUT		02
09	0531011180	UPPER BODY CLIP		01
10	0503010180	7/16" SPRING WASHER		01
11	0503011173	7/16" X 2" BOLT		01

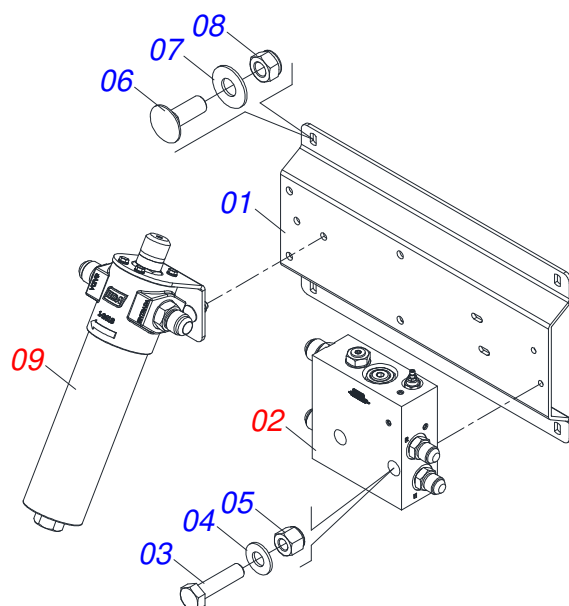

Item	Code	Description	See page	QT
01	0591013644	SUPPORT SET HIDRAULICO		01
02	0521057953	BLOCK HYDAC	10	01
03	0503011766	5/16" X 2-1/2" BOLT		02
04	0501010694	FLAT WASHER		02
05	0503013759	NUT		02
06	0501011643	3/8 X 1" BOLT		04
07	0501013518	FLAT WASHER		04
08	0503013357	3/8 SELF-ADJUSTING NUT		04
09	0521057952	FILTER PRES PARKER HDA FP20 10FV 06B LV6	11	01

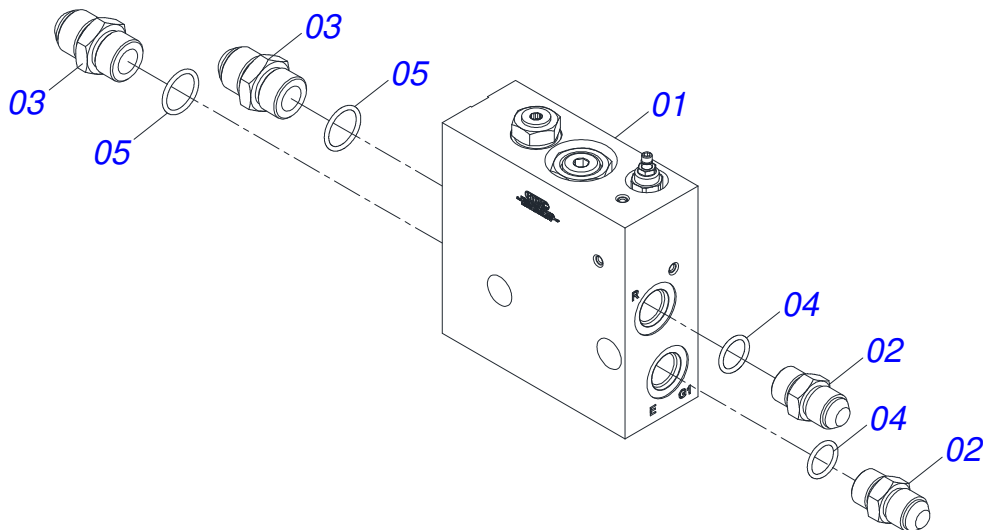

Item	Code	Description	See page	QT
01	0503063271	BLOCK		01
02	0501010590	NIPPLE		02
03	0501010589	R. 1.1/16UN SEXT 1.1/4 X 52 NIPPLE		02
04	0503010045	O'RING		02
05	0503011109	2-119 N 3006-9B O'RING		02

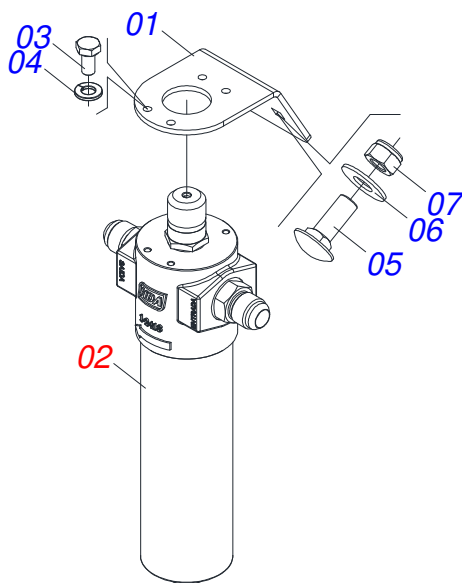

Item	Code	Description	See page	QT
01	0591013645	PRESSURE FILTER SUPPORT		01
02	0521057599	FILTER PRESS PARKER HDA FP20 10FV 06B LV6 12 WITH NIPPLE		01
03	0503011812	BOLT M6 X 1 X 12 CS 8.8 ZN		04
04	0503010143	1/4" SPRING WASHER		04
05	0501011643	3/8 X 1" BOLT		02
06	0501013518	FLAT WASHER		02
07	0503013357	3/8 SELF-ADJUSTING NUT		02



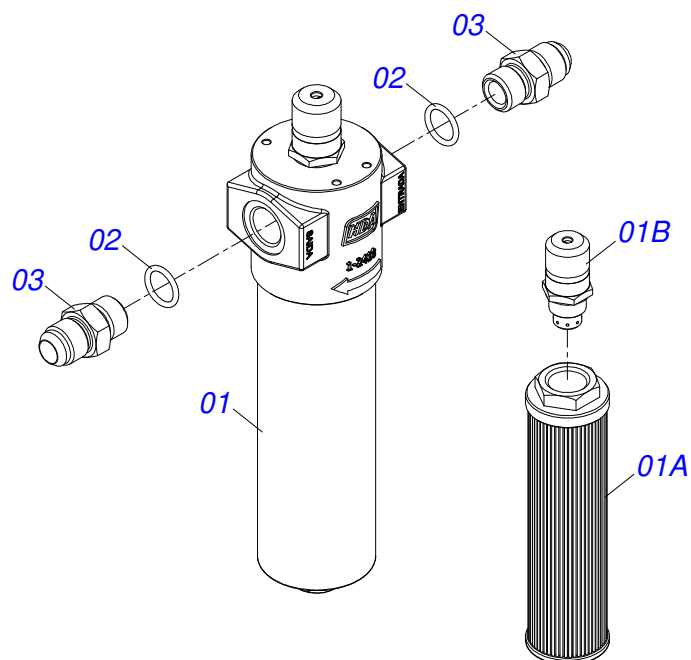

Item	Code	Description	See page	QT
01	0503063077	PRESSURE FILTER PARKER HDA FP20 10FV 06B LV6		01
01A	0503035357	FILTERING ELEMENT FOR PRESSURE FILTER		01
01B	0503019963	DIRT PRESSURE LINE INDICATOR		01
02	0503010605	O'RING		02
03	0591012696	NIPPLE 3/4 BSP X 1.1/16 UNF		02

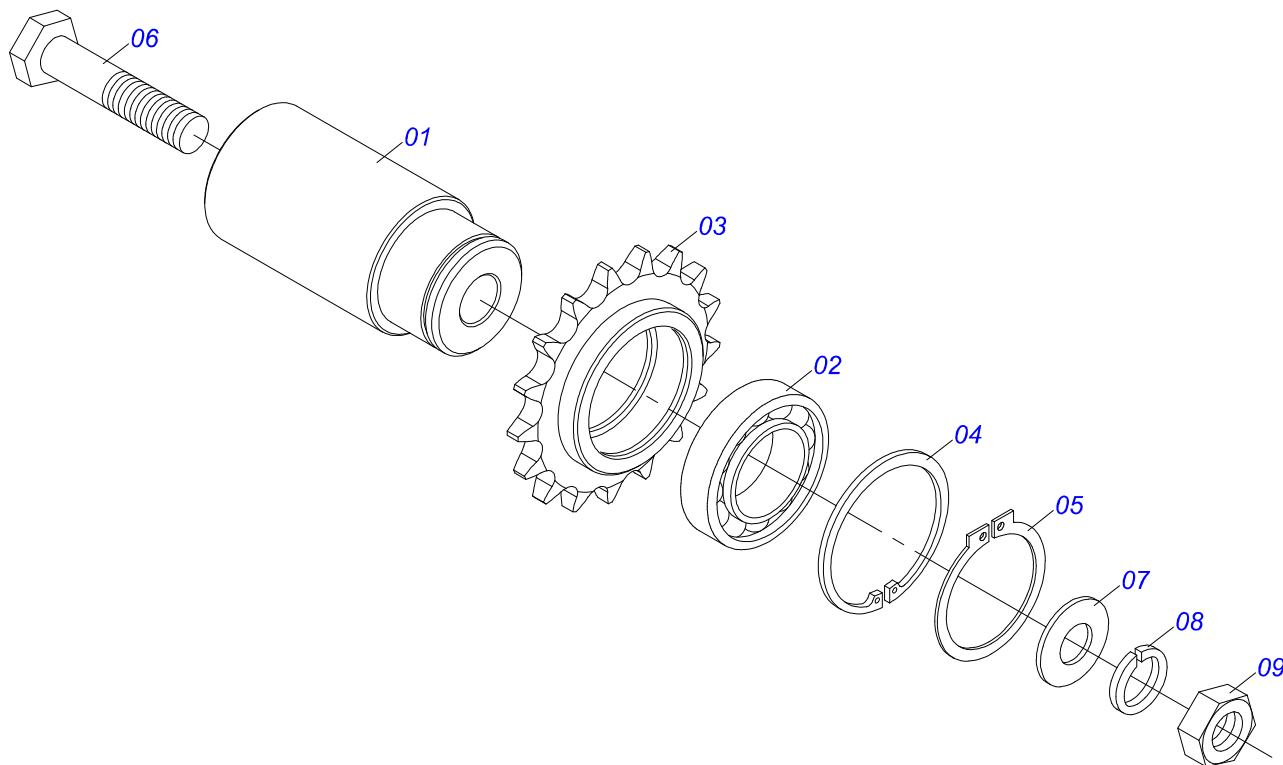

Item	Code	Description	See page	QT
01	0571015186	AXLE TIGHTENER 26		01
02	0503011410	ROLLER BEARING		01
03	0511061836	17Z GEAR		01
04	0503011105	SEAL RING		01
05	0503010406	501025 CLAMPING RING (FOR AXLE)		01
06	0503010718	3/8" X 3-1/2" BOLT		01
07	0501010984	10,50 X 27 X 3,00 FLAT WASHER		01
08	0503010025	3/8 SPRING WASHER		01
09	0503010026	3/8" NUT		01

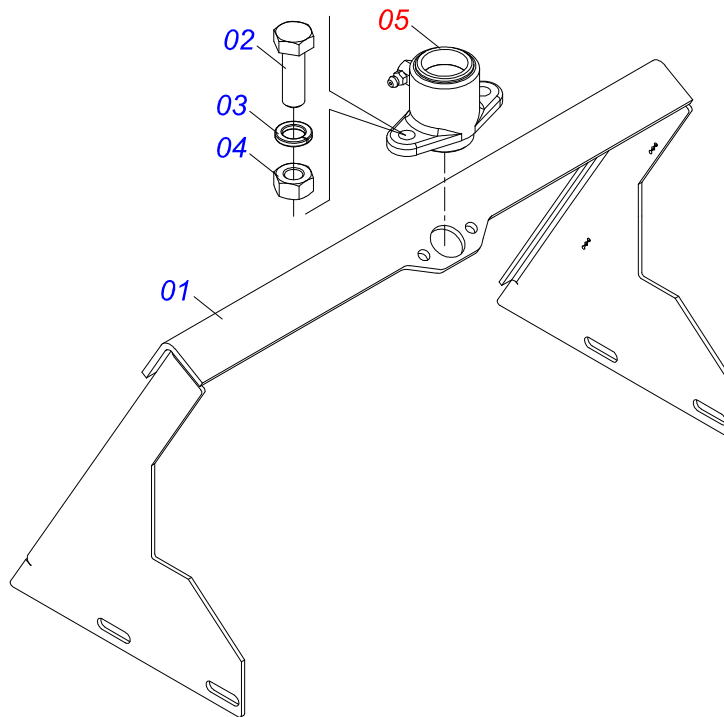

Item	Code	Description	See page	QT
01	0501069841	SLUICE VALVE SUPPORT		01
02	0503010371	5/16" X 1" BOLT		02
03	0503011444	SPRING WASHER		02
04	0503010337	5/16" NUT		02
05	0511059094	SHAFT BEARING THREADED	15	01

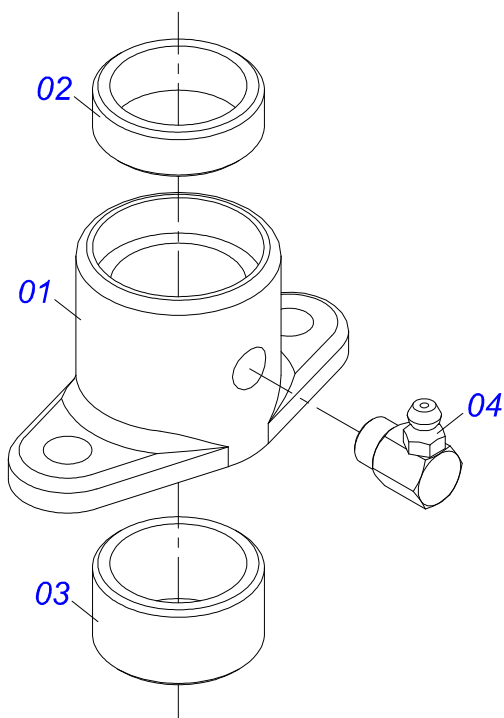

Item	Code	Description	See page	QT
01	0502010581	ROD BEARING		01
02	0521010458	SLEEVE		01
03	0521010457	SLEEVE		01
04	0503010004	1890 GREASE FITTING		01

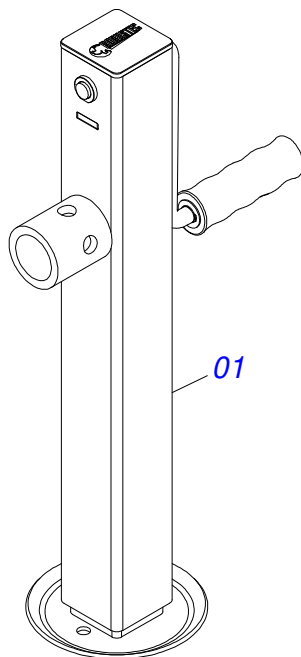

Item	Code	Description	See page	QT
01	0503062157	DRAWBAR JACK	16	01

ASSY LADDER

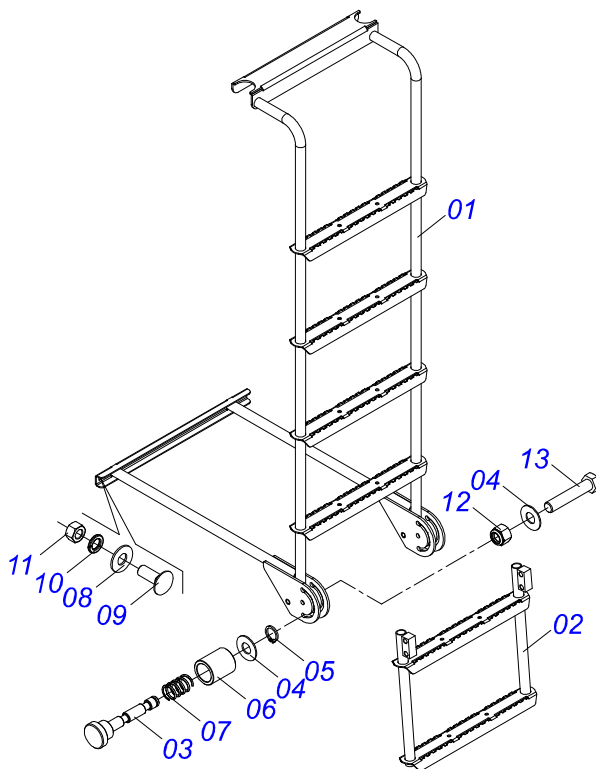

Item	Code	Description	See page	QT
01	0521067154	LADDER		01
02	0521067130	LADDER EXTENDER		01
03	0571019930	EXTENSION LOCK AXLE		01
04	0501013519	FLAT WASHER		03
05	0503010291	501012 CLAMPING RING (FOR AXLE)		01
06	0571019931	GUIDE GLOVE		01
07	0503032035	0.7" X 1.2" X 1" COMPRESSION SPRING		01
08	0501013518	FLAT WASHER		02
09	0501011643	3/8 X 1" BOLT		02
10	0503010025	3/8 SPRING WASHER		02
11	0503010026	3/8" NUT		02
12	0503010589	1/2" UNC SELF ADJUSTING NUT		02
13	0503010734	1/2" X 2-1/2" BOLT		02

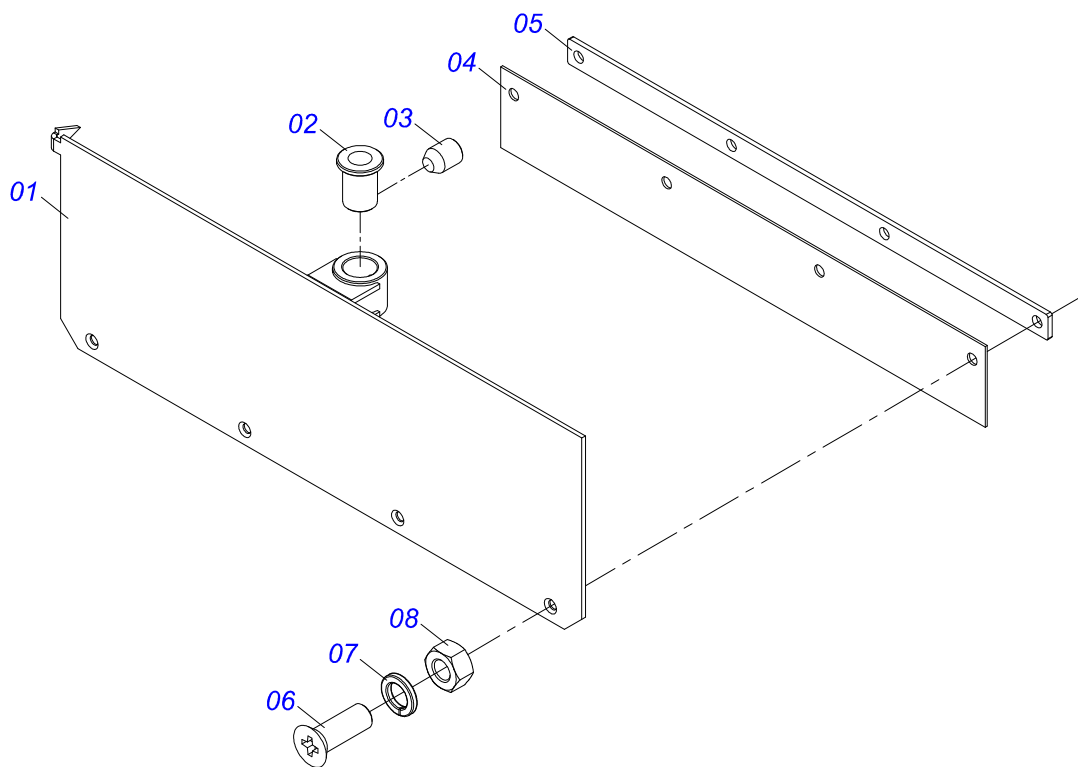

Item	Code	Description	See page	QT
01	0501069181	SLUICE VALVE COVER		01
02	0501019831	ADJUSTING NUT		01
03	0503011148	3/8" X 1/2" BOLT		01
04	0511014562	PROTECTION SMALLER		01
05	0511016575	RUBBER COVER FIXER		01
06	0503010546	5/16" X 7/8" BOLT		04
07	0503011444	SPRING WASHER		04
08	0503010337	5/16" NUT		04

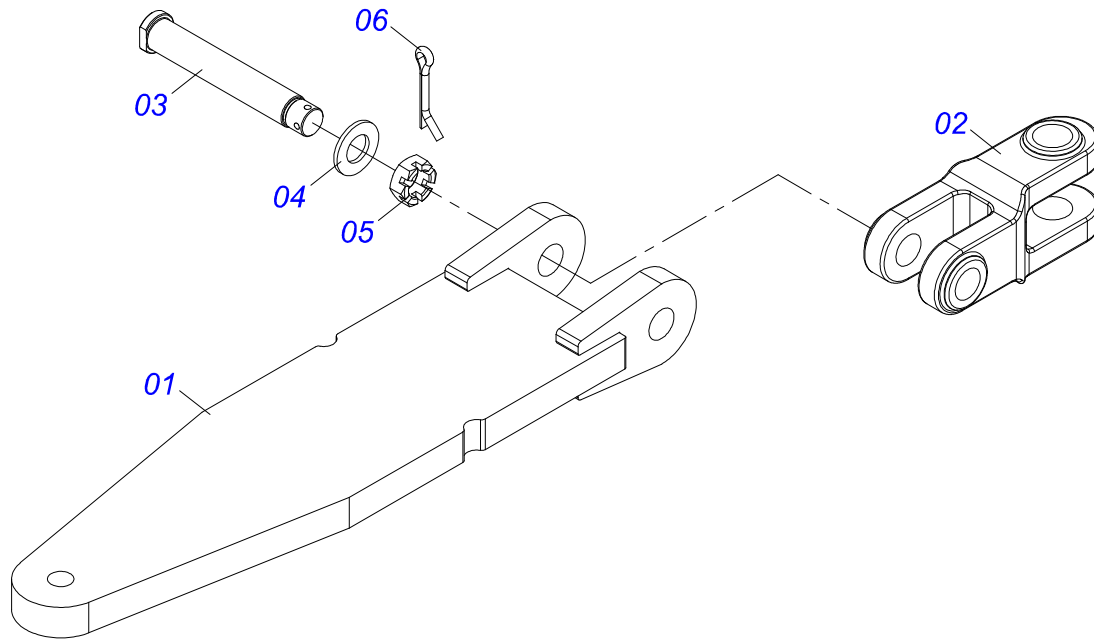

Item	Code	Description	See page	QT
01	0511066154	SEMI COUPLING		01
02	1902040330	TRACTOR HITCH		01
03	0541014957	PIN DRAG		01
04	0501017779	32 X 60 X 4.75 FLAT WASHER		01
05	0503011052	1.1/4" X 0.77" CASTLE NUT		01
06	0503010010	1/4" X 2.1/2" COTTERPIN		01



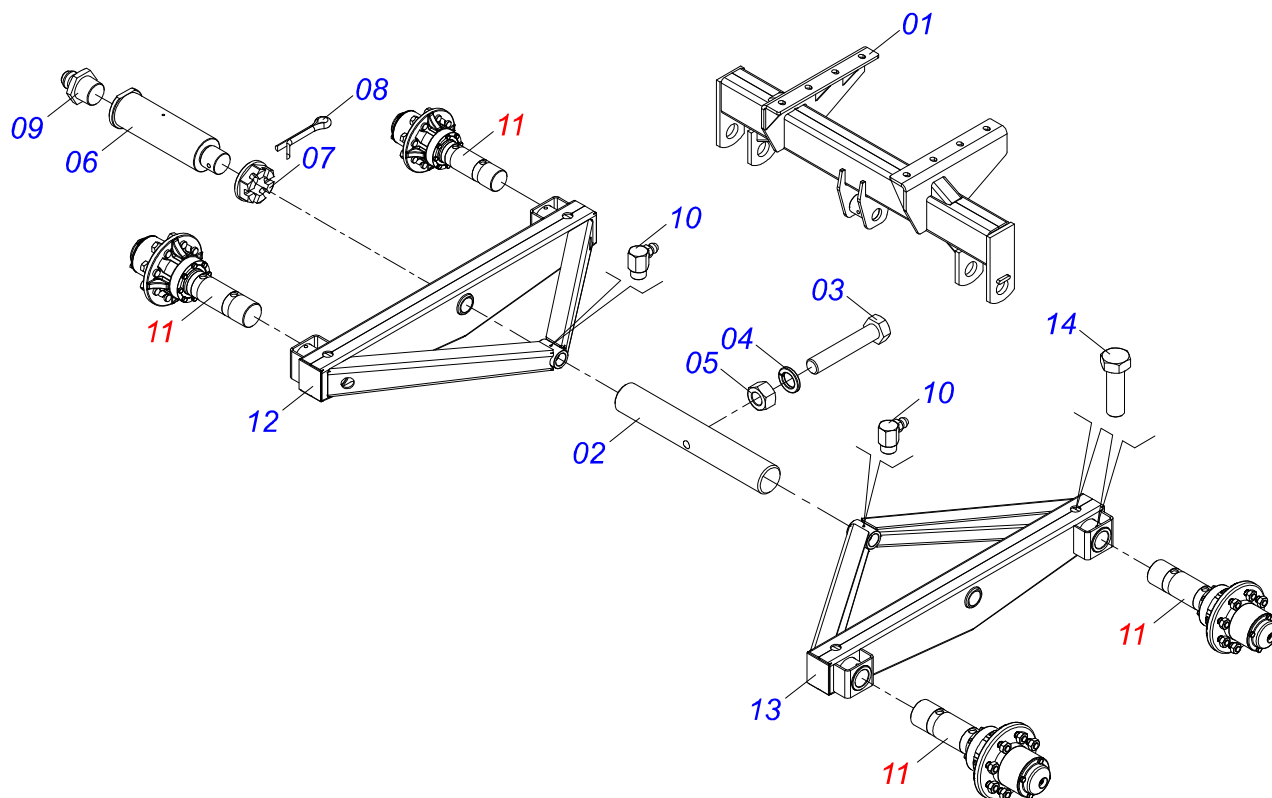

Item	Code	Description	See page	QT
01	0511065192	BEEL CRANK FIXER SUPPORT		01
02	0531016579	CENTRAL AXLE		01
03	0503010547	1/2" X 4" BOLT		01
04	0503011440	SPRING WASHER		01
05	0503010060	1/2 UNC G.5 ZN HEX NUT		01
06	0521069954	COUPLING SHAFT 60,10 X 183		02
07	0501011301	1.1/2 UNC 6FPP 2.5/16 NUT		02
08	0503010010	1/4" X 2.1/2" COTTERPIN		02
09	0503010002	1800 GREASE FITTING		02
10	0503010004	1890 GREASE FITTING		02
11	0501056347	CARRYING WHEELS WITHOUT TIRE	21	04
12	0511066146	LEFT ROCKER ARM		01
13	0511066145	RIGHT ROCKER ARM		01
14	0501810100	BOLT 5/8 UNC X 2		08

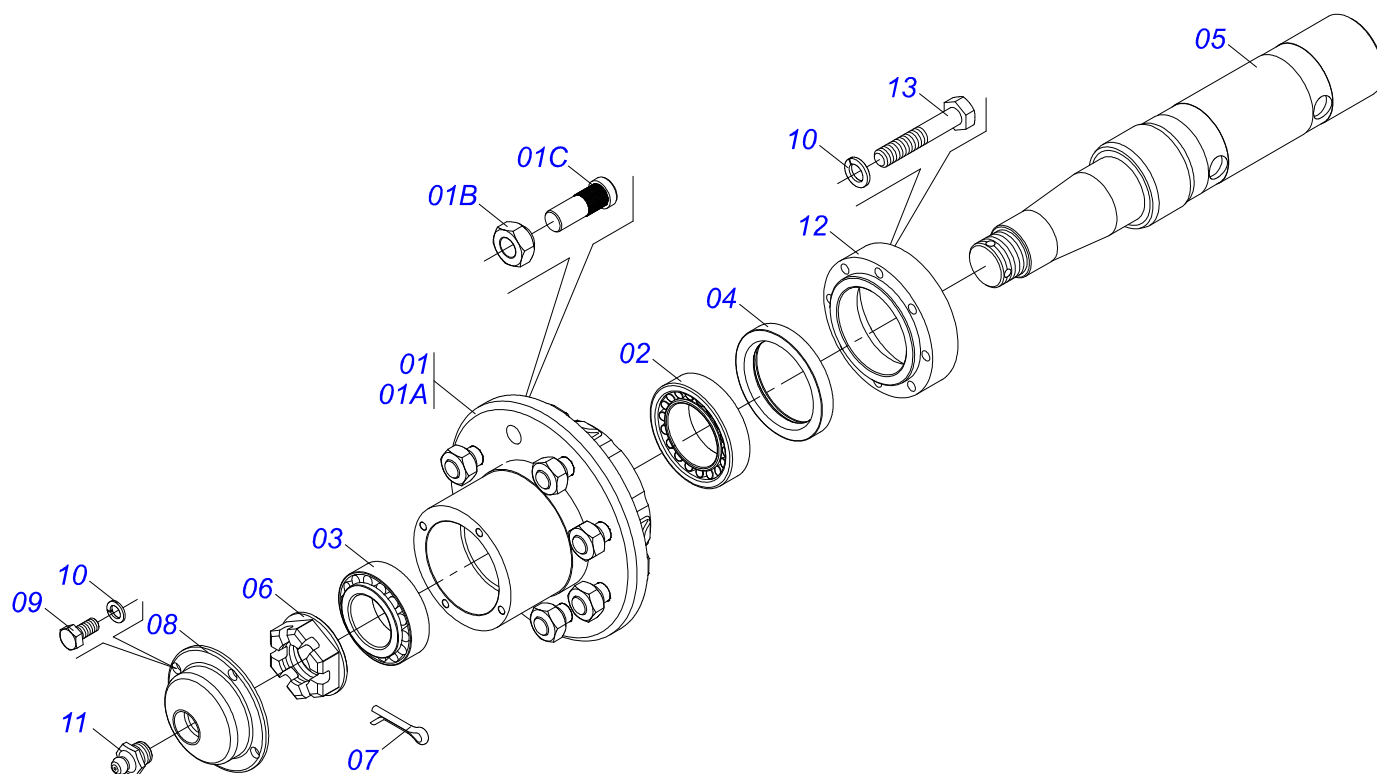

Item	Code	Description	See page	QT
01	0501110763	CARRYING WHEEL HUB		01
01A	0502012318	CARRYING WHEEL HUB		01
01B	0503010064	5/8 UNF CONIC NUT		08
01C	0501011052	5/8" X 1-3/4" BOLT		08
02	0503013453	SKF 33011 ROLLER BEARING		01
03	0503013454	SKF 33109 ROLLER BEARING		01
04	0503010086	SEAL 0009B-B		01
05	0541015586	WHEEL AXLE		01
06	0501010630	1.1/2" CASTLE NUT		01
07	0503010523	1/4" X 2" COTTERPIN		01
08	0502020592	COVER		01
09	0503010295	SCREW 5/16 UNC X 5/8 CS G.2 ZN		04
10	0503011444	SPRING WASHER		12
11	0503010002	1800 GREASE FITTING		01
12	0502012175	SEAL FLANGE		01
13	0503010397	5/16" X 1-3/4" BOLT		08

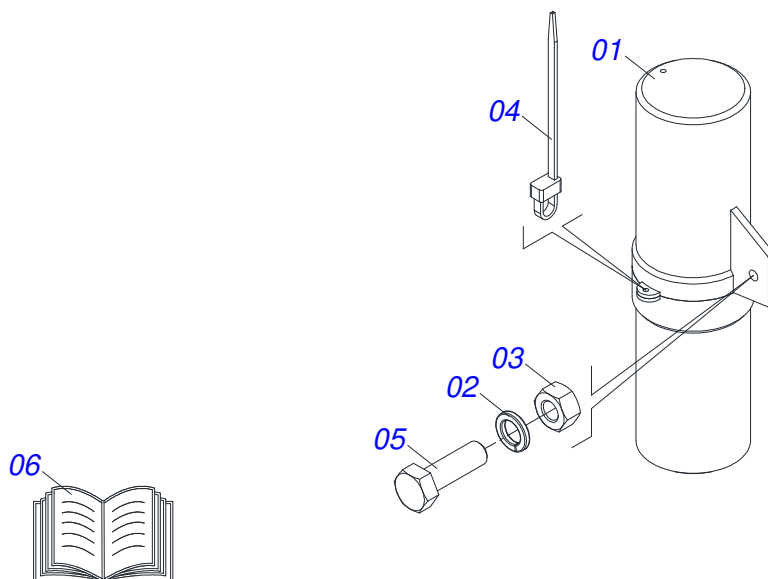

Item	Code	Description	See page	QT
01	0503060100	INSTRUCTIONS MANUAL CANISTER		01
02	0503010179	LOCK WASHER 5/16 ZN 1K01528		01
03	0503010337	5/16" NUT		01
04	0503010267	NYLON CLAMP		01
05	0503010363	BOLT 5/16 UNC X 1 C S G.2 ZN		01
06	0501032417	BAG WITH INSTRUCTION MANUAL/CATALOG		01

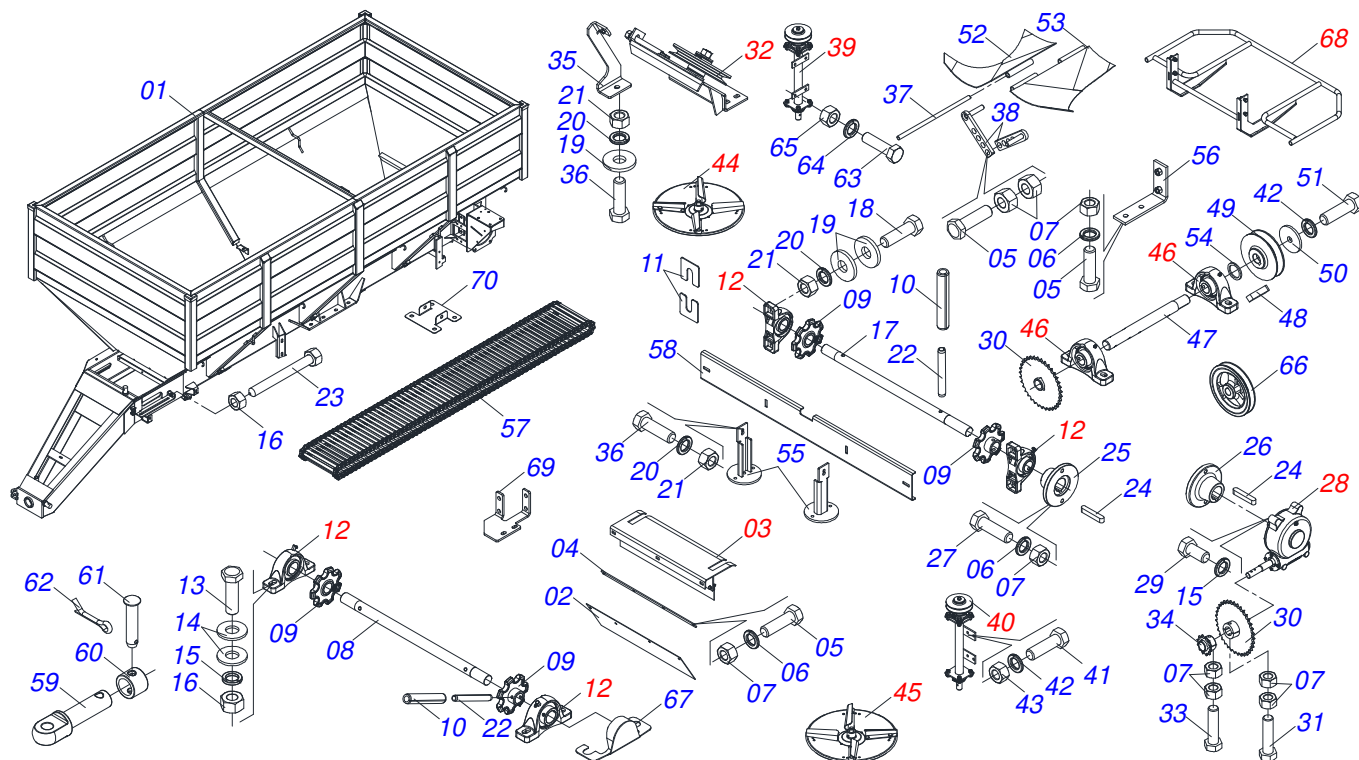

Item	Code	Description	See page	QT
01	0511064672	DCA2 10500 MC BUCKET		01
02	0511011866	PROTECTION LARGER		01
03	0511059305	REAR PROTECTION WITH MINOR PROTECTOR	24	01
04	0511016575	RUBBER COVER FIXER		01
05	0503010237	3/8" X 1" BOLT		06
06	0503011443	3/8" SPRING WASHER		08
07	0503010026	3/8" NUT		16
08	0511016482	DRIVEN AXLE		01
09	0502040728	7Z GEAR		04
10	0503010361	SPRING PIN		06
11	0501010794	HIDR CHOCK REGULATOR		04
12	0501044308	AGRICULTURAL BEARING ASSY	25	04
13	0503010233	5/8" X 2-1/2" BOLT		04
14	0501012140	FLAT WASHER		08
15	0503011445	SPRING WASHER		08
16	0503010013	5/8 NUT		06
17	0511016481	MOTOR SHAFT		01
18	0503010740	BOLT 1/2 UNC X 2 CS G.5 ZN		12
19	0511017302	FLAT WASHER 13,50 X 32,50 X 3,0 ZN		27
20	0503011440	SPRING WASHER		21
21	0503010060	1/2 UNC G.5 ZN HEX NUT		21
22	0503010756	0.2" X 2.4" SPRING PIN		04
23	0501067853	ROD STABILIZER		02
24	0501010540	KEYWAY SQUARE		02
25	0511016540	MAT COUPLING FLANGE		01
26	0511016541	REDUCTION COUPLING FLANGE		01
27	0503010849	3/8" X 1-1/2" BOLT		03
28	0501047985	REDUCER	26	01
29	0503011167	M16 X 2 X 30 BOLT		04
30	0501069020	35Z GEAR		02
31	0503011141	3/8" X 2-3/4" BOLT		02



**DCA2 10500 MC WITH HYDRAULIC DRIVE  
FRAME WITH BUCKET SEMI MOUNTED**

Item	Code	Description	See page	QT
32	0501046802	BELT TENSIONER ASSY	28	01
33	0503011268	3/8" X 2-1/2" BOLT		01
34	0501069017	12Z GEAR		01
35	0511060909	PROTECTION REAR SUPPORT FIXER		01
36	0503010920	1/2 UNC X 1.1/2 C S G.5 ZN BOLT		09
37	0511016530	TENSIONER OPEN		01
38	0501067368	DIVISOR REGULATOR OPEN		02
39	0501051782	RIGHT BEARING SUPPORT DISC	29	01
40	0501051783	LEFT BEARING SUPPORT DISC	30	01
41	0503010920	1/2 UNC X 1.1/2 C S G.5 ZN BOLT		12
42	0503011440	SPRING WASHER		13
43	0503010060	1/2 UNC G.5 ZN HEX NUT		12
44	0501051972	DISTRIBUTOR RIGHT DISC ASSY	32	01
45	0501051973	DISTRIBUTOR LEFT DISC ASSY	33	01
46	0511041213	AGRICULTURAL BEARING	34	04
47	0521011063	TRANSMISSION AXLE		01
48	0501010536	KEYWAY SQUARE		01
49	0502011361	REEL 1C 5.5" X 1.1" PULLEY		01
50	0511014052	FLAT WASHER		01
51	0503010355	7/16" X 1" BOLT		01
52	0501067203	RIGHT FLOW DIVIDING		01
53	0501067361	LEFT FLOW DIVIDING		01
54	0511016579	WASHER		01
55	0521067015	SUPPORT PROTETION DISC		02
56	0501069225	BELT PROTECTION FIXER		01
57	0511064673	DRIVE THE FERTILIZER TRANSPORT		01
58	0501019838	BAMPER		01
59	1902040223	PIN HITCH		01
60	1902040327	LOCK SLEEVE		01
61	0521010579	COUPLING SHAFT		01
62	0503010571	1/4" X 1.1/2 COTTERPIN		01
63	0503010920	1/2 UNC X 1.1/2 C S G.5 ZN BOLT		04
64	0503010019	1/2" SPRING WASHER		04
65	0503010060	1/2 UNC G.5 ZN HEX NUT		04
66	0502012936	1 C X 219 X 30 PULLEY		01
67	0521068822	BEARING PROTECTION		03
68	0531050244	PROTECTOR DISC	35	01
69	0591016143	FIXER SUPPORT BELT PROTECTION		01
70	0591016132	FIXER BODY PROTECTION COVER		01

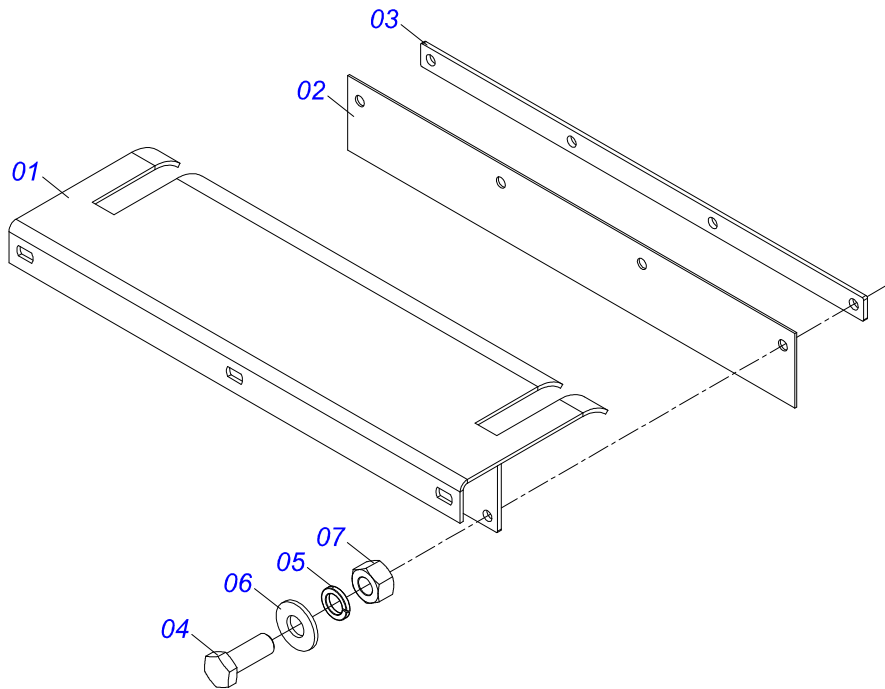

Item	Code	Description	See page	QT
01	0501067379	MAT REAR PROTECTION		01
02	0511014562	PROTECTION SMALLER		01
03	0511016575	RUBBER COVER FIXER		01
04	0503010237	3/8" X 1" BOLT		04
05	0503011443	3/8" SPRING WASHER		04
06	0501010984	10,50 X 27 X 3,00 FLAT WASHER		04
07	0503010026	3/8" NUT		04

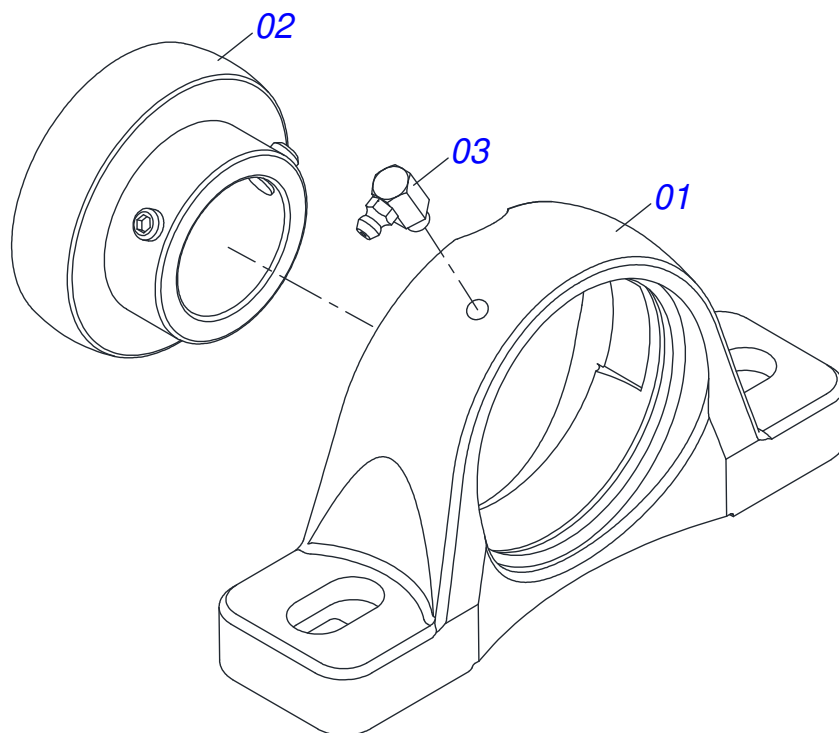

Item	Code	Description	See page	QT
01	0502011050	AGRICULTURAL HOUSING BEARING		01
02	0503011163	1108/UCR BEARING ASSY		01
03	0503010004	1890 GREASE FITTING		01

REDUCER

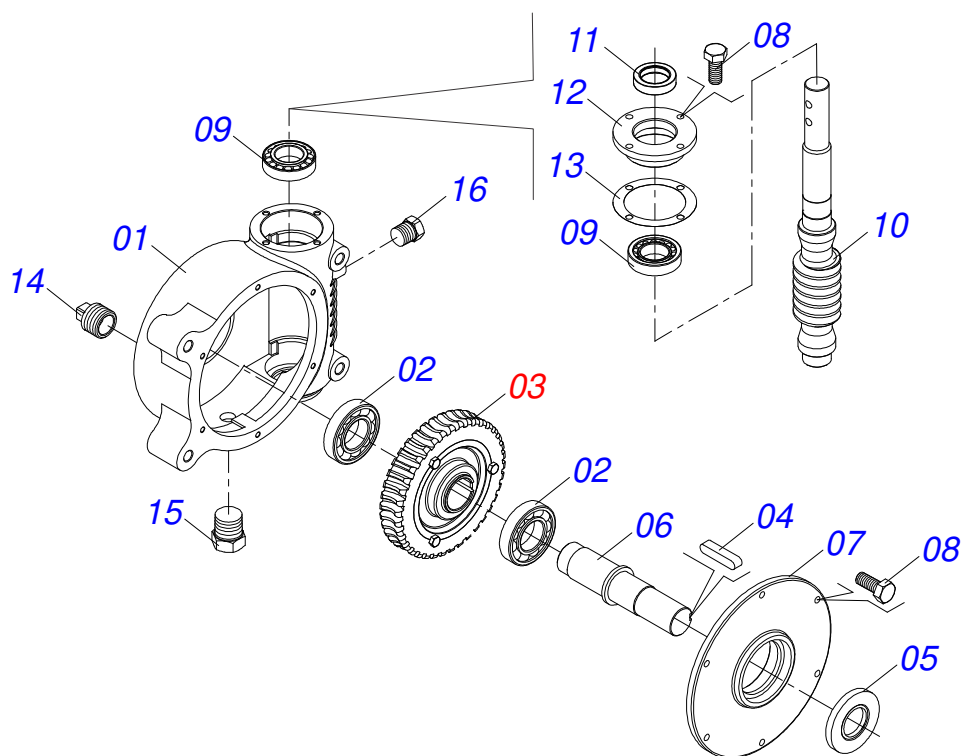

Item	Code	Description	See page	QT
01	0502011456	REDUCTION BOX		01
02	0503011095	6208 BALL BEARING		02
03	0501051774	38Z CROWN	27	01
04	0503011304	1/2" X 2.4" KEYWAY SQUARE		01
05	0503010818	02675-BRG SEAL		01
06	0521010996	AXLE		01
07	0502020556	LARGER COVER		01
08	0503010240	BOLT		10
09	0503010016	BEARING LM		02
10	0521010997	SCREW THEAD		01
11	0503011171	00912-BRG SEAL		01
12	0502011457	SMALLER COVER		01
13	0503030981	102 X 75,5 X 0,10 JOINT		01
14	0521011023	PLUG		01
15	0513010009	LEVEL DISPLAY		01
16	0503010856	OIL PLUG		01



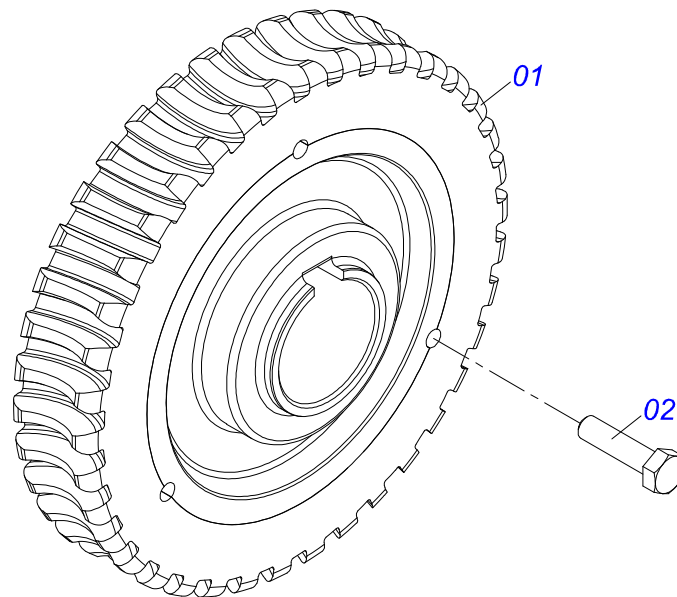

Item	Code	Description	See page	QT
01	0501110280	38Z CONICAL		01
02	0503010365	BOLT 5/16 UNC X 1.1/4 C S G.5 ZN		03

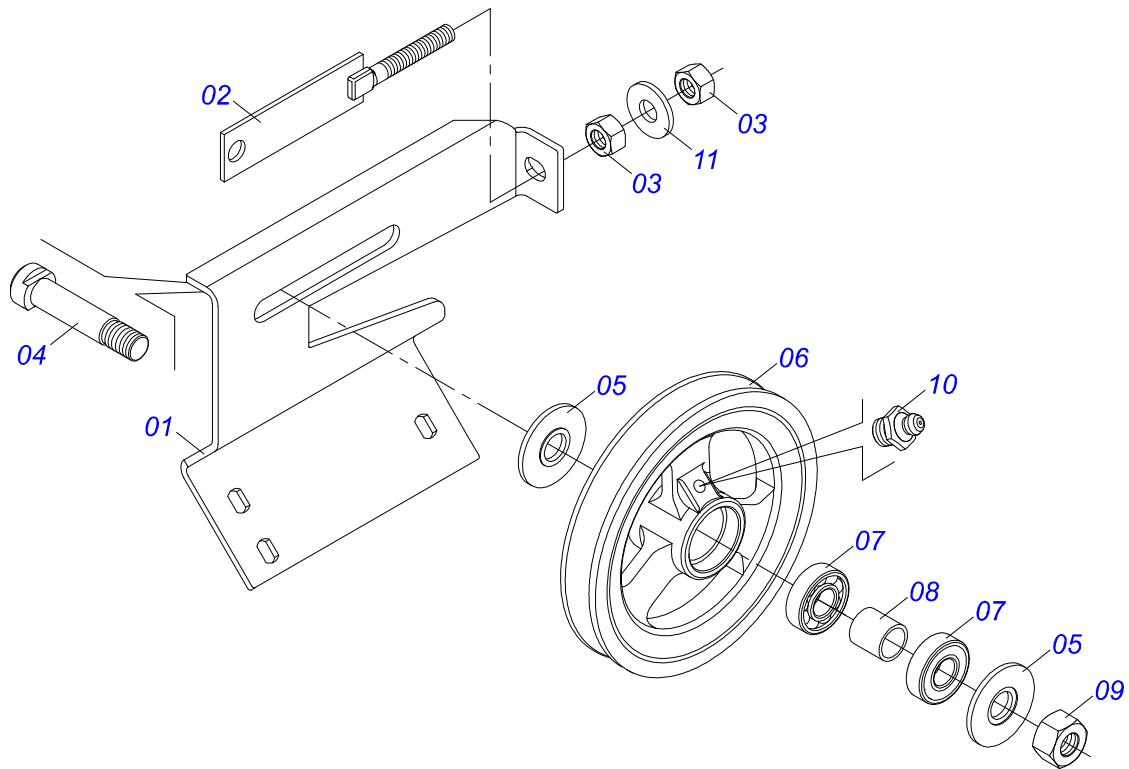

Item	Code	Description	See page	QT
01	0501066100	SUPPORT		01
02	0501065968	1C X 8.3 PULLEY TENSIONER		01
03	0503010013	5/8 NUT		02
04	0511012362	TIGHTENER AXLE PULLEY		01
05	0501019288	WASHER SPACER		02
06	0502011366	REEL 1C 8.3" X 1.6" PULLEY		01
07	0503010690	6204 BALL BEARING		02
08	0521010497	0.8" X 1.1" X 1.1" SPACER		01
09	0503010014	3/4" HEX NUT		01
10	0503010002	1800 GREASE FITTING		01
11	0501012140	FLAT WASHER		01

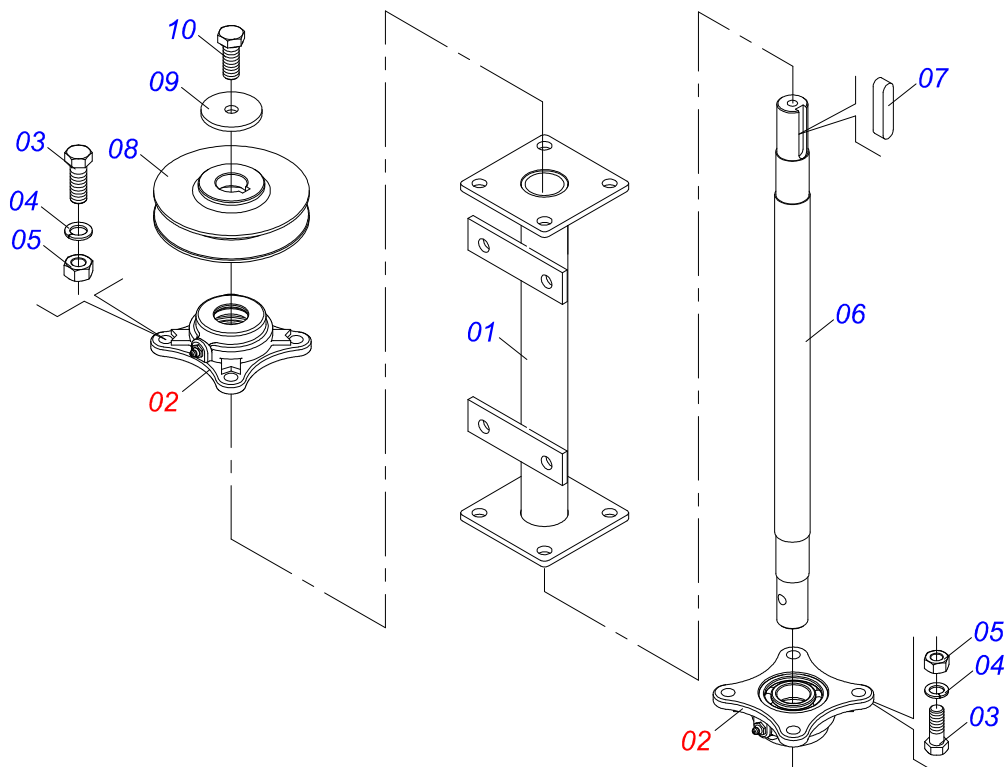

Item	Code	Description	See page	QT
01	0501067387	DISTRIBUTOR RIGHT SUPPORT DISC		01
02	0501048000	AGRICULTURAL BEARING	31	02
03	0503011102	BOLT 7/16 UNC X 1.1/4 C S G.5 ZN		08
04	0503011446	SPRING WASHER		08
05	0503010244	7/16" NUT		08
06	0511016489	DISTRIBUTOR AXLE CONDUCTOR DISC		01
07	0501010536	KEYWAY SQUARE		01
08	0502011361	REEL 1C 5.5" X 1.1" PULLEY		01
09	0511014052	FLAT WASHER		01
10	0503010355	7/16" X 1" BOLT		01

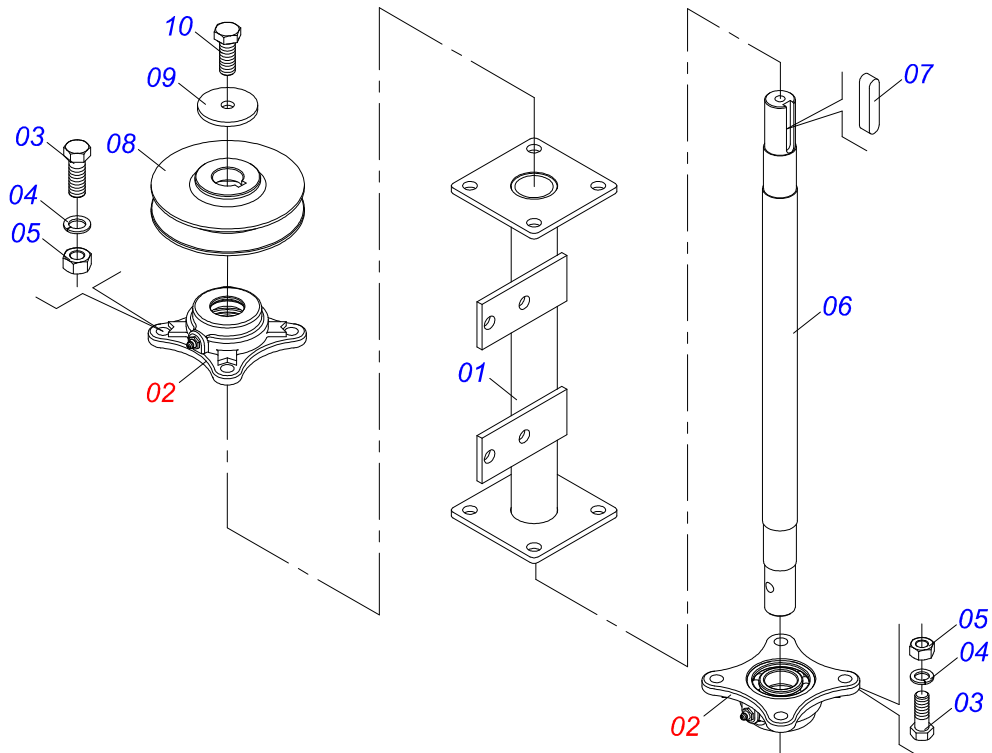

Item	Code	Description	See page	QT
01	0501067388	DISTRIBUTOR LEFT SUPPORT DISC		01
02	0501048000	AGRICULTURAL BEARING	31	02
03	0503011102	BOLT 7/16 UNC X 1.1/4 C S G.5 ZN		08
04	0503011446	SPRING WASHER		08
05	0503010244	7/16" NUT		08
06	0511016489	DISTRIBUTOR AXLE CONDUCTOR DISC		01
07	0501010536	KEYWAY SQUARE		01
08	0502011361	REEL 1C 5.5" X 1.1" PULLEY		01
09	0511014052	FLAT WASHER		01
10	0503010355	7/16" X 1" BOLT		01

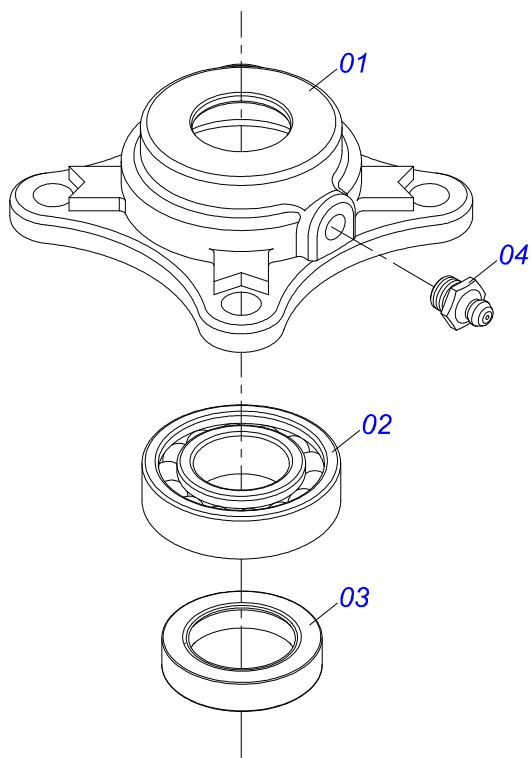

Item	Code	Description	See page	QT
01	0502011442	AGRICULTURAL HOUSING BEARING		01
02	0503010276	6206 BALL BEARING		01
03	0503011865	SEAL		01
04	0503010002	1800 GREASE FITTING		01

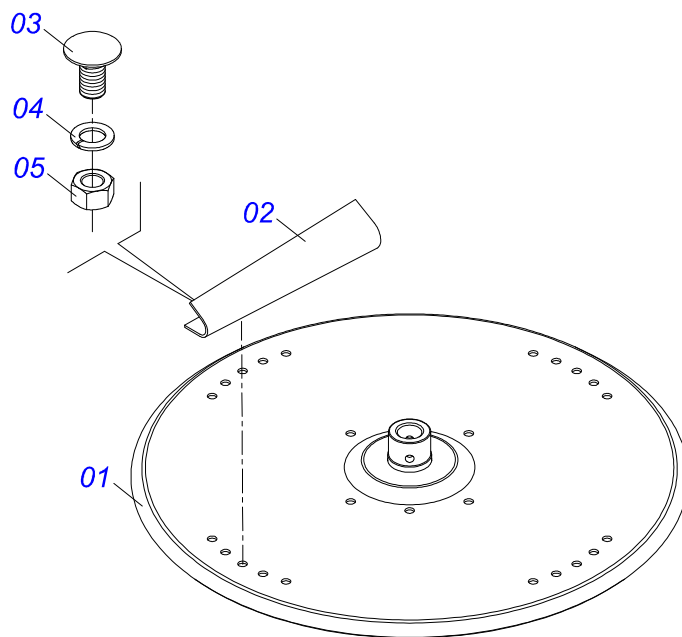

Item	Code	Description	See page	QT
01	0501069605	DISTRIBUTOR DISC		01
02	0521018638	LH FLIP		04
03	0503013029	3/8" X 3/4" BOLT		08
04	0503011443	3/8" SPRING WASHER		08
05	0503010026	3/8" NUT		08

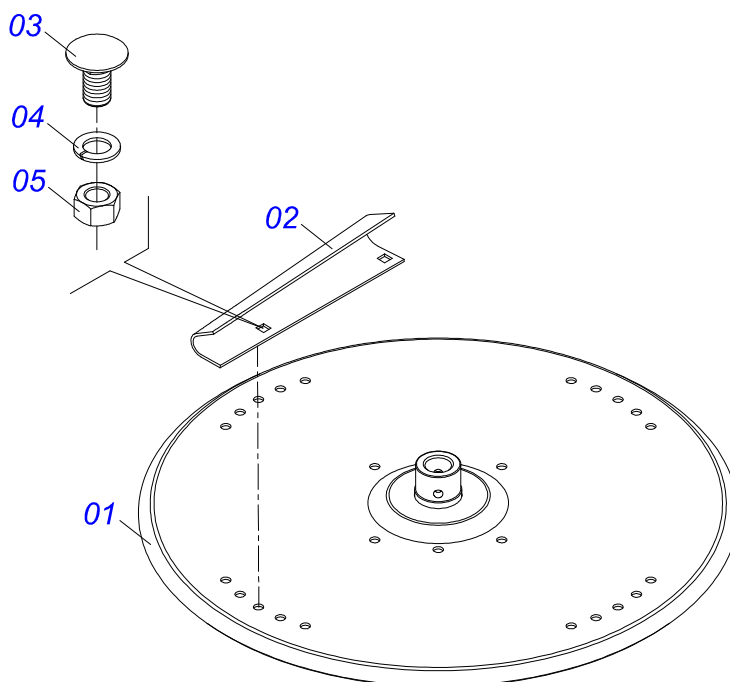

Item	Code	Description	See page	QT
01	0501069605	DISTRIBUTOR DISC		01
02	0521018637	LEFT FLIP		04
03	0503013029	3/8" X 3/4" BOLT		08
04	0503011443	3/8" SPRING WASHER		08
05	0503010026	3/8" NUT		08

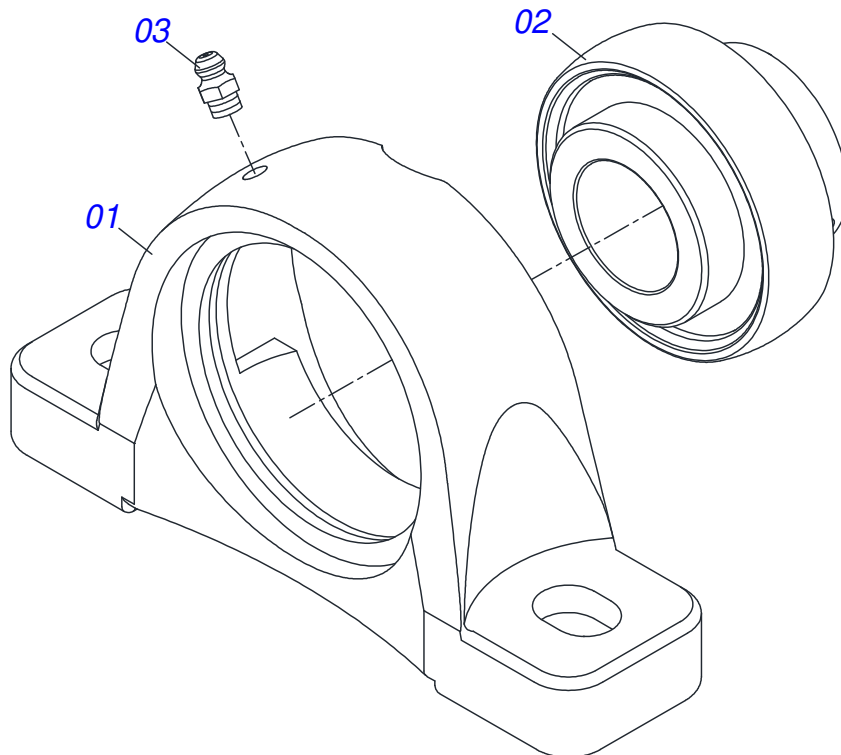

Item	Code	Description	See page	QT
01	0502011954	AGRICULTURAL HOUSING BEARING		01
02	0503011884	BALL BEARING		01
03	0503010691	1/4" GREASE FITTING		01



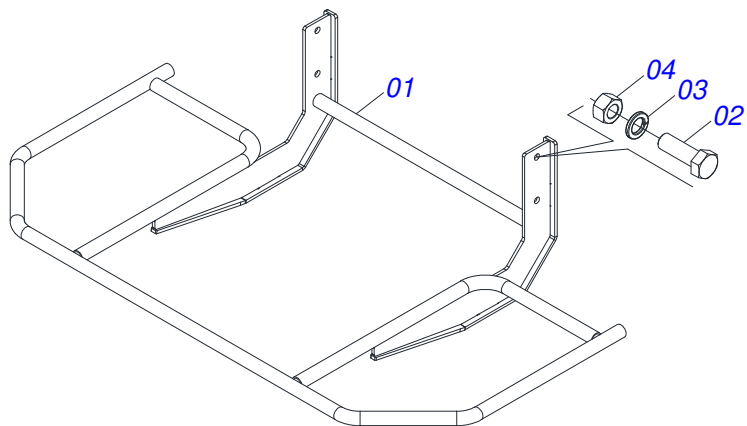

Item	Code	Description	See page	QT
01	0531061810	DISC PROTECTION		01
02	0503010920	1/2 UNC X 1.1/2 C S G.5 ZN BOLT		04
03	0503011440	SPRING WASHER		04
04	0503010060	1/2 UNC G.5 ZN HEX NUT		04

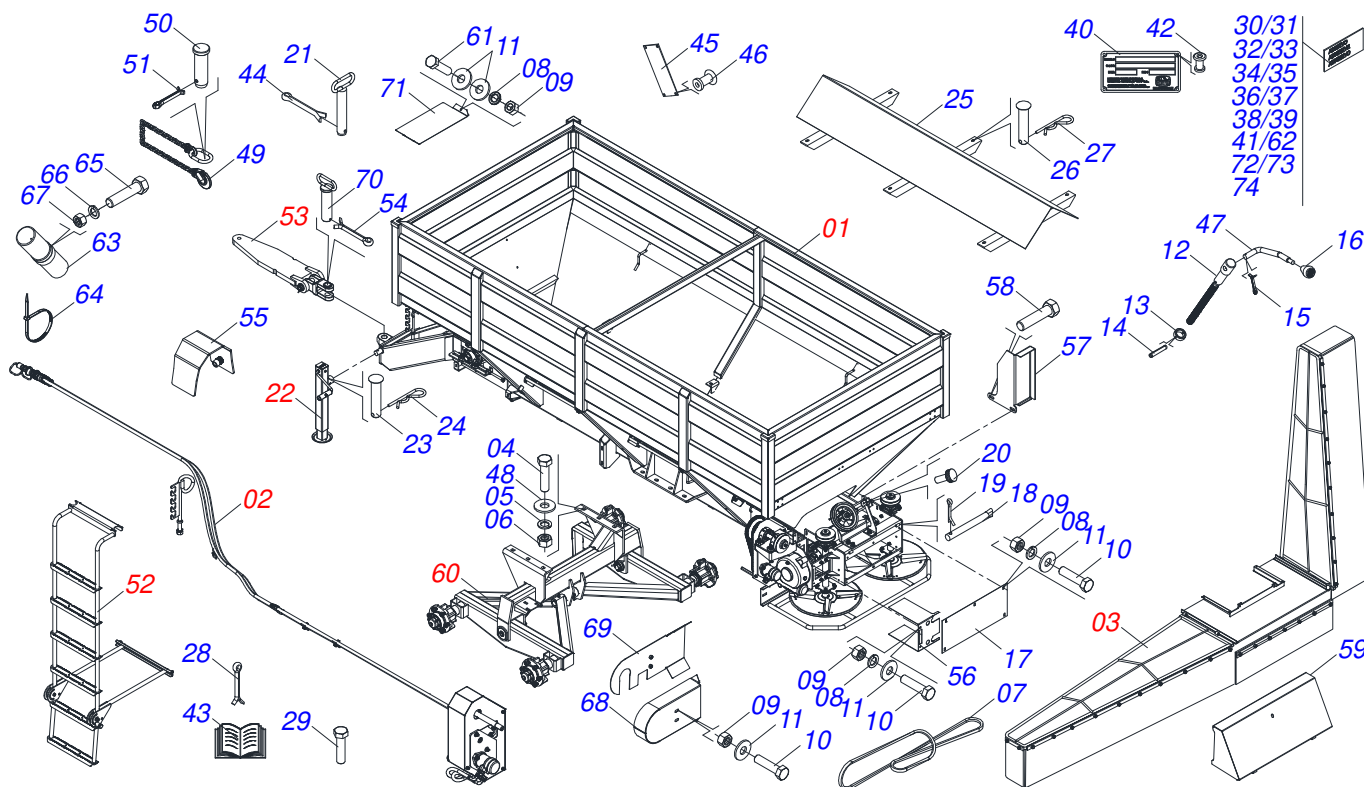

Item	Code	Description	See page	QT
01	0521050038	FRAME WITH BUCKET SEMI MOUNTED	23	01
02	0511056261	HYDRAULIC DRIVE ASSY	37	01
03	0531052379	DAMPER ASSY	38	01
04	0501010125	3/4" X 2-1/2" BOLT		08
05	0503010023	3/4" SPRING WASHER		08
06	0503010014	3/4" HEX NUT		06
07	0503010154	C-128 BELT		01
08	0503010025	3/8 SPRING WASHER		14
09	0503010026	3/8" NUT		12
10	0503010237	3/8" X 1" BOLT		12
11	0501010984	10,50 X 27 X 3,00 FLAT WASHER		15
12	0561014861	REGULATOR		01
13	0511013015	SLEEVE		01
14	0503010561	SPRING PIN		01
15	0503010257	1/8" X 1" COTTERPIN		01
16	0503030878	LEVER CRANK		01
17	0501019460	REAR PROTECTION		01
18	0501017574	0.3" X 2.7" AXLE		02
19	0503010140	1/8" X 3/4" COTTERPIN		02
20	0503010386	CABLE		01
21	0501069080	COUPLING SHAFT		01
22	0503062157	DRAWBAR JACK	16	01
23	0521010549	COUPLING SHAFT		01
24	0503030168	HITCH PIN CLIP		01
25	0511064692	DEFLECTOR		01
26	0521017623	0.5" X 1.5" COUPLING SHAFT		06
27	0503030168	HITCH PIN CLIP		06
28	0503010131	3/16" X 1-1/2" COTTERPIN		04
29	0503010751	C3/8" X 1.1/4" HEX BOLT G.5		04
30	0503034392	ADHESIVE LABEL		04
31	0503034393	ADHESIVE LABEL		02



## ASSY FRAME

0521046819

Item	Code	Description	See page	QT
32	0503034394	ADHESIVE LABEL		02
33	0503034395	ADHESIVE LABEL		02
34	0503031809	ADHESIVE LABEL		01
35	0503031818	ADHESIVE LABEL		01
36	0503031859	ADHESIVE LABEL DANGER		02
37	0503031827	LUBRICATE AND RETIGHTEN DAILY DECAL		01
38	0503031428	READ MANUAL DECAL		01
39	0503031087	ADHESIVE LABEL		01
40	0503030310	ADHESIVE		01
41	0503032949	ADHESIVE LABEL		01
42	0503010001	3.2 X 5.5 RIVET		04
43	0501032417	BAG WITH INSTRUCTION MANUAL/CATALOG		01
44	0503010534	3/8 X 2-1/2 COTTERPIN		01
45	0503030751	REGULATOR PLATE		01
46	0503012209	RIVET POP		04
47	0521011107	CRANK BODY		01
48	0501010322	FLAT WASHER		16
49	0503013150	1300 X 3/8 CHAIN		01
50	0581011220	COUPLING SHAFT		01
51	0503010131	3/16" X 1-1/2" COTTERPIN		01
52	0511059633	ASSY LADDER	17	01
53	0511059024	ENGATE TRATOR COMPLETO	19	01
54	0503010010	1/4" X 2.1/2" COTTERPIN		01
55	0521068819	PULLEY AXLE PROTECTION		01
56	0581017497	COUPLING PROTECTION		01
57	0581017492	SIDE PROTECTION BELT		01
58	0503010849	3/8" X 1-1/2" BOLT		04
59	0501069840	REAR COVER PROTECTION		01
60	0511042281	BELL CRANK FIXER SUPPORT	20	01
61	0503010849	3/8" X 1-1/2" BOLT		02
62	0503034648	ADHESIVE LABEL		01
63	0503060100	INSTRUCTIONS MANUAL CANISTER		01
64	0503010267	NYLON CLAMP		01
65	0503010363	BOLT 5/16 UNC X 1 C S G.2 ZN		01
66	0503010179	LOCK WASHER 5/16 ZN 1K01528		01
67	0503010337	5/16" NUT		01
68	0581017500	REAR LATERAL PROTECTION BELT		01
69	0521068820	REAR LATERAL PROTECTION BELT		01
70	0511066176	HITCH PIN		01
71	0581017442	FRONT PROTECTION		01
72	0503035156	LABEL ADHESIVE		01
73	0503035157	ADHESIVE LABEL DISTRIBUTOR LIMESTONE		01
74	0503036144	MAXIMUM SPEED ADHESIVE LABEL		01

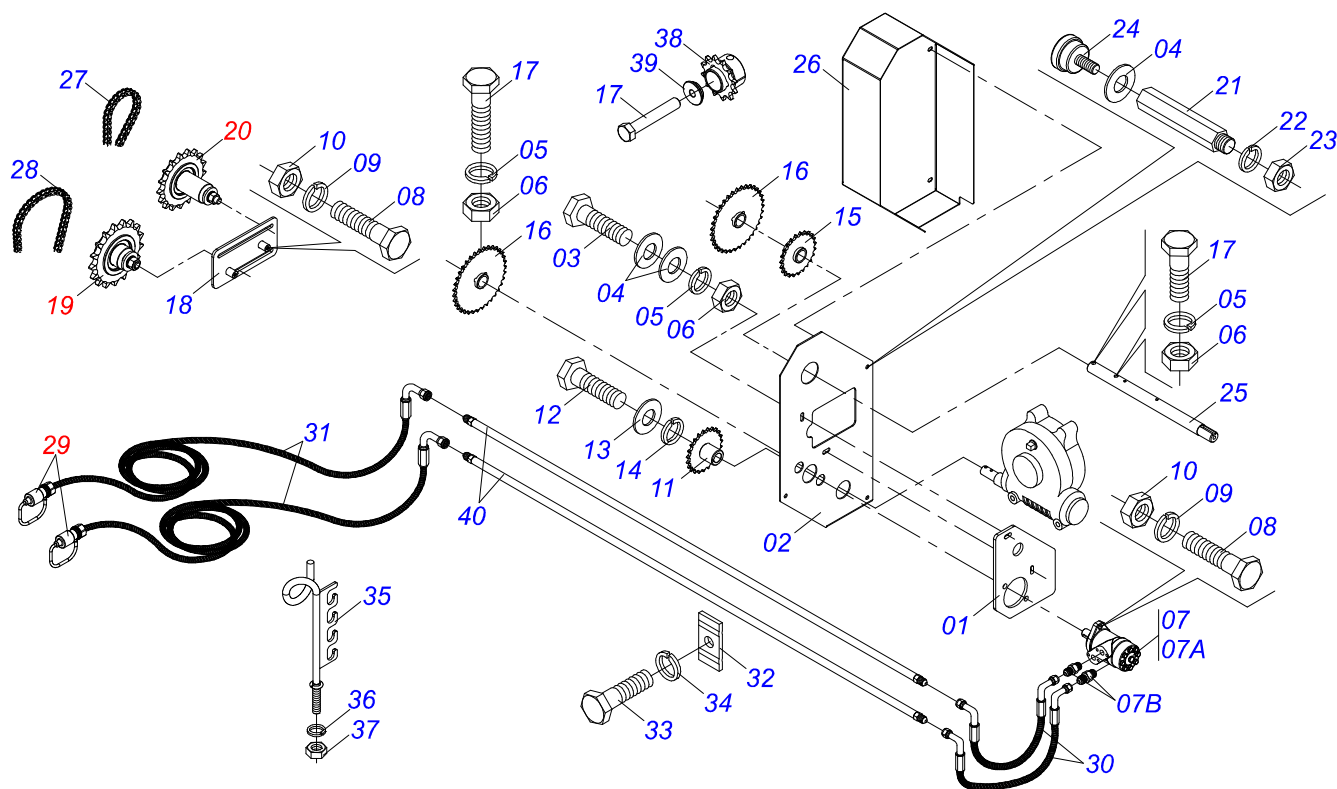

Item	Code	Description	See page	QT
01	0571015182	HIDRAULIC MOTOR SUPPORT		01
02	0571015447	PROTECTION REAR		01
03	0503010849	3/8" X 1-1/2" BOLT		04
04	0501010984	10,50 X 27 X 3,00 FLAT WASHER		07
05	0503011443	3/8" SPRING WASHER		05
06	0503010026	3/8" NUT		09
07	0511053588	MOTOR HYDRAULIC OMP 80 WITH NIPPLE 7/8 4 NIPPE 7/8		01
08	0503010920	1/2 UNC X 1.1/2 C S G.5 ZN BOLT		02
09	0503011440	SPRING WASHER		02
10	0503010060	1/2 UNC G.5 ZN HEX NUT		02
11	0521064566	GEAR HIDRAULIC MOTOR		01
12	0503011257	M 8 X 1,25 X 30 BOLT		01
13	0501010694	FLAT WASHER		01
14	0503011444	SPRING WASHER		01
15	0521063041	GEAR 23Z		01
16	0501069020	35Z GEAR		02
17	0503011141	3/8" X 2-3/4" BOLT		04
18	0521064691	SUPPORT TENSIONER		01
19	0511054496	TENSIONER SMALEER ASSY	5	01
20	0511054497	TENSIONER LARGER ASSY	13	01
21	0571015189	PRISONER 3/8"		03
22	0503010025	3/8 SPRING WASHER		03
23	0503010026	3/8" NUT		03
24	0503010386	CABLE		03
25	0571015448	DRIVE AXLE		01
26	0571015450	CHAIN CAP		01
27	0503013061	50-1 CHAIN X 64 LINK + REDUCTION		01
28	0503013003	50-1 CHAIN X 79 LINK + REDUCTION + MENDING		01
29	0501053834	MALE QUICK COUPLER	7	02
30	0501081512	HOSE 1/2 X 800 TC-TC 90G		02
31	0501080246	TR-TM HOSE ASSY		02



HYDRAULIC DRIVE ASSY

0511056261

Item	Code	Description	See page	QT
32	0531011180	UPPER BODY CLIP		04
33	0503011102	BOLT 7/16 UNC X 1.1/4 C S G.5 ZN		04
34	0503010180	7/16" SPRING WASHER		04
35	0501060409	HOSE SOPPORT ASSY		01
36	0503010023	3/4" SPRING WASHER		01
37	0503010014	3/4" HEX NUT		01
38	0501069017	12Z GEAR		01
39	0581011125	LOCK WASHER		01
40	0521066606	OIL TUBE		02

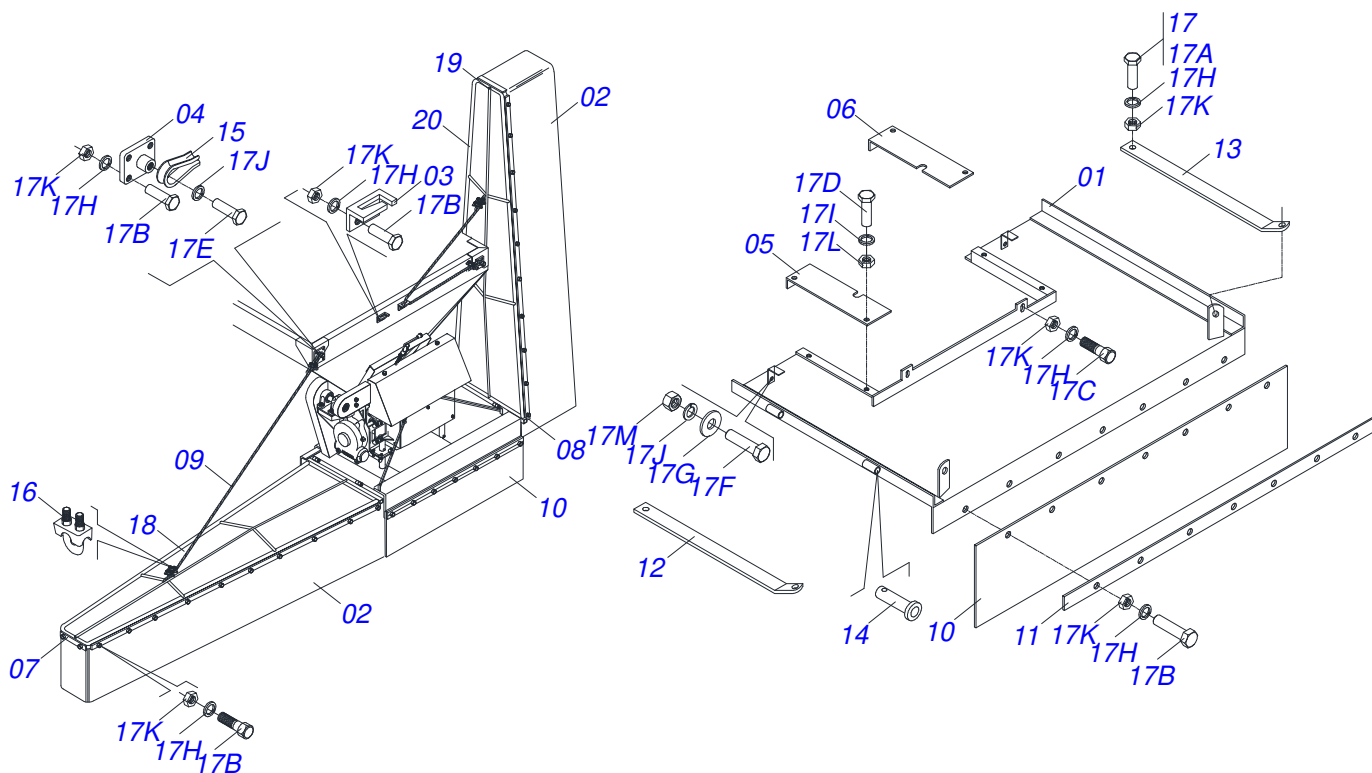

Item	Code	Description	See page	QT
01	0501067801	CENTRAL FRAME	01	01
02	0541010110	RUBBER BLANKET	02	02
03	0501066514	STELL GUIDE CABLO	02	02
04	0501066515	STELL SUPPORT CABLO	02	02
05	0511017104	RIGHT COVER SIDE	01	01
06	0511017105	LEFT COVER SIDE	01	01
07	0511013806	FIXER CANVAS RIBBON	02	02
08	0511013793	FIXER SUPPORT CANVAS	04	04
09	0511013817	STELL CABLE	02	02
10	0541010205	REAR PROTECTION	01	01
11	0511013804	REAR RIBBON FIXER BLANKET	01	01
12	0511017465	ATTACHMENT BAR	01	01
13	0511017466	ATTACHMENT BAR	01	01
14	0511013803	PIN	04	04
15	0503011202	BRACKET	04	04
16	0503010165	5/16" CABLO STEEL STAPLE	08	08
17	0501032349	PACKED PARTS	01	01
17A	0503010256	3/8" X 3/4" BOLT	04	04
17B	0503010237	3/8" X 1" BOLT	65	65
17C	0501010080	3/8" BOLT	02	02
17D	0503011102	BOLT 7/16 UNC X 1.1/4 C S G.5 ZN	04	04
17E	0503010834	1/2 X 1 BOLT	02	02
17F	0501010063	1/2" X 1-1/2" BOLT	02	02
17G	0511017302	FLAT WASHER 13,50 X 32,50 X 3,0 ZN	04	04
17H	0503010025	3/8 SPRING WASHER	71	71
17I	0503010180	7/16" SPRING WASHER	04	04
17J	0503010019	1/2" SPRING WASHER	04	04
17K	0503010026	3/8" NUT	71	71
17L	0503010244	7/16" NUT	04	04
17M	0503010060	1/2 UNC G.5 ZN HEX NUT	02	02
18	0501066442	RIGHT WING	01	01



DAMPER ASSY

0531052379

Item	Code	Description	See page	QT
19	0501066443	LEFT WING		01
20	0511013809	SUPPORT PROTECTION		02

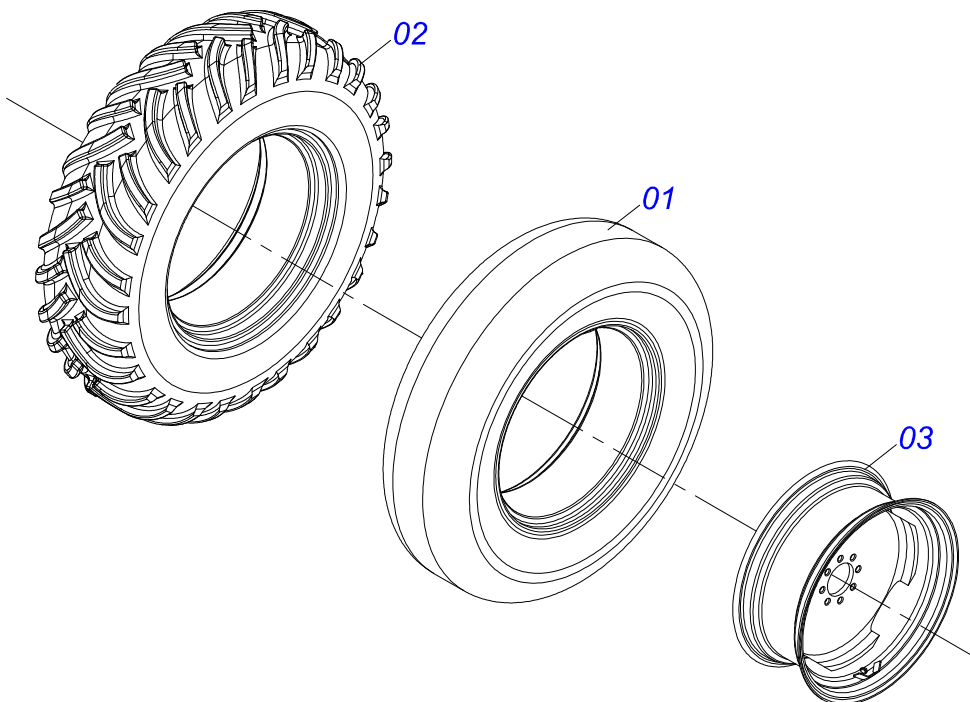

Item	Code	Description	See page	QT
01	0503013040	0.5" X 1" VALVE STEM		01
02	0503013039	0.5" X 1" -10 CANVAS TIRE		01
03	0511063924	DCCO 10500 WHEEL		01



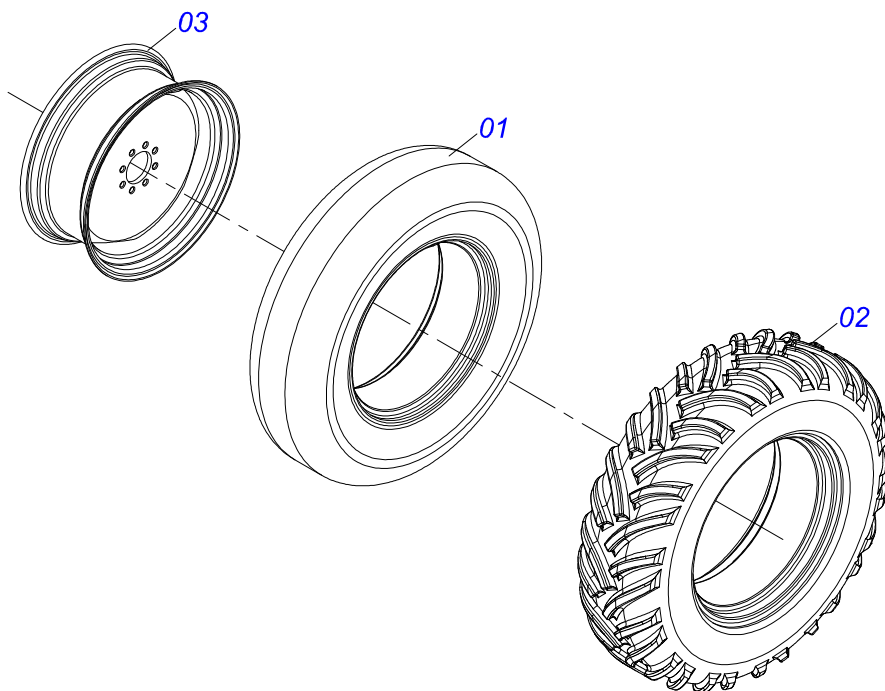

Item	Code	Description	See page	QT
01	0503013040	0.5" X 1" VALVE STEM		01
02	0503013039	0.5" X 1" -10 CANVAS TIRE		01
03	0511063924	DCCO 10500 WHEEL		01





**MARCHESAN**

**Technical Publications | Elaboration and Revision**

LORENA ROCHA ALVES

[www.marchesan.com.br](http://www.marchesan.com.br)

