

**CHASER BIN**

**DCA2 7500 MC WITH HYDRAULIC OPERATION  
DCA2 7500 MC COM ACIONAMENTO HIDRAULICO**

**Code:** 0501093165  
**Series:** S-0114  
**Revision:** 01  
**Revision Date:** FEBRUARY/2023

# PARTS CATALOGUE



**MARCHESAN**



# PRODUCTS

Code	Working Width	Description
0109090210		DCA2 7500 MC C/ABAFADOR/ACION HIDR S-0114
0109090344		DCA2 7500 MC C/ACION HIDR C/ ABAF S/PNEU S-0114
0109090170		DCA2 7500 MC C/ACIONAM HIDR S-0114

## ATTENTION: IMPORTANT

Marchesan S.A. reserves the right to improve and/or modify the technical features of its products, without obligation to do the same with those products already sold and without prior knowledge of the dealer or the customer. The photos are only illustrative.



**MARCHESAN**

# INDEX

0909096086	ASSY FRAME	.....	1
0521043447	ASSY FRAME WITH HYDRAULIC DRIVE	.....	2
0511054505	FRAME WITH BUCKET	.....	3
0511059305	REAR PROTECTION WITH MINOR PROTECTOR	.....	4
0501044308	AGRICULTURAL BEARING ASSY	.....	5
0501047985	REDUCER	.....	6
0501051774	38Z CROWN	.....	7
0501046802	BELT TENSIONER ASSY	.....	8
0501051782	RIGHT BEARING SUPPORT DISC	.....	9
0501051783	LEFT BEARING SUPPORT DISC	.....	10
0501048000	AGRICULTURAL BEARING	.....	11
0501051972	DISTRIBUTOR RIGHT DISC ASSY	.....	12
0501051973	DISTRIBUTOR LEFT DISC ASSY	.....	13
0511041213	AGRICULTURAL BEARING	.....	14
0531050244	PROTECTOR DISC	.....	15
0521057116	FULL HITCH	.....	16
0503062157	DRAWBAR JACK	.....	17
0521046046	FIXING STAND ASSY	.....	18
0501051142	CARRYING WHEEL HUB	.....	19
0501054846	SLUICE VALVE SUPPORT	.....	20
0511059094	SHAFT BEARING THREADED	.....	21
0501054847	SLUICE VALVE COVER ASSY	.....	22
0521057956	HYDRAULIC DRIVE ASSY	.....	23
0511053588	MOTOR HYDRAULIC OMP 80 WITH NIPPLE 7/8 NIPPE 7/8	.....	24
0511054496	TENSIONER SMALEER ASSY	.....	25
0511054497	TENSIONER LARGER ASSY	.....	26
0521057951	SUPPORT SIMPLE HYDRAULIC DRIVE	.....	27
0521057953	BLOCK HYDAC	.....	28
0521057952	FILTER PRES PARKER HDA FP20 10FV 06B LV6	.....	29
0521057599	FILTER PRESS PARKER HDA FP20 10FV 06B LV6 WITH NIPPLE	.....	30
0521057978	SIMPLE HYDRAULIC ACTUATION HOSE SET	.....	31
0501053834	MALE QUICK COUPLER	.....	32
0521058094	SUPPORT HOSE	.....	33
0531050245	ASSY MANUAL DOOR	.....	34
0521046544	ASSY FRAME WITH HYDRAULIC DRIVE	.....	35
0511054498	HYDRAULIC CONTROL KIT	.....	36
0531051665	DAMPER	.....	37
0503060181	WHEEL AND TIRE	.....	38

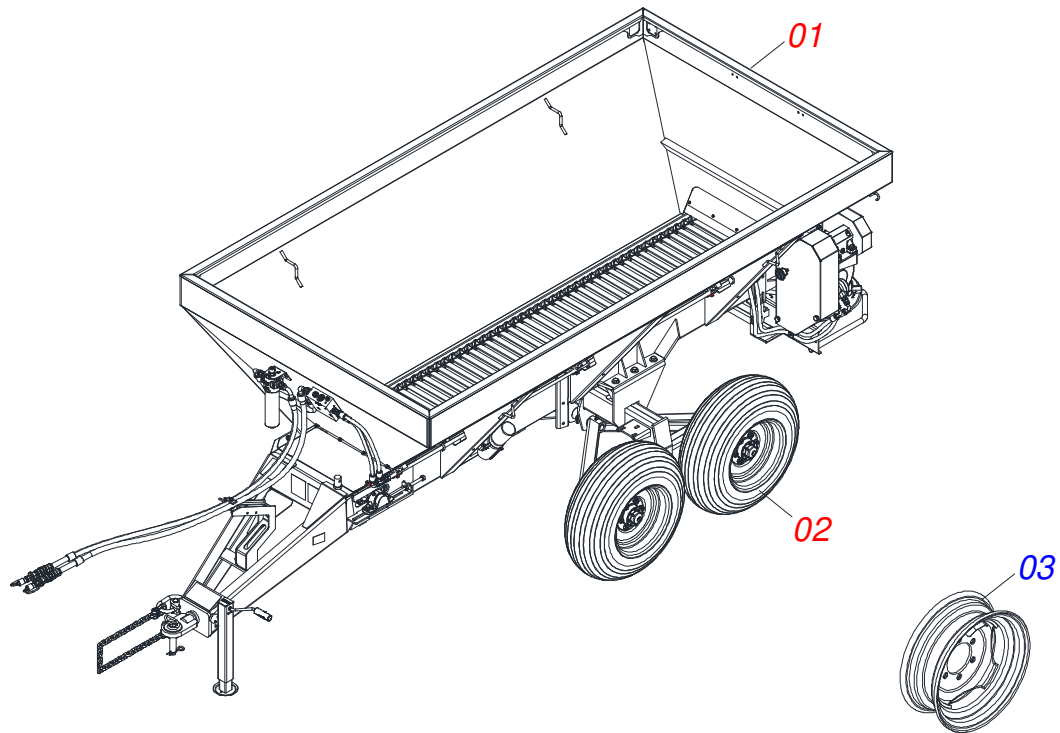

Item	Code	Description	See page	QT
01	0521043447	ASSY FRAME WITH HYDRAULIC DRIVE	2	01
01.	0521046544	ASSY FRAME WITH HYDRAULIC DRIVE	35	01
02	0503060181	WHEEL AND TIRE	38	04
03	0503011468	WEEL		04

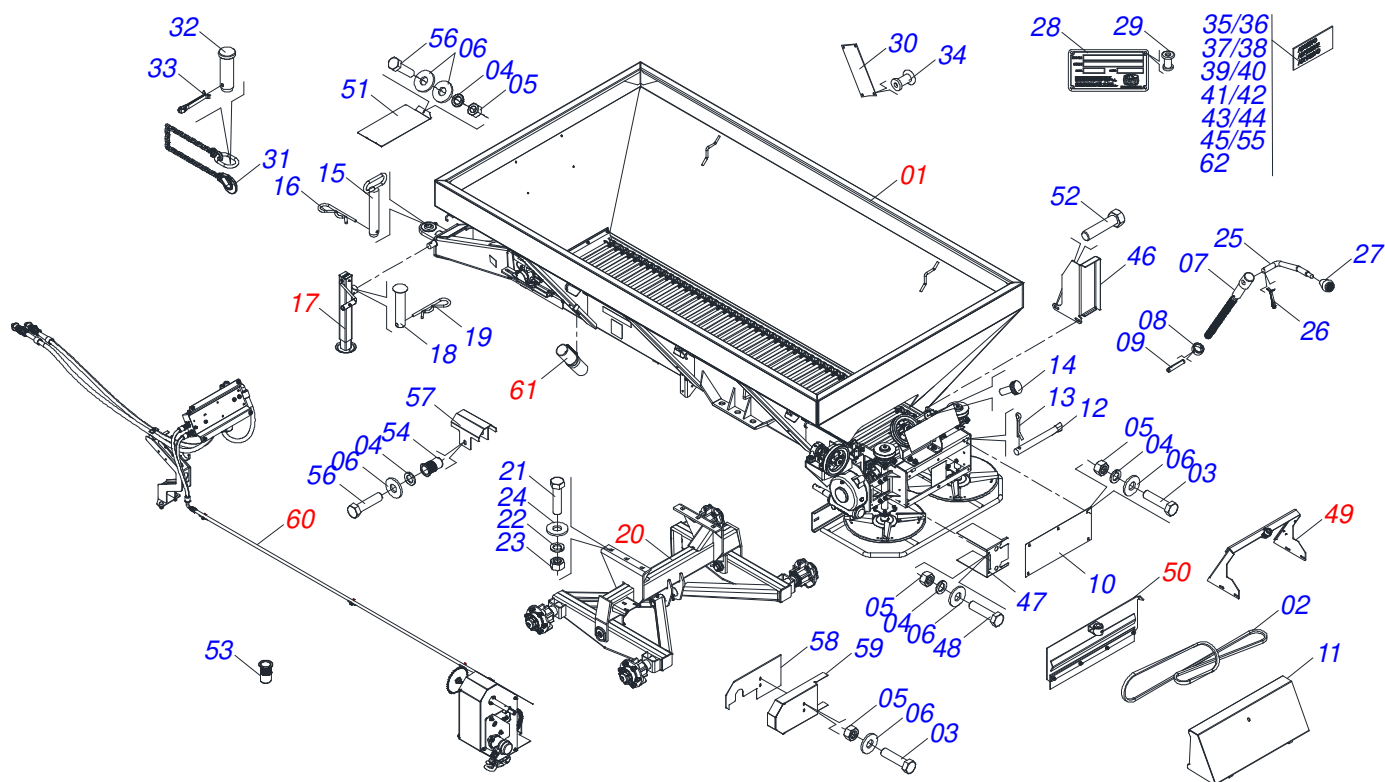

Item	Code	Description	See page	QT
01	0511054505	FRAME WITH BUCKET	3	01
02	0503019347	BELT		01
03	0503010237	3/8" X 1" BOLT		11
04	0503010025	3/8 SPRING WASHER		19
05	0503010026	3/8" NUT		11
06	0501010984	10,50 X 27 X 3,00 FLAT WASHER		22
07	0561014861	REGULATOR		01
08	0511013015	SLEEVE		01
09	0503010561	SPRING PIN		01
10	0501019460	REAR PROTECTION		01
11	0501069840	REAR COVER PROTECTION		01
12	0501017574	0.3" X 2.7" AXLE		02
13	0503010140	1/8" X 3/4" SPLIT PIN		02
14	0503010386	CABLE		01
15	0501069080	COUPLING SHAFT		01
16	0503031035	HITCH PIN CLIP		01
17	0503062157	DRAWBAR JACK	17	01
18	0521010549	COUPLING SHAFT		01
19	0503030168	HITCH PIN CLIP		01
20	0521046046	FIXING STAND ASSY	18	01
21	0503010899	5/8 UNC X 2.1/4 BOLT		06
22	0503010027	5/8 SPRING WASHER		06
23	0503010013	5/8" UNC G.5 ZN HEX NUT		06
24	0501012140	FLAT WASHER 16,50 X 40 X 4,00 ZN		12
25	0521011107	CRANK BODY		01
26	0503010257	1/8" X 1" SPLIT PIN		01
27	0503030878	LEVER CRANK		01
28	0503034003	61 X 118 SERIAL NUMBER TAG		01
29	0503010001	RIVET 3,2 X 5,5		04
30	0503030751	REGULATOR PLATE		01



**DCA2 7500 MC WITH HYDRAULIC OPERATION**  
**ASSY FRAME WITH HYDRAULIC DRIVE**

Item	Code	Description	See page	QT
31	0503013150	1300 X 3/8" CHAIN		01
32	0581011220	COUPLING SHAFT		01
33	0503010131	3/16" X 1.1/2" SPLIT PIN		01
34	0503012209	RIVET POP		04
35	0503031859	ADHESIVE LABEL DANGER		01
36	0503031809	ADHESIVE LABEL		01
37	0503031428	READ MANUAL DECAL		01
38	0503031827	LUBRICATE AND RETIGHTEN DAILY DECAL		01
39	0503031818	ADHESIVE LABEL		01
40	0503031087	AUTO CONTROL APPROVED DECAL		01
41	0503032425	ADHESIVE LABEL ATTENTION		01
42	0503032949	ATTENTION 3 LANGUAGES DECAL		01
43	0503031427	ADHESIVE LABEL		01
44	0503034640	ADHESIVE LABEL		02
45	0503034641	ADHESIVE LABEL		02
46	0581017492	SIDE PROTECTION BELT		01
47	0581017497	COUPLING PROTECTION		01
48	0503010256	3/8" X 3/4" BOLT		02
49	0501054846	SLUICE VALVE SUPPORT	20	01
50	0501054847	SLUICE VALVE COVER ASSY	22	01
51	0581017493	FRONT PROTECTION		01
52	0503010849	3/8" X 1-1/2" BOLT		04
53	0503019413	THREAD SCREW INTERNAL		04
54	0503019416	RIVET SCREW THREAD INTERNAL		02
55	0503035157	ADHESIVE LABEL DISTRIBUTOR LIMESTONE		01
56	0501010942	3/8" X 1-1/4" BOLT		02
57	0591016133	COVER PROTECTION AXLE		01
58	0591016135	REAR COVER PROTECTION COVER		01
59	0591016134	PROTECTION COVER		01
60	0521057956	HYDRAULIC DRIVE ASSY	23	01
61	0531050245	ASSY MANUAL DOOR	34	01
62	0503036144	MAXIMUM SPEED ADHESIVE LABEL		01

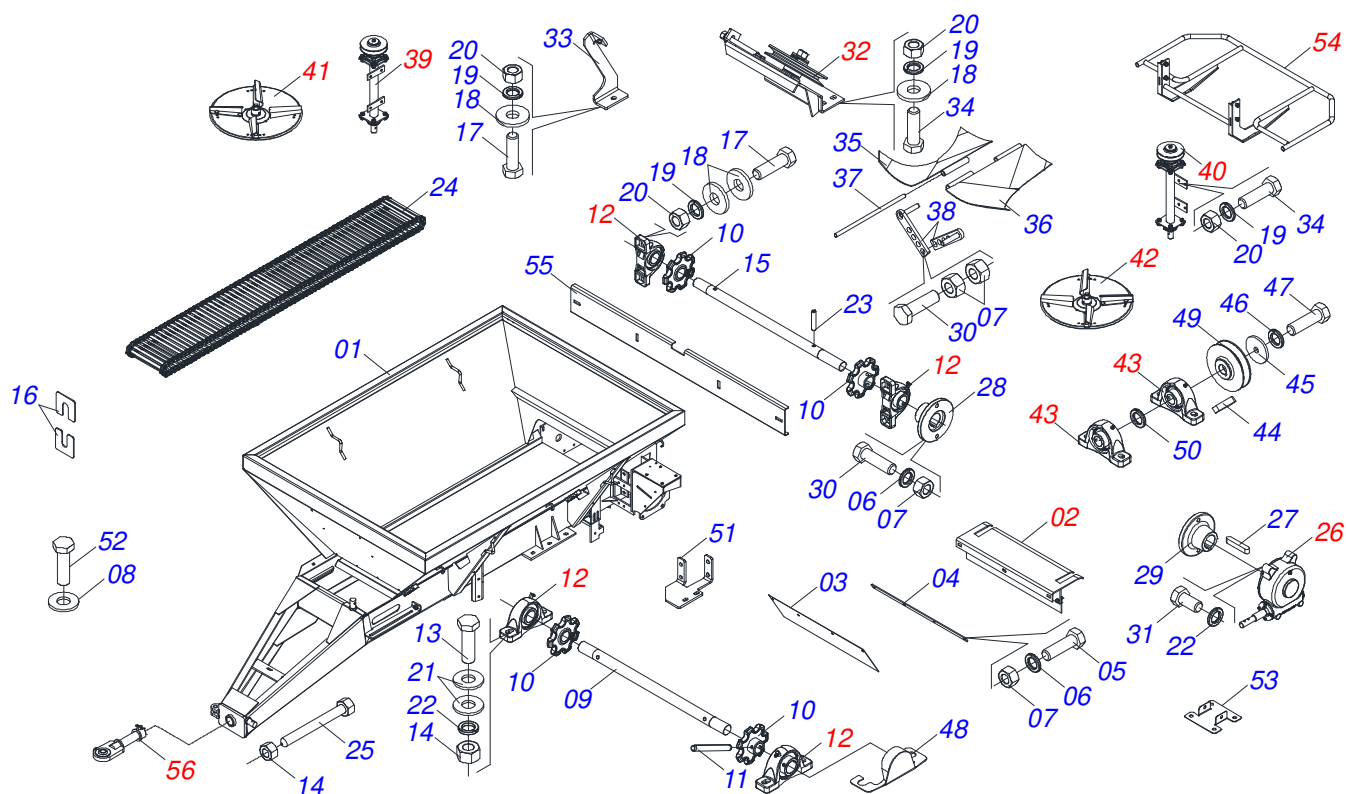

Item	Code	Description	See page	QT
01	0501069575	DCA2 7500 MC S-0598 BUCKET		01
02	0511059305	REAR PROTECTION WITH MINOR PROTECTOR	4	01
03	0511011866	PROTECTION LARGER		01
04	0511016575	RUBBER COVER FIXER		01
05	0503010237	3/8" X 1" BOLT		07
06	0503011443	SPRING WASHER 3/8"		11
07	0503010026	3/8" NUT		13
08	0501010984	10,50 X 27 X 3,00 FLAT WASHER		05
09	0511016482	DRIVEN AXLE		01
10	0502040728	7Z GEAR		04
11	0503010361	SPRING PIN		06
12	0501044308	AGRICULTURAL BEARING ASSY	5	04
13	0503010233	5/8" X 2-1/2" BOLT		04
14	0503010013	5/8" UNC G.5 ZN HEX NUT		06
15	0511016481	MOTOR SHAFT		01
16	0501010794	HIDR CHOCK REGULATOR		04
17	0503010740	BOLT 1/2 UNC X 2 CS G.5 ZN		08
18	0511017302	FLAT WASHER 13,50 X 32,50 X 3,0 ZN		17
19	0503011440	SPRING WASHER		21
20	0503010060	1/2 UNC G.5 ZN HEX NUT		21
21	0501012140	FLAT WASHER 16,50 X 40 X 4,00 ZN		08
22	0503011445	SPRING WASHER		08
23	0503010756	0.2" X 2.4" SPRING PIN		04
24	0501067378	DRIVE THE FERTILIZER TRANSPORT		01
25	0501067853	ROD STABILIZER		02
26	0501047985	REDUCER	6	01
27	0501010540	KEYWAY SQUARE		02
28	0511016540	MAT COUPLING FLANGE		01
29	0511016541	REDUCTION COUPLING FLANGE		01
30	0503010849	3/8" X 1-1/2" BOLT		03



**DCA2 7500 MC WITH HYDRAULIC OPERATION**  
**FRAME WITH BUCKET**

Item	Code	Description	See page	QT
31	0503011167	M16 X 2 X 30 BOLT		04
32	0501046802	BELT TENSIONER ASSY	8	01
33	0511060909	PROTECTION REAR SUPPORT FIXER		01
34	0503010920	1/2 UNC X 1.1/2 C S G.5 ZN BOLT		13
35	0501067203	RIGHT FLOW DIVIDING		01
36	0501067361	LEFT FLOW DIVIDING		01
37	0511016530	TENSIONER OPEN		01
38	0501067368	DIVISOR REGULATOR OPEN		02
39	0501051782	RIGHT BEARING SUPPORT DISC	9	01
40	0501051783	LEFT BEARING SUPPORT DISC	10	01
41	0501051972	DISTRIBUTOR RIGHT DISC ASSY	12	01
42	0501051973	DISTRIBUTOR LEFT DISC ASSY	13	01
43	0511041213	AGRICULTURAL BEARING	14	02
44	0501010536	KEYWAY SQUARE		01
45	0511014052	FLAT WASHER		01
46	0503011446	SPRING WASHER		01
47	0503010355	7/16" X 1" BOLT		01
48	0521068822	BEARING PROTECTION		03
49	0502012936	1 C X 219 X 30 PULLEY		01
50	0511016579	WASHER		01
51	0591016143	FIXER SUPPORT BELT PROTECTION		01
52	0503010751	C3/8" X 1.1/4" HEX BOLT G.5		02
53	0591016132	FIXER BODY PROTECTION COVER		01
54	0531050244	PROTECTOR DISC	15	01
55	0531061809	FENDER CLAMP		01
56	0521057116	FULL HITCH	16	01



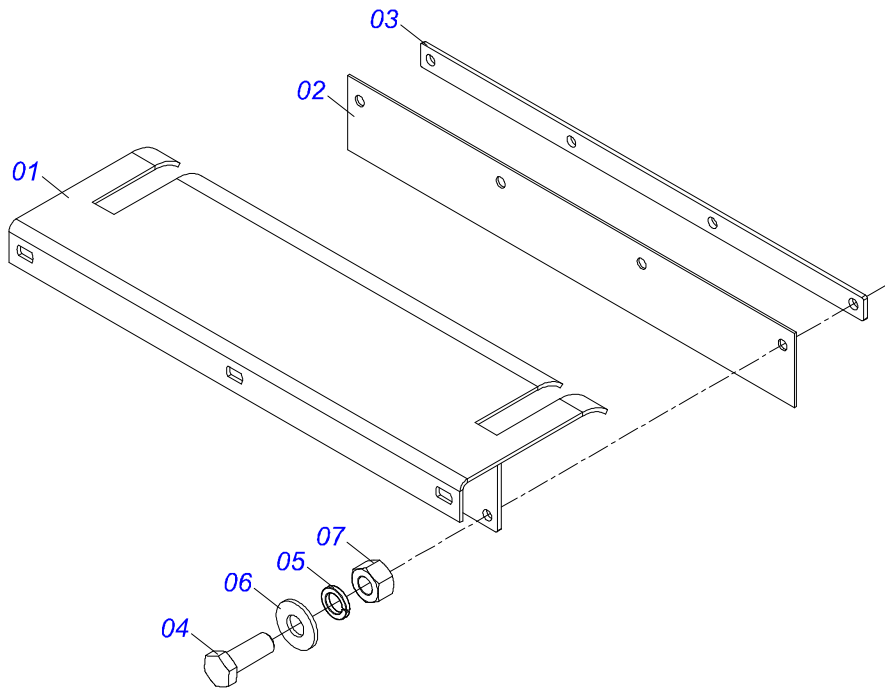

Item	Code	Description	See page	QT
01	0501067379	MAT REAR PROTECTION		01
02	0511014562	PROTECTION SMALLER		01
03	0511016575	RUBBER COVER FIXER		01
04	0503010237	3/8" X 1" BOLT		04
05	0503011443	SPRING WASHER 3/8"		04
06	0501010984	10,50 X 27 X 3,00 FLAT WASHER		04
07	0503010026	3/8" NUT		04

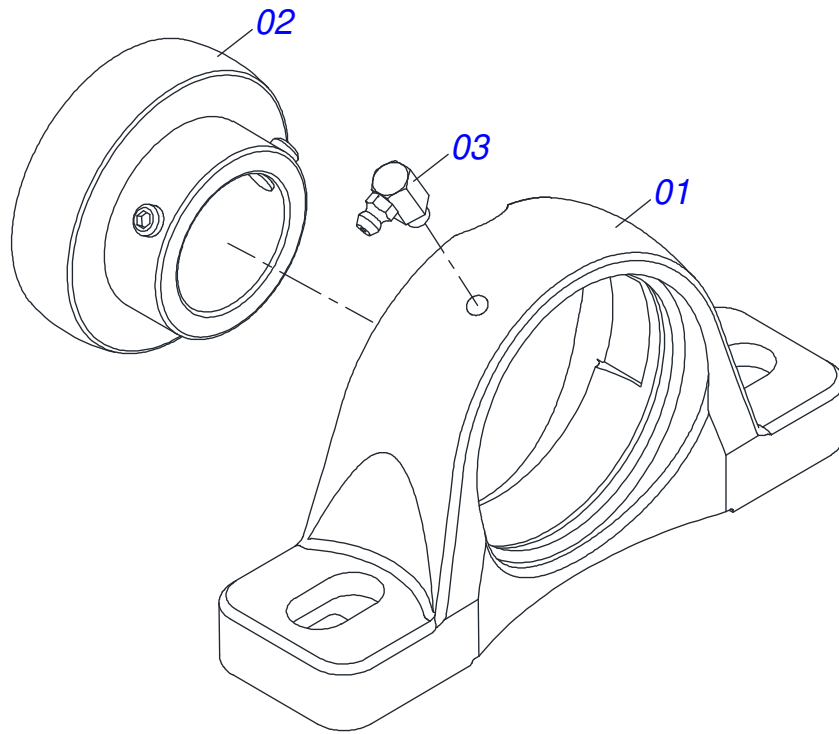

Item	Code	Description	See page	QT
01	0502011050	AGRICULTURAL HOUSING BEARING		01
02	0503011163	1108/UCR BEARING ASSY		01
03	0503010004	1890 GREASE FITTING		01

REDUCER

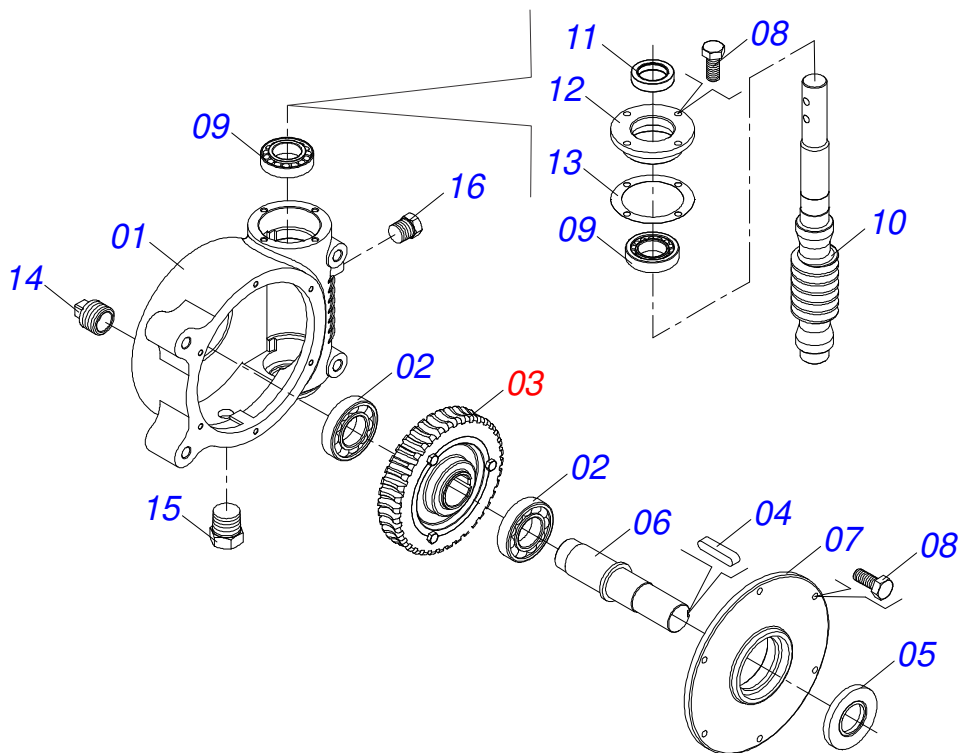

Item	Code	Description	See page	QT
01	0502011456	REDUCTION BOX		01
02	0503011095	6208 BALL BEARING		02
03	0501051774	38Z CROWN	7	01
04	0503011304	1/2" X 2.4" KEYWAY SQUARE		01
05	0503010818	02675-BRG SEAL		01
06	0521010996	AXLE		01
07	0502020556	LARGER COVER		01
08	0503010240	BOLT		10
09	0503010016	BEARING LM		02
10	0521010997	SCREW THEAD		01
11	0503011171	00912-BRG SEAL		01
12	0502011457	SMALLER COVER		01
13	0503030981	102 X 75,5 X 0,10 JOINT		01
14	0521011023	PLUG		01
15	0513010009	LEVEL DISPLAY		01
16	0503010856	OIL PLUG R 3/8 BSPT		01

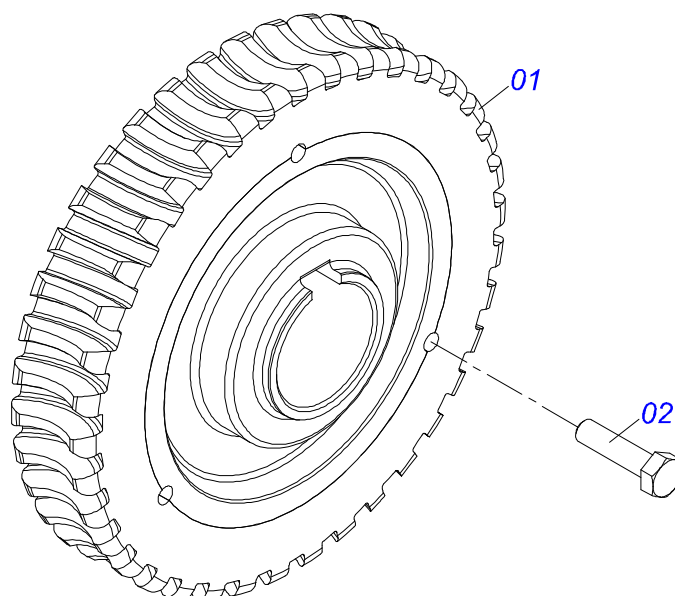

Item	Code	Description	See page	QT
01	0501110280	38Z CONICAL		01
02	0503010365	BOLT 5/16 UNC X 1.1/4 C S G.5 ZN		03

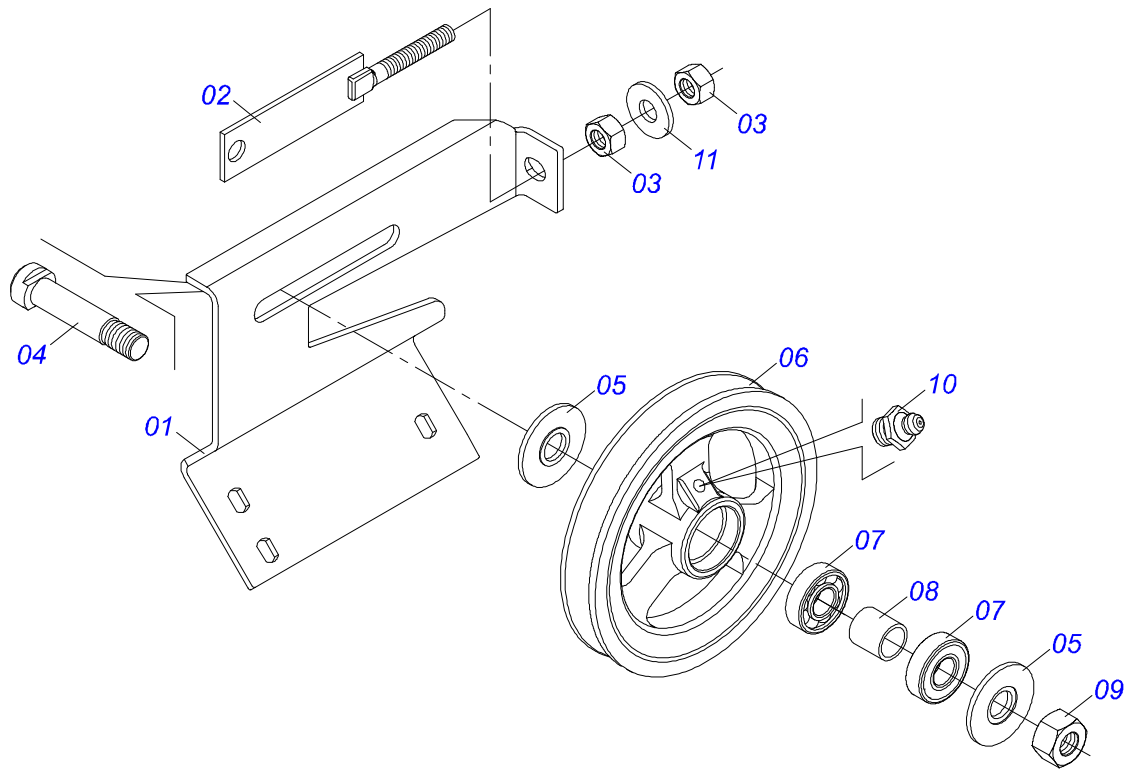

Item	Code	Description	See page	QT
01	0501066100	SUPPORT		01
02	0501065968	1C X 8.3 PULLEY TENSIONER		01
03	0503010013	5/8" UNC G.5 ZN HEX NUT		02
04	0511012362	TIGHTENER AXLE PULLEY		01
05	0501019288	WASHER SPACER		02
06	0502011366	REEL 1C 8.3" X 1.6" PULLEY		01
07	0503010690	6204 BALL BEARING		02
08	0521010497	0.8" X 1.1" X 1.1" SPACER		01
09	0503010014	3/4" ZN G.5 (HEAVY) UNC HEX NUT		01
10	0503010002	1800 GREASE FITTING		01
11	0501012140	FLAT WASHER 16,50 X 40 X 4,00 ZN		01

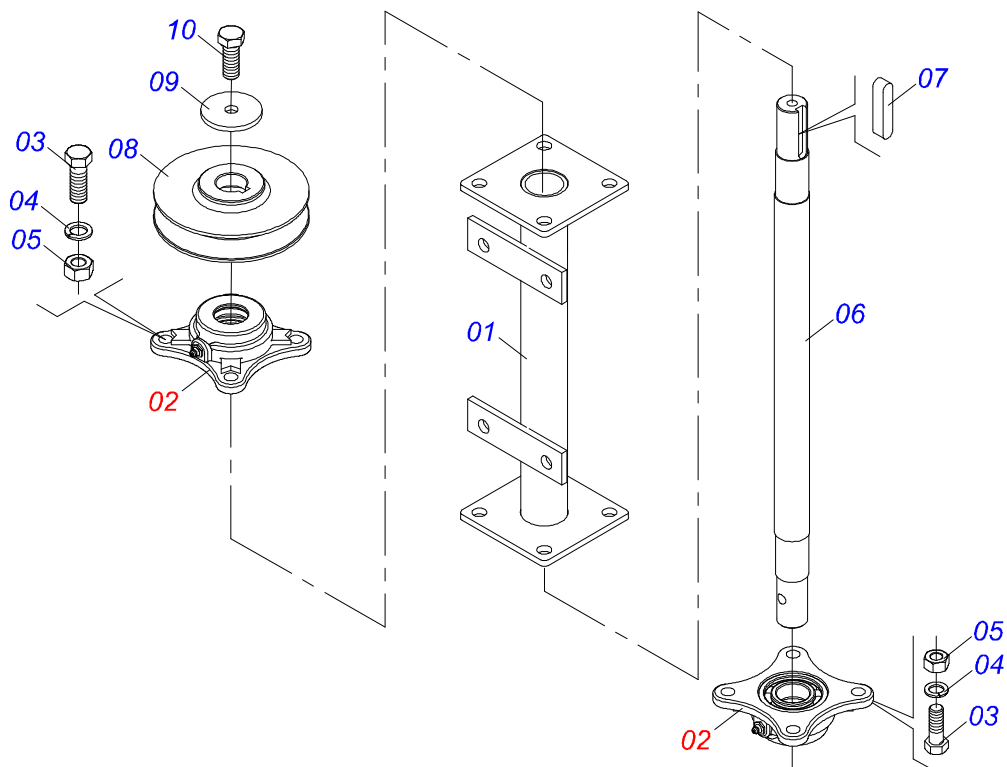

Item	Code	Description	See page	QT
01	0501067387	DISTRIBUTOR RIGHT SUPPORT DISC		01
02	0501048000	AGRICULTURAL BEARING	11	02
03	0503011102	BOLT 7/16 UNC X 1.1/4 C S G.5 ZN		08
04	0503011446	SPRING WASHER		08
05	0503010244	7/16" NUT		08
06	0511016489	DISTRIBUTOR AXLE CONDUCTOR DISC		01
07	0501010536	KEYWAY SQUARE		01
08	0502011361	REEL 1C 5.5" X 1.1" PULLEY		01
09	0511014052	FLAT WASHER		01
10	0503010355	7/16" X 1" BOLT		01

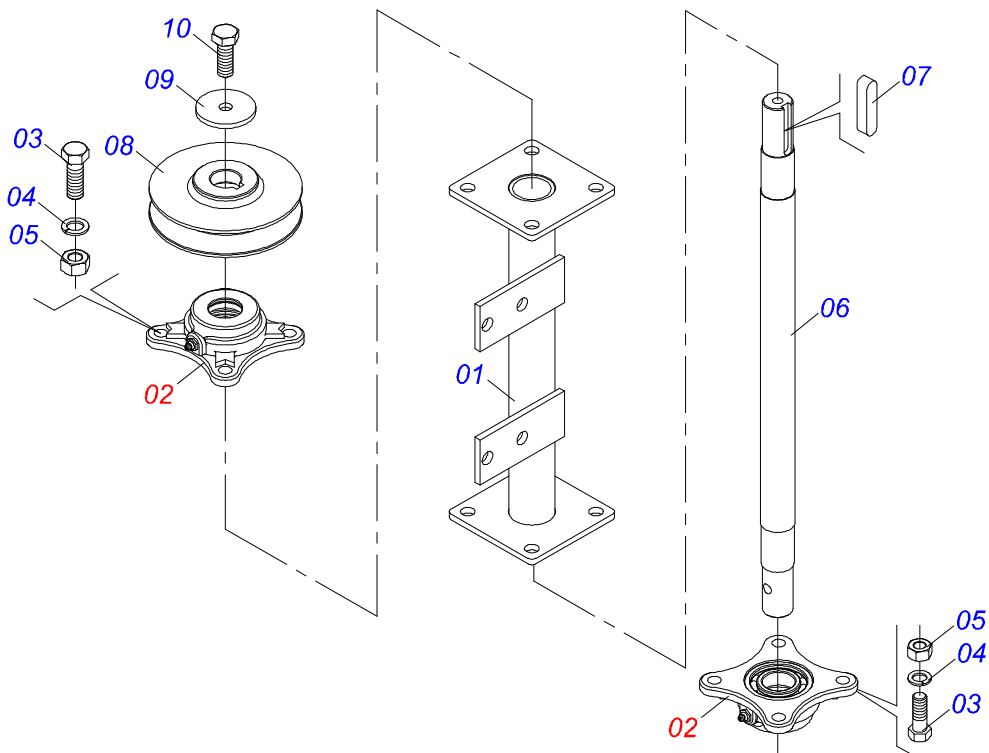

Item	Code	Description	See page	QT
01	0501067388	DISTRIBUTOR LEFT SUPPORT DISC		01
02	0501048000	AGRICULTURAL BEARING	11	02
03	0503011102	BOLT 7/16 UNC X 1.1/4 C S G.5 ZN		08
04	0503011446	SPRING WASHER		08
05	0503010244	7/16" NUT		08
06	0511016489	DISTRIBUTOR AXLE CONDUCTOR DISC		01
07	0501010536	KEYWAY SQUARE		01
08	0502011361	REEL 1C 5.5" X 1.1" PULLEY		01
09	0511014052	FLAT WASHER		01
10	0503010355	7/16" X 1" BOLT		01

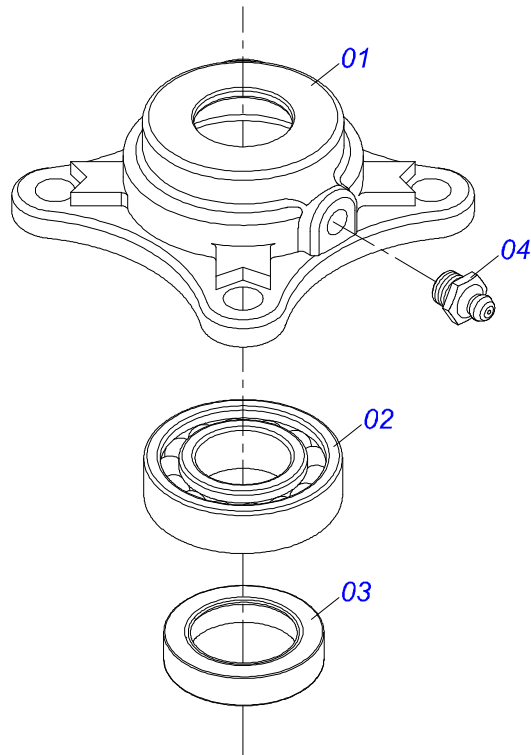

Item	Code	Description	See page	QT
01	0502011442	AGRICULTURAL HOUSING BEARING		01
02	0503010276	6206 BALL BEARING		01
03	0503011865	SEAL		01
04	0503010002	1800 GREASE FITTING		01



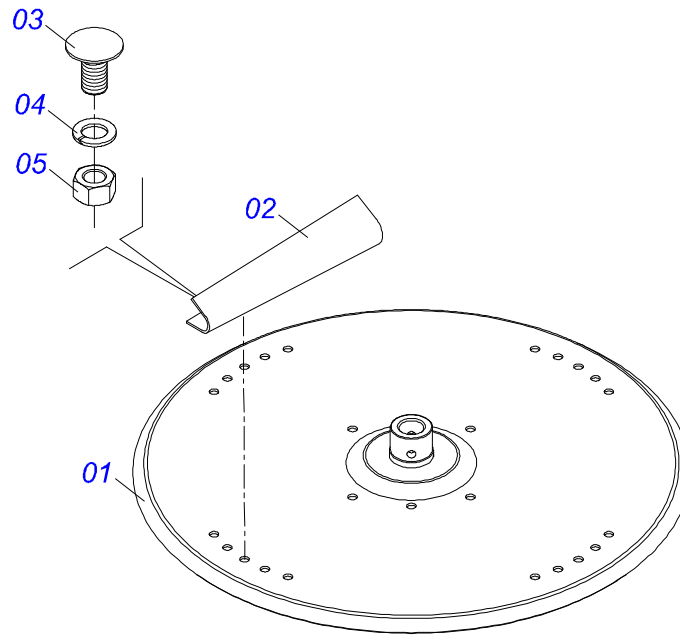

Item	Code	Description	See page	QT
01	0501069605	DISTRIBUTOR DISC		01
02	0521018638	LH FLIP		04
03	0503013029	3/8" X 3/4" BOLT		08
04	0503011443	SPRING WASHER 3/8"		08
05	0503010026	3/8" NUT		08

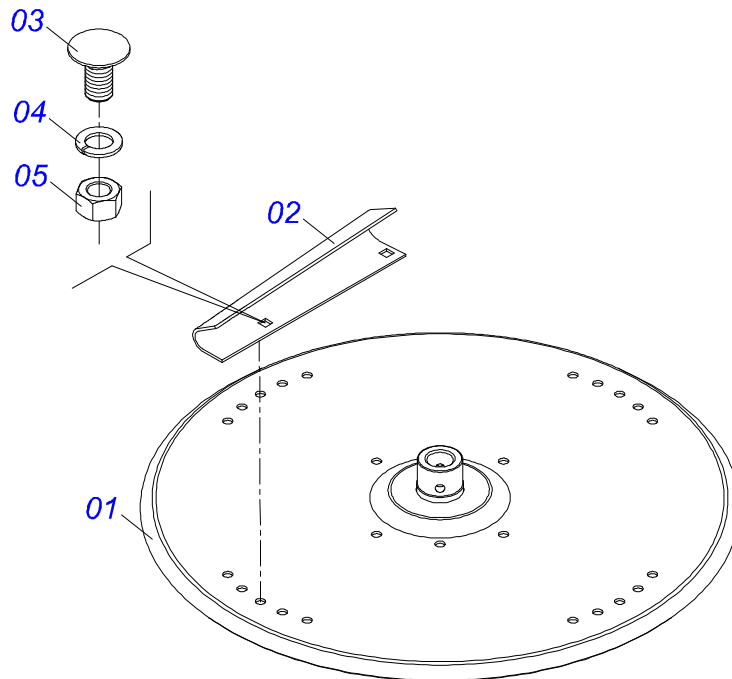

Item	Code	Description	See page	QT
01	0501069605	DISTRIBUTOR DISC		01
02	0521018637	LEFT FLIP		04
03	0503013029	3/8" X 3/4" BOLT		08
04	0503011443	SPRING WASHER 3/8"		08
05	0503010026	3/8" NUT		08

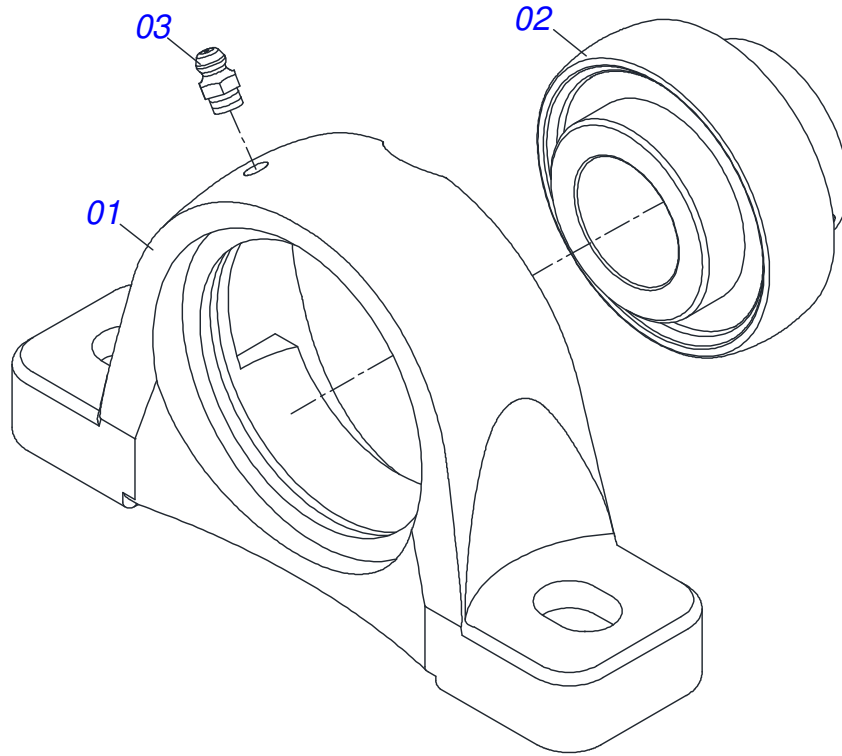

Item	Code	Description	See page	QT
01	0502011954	AGRICULTURAL HOUSING BEARING		01
02	0503011884	BALL BEARING		01
03	0503010691	1/4" GREASE FITTING		01

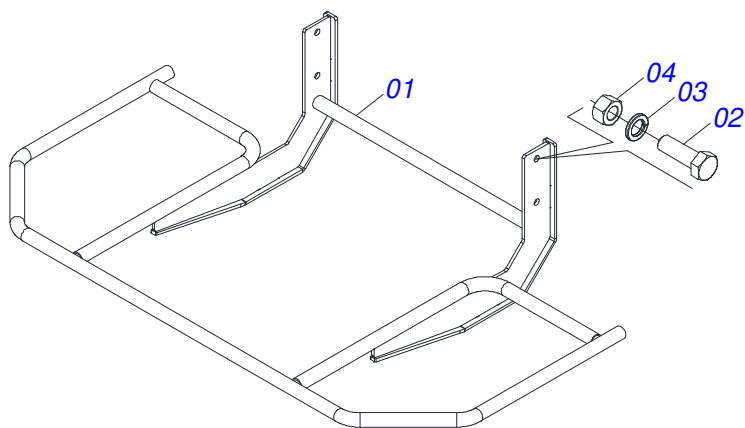

Item	Code	Description	See page	QT
01	0531061810	DISC PROTECTION		01
02	0503010920	1/2 UNC X 1.1/2 C S G.5 ZN BOLT		04
03	0503011440	SPRING WASHER		04
04	0503010060	1/2 UNC G.5 ZN HEX NUT		04

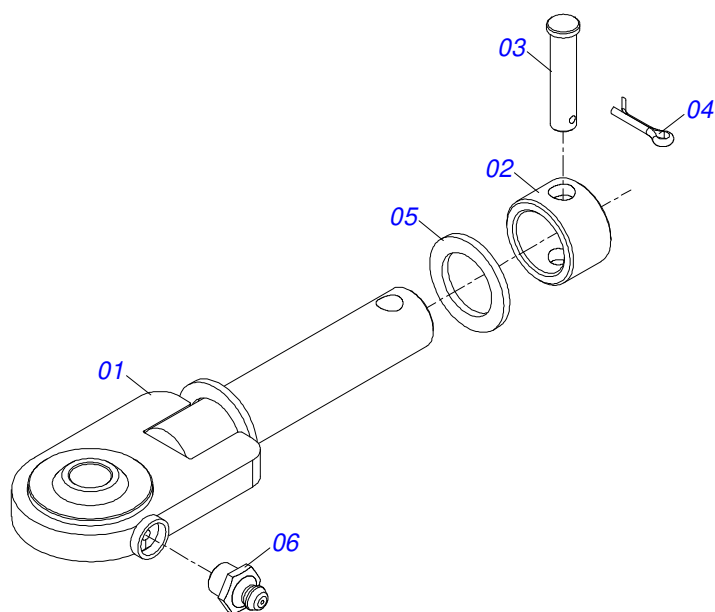

Item	Code	Description	See page	QT
01	0521068793	TRACTOR TRACTOR		01
02	0521010681	BUSHING COUPLING BODY		01
03	0521010639	COUPLING SHAFT		01
04	0503010571	1/4" X 1.1/2" SPLIT PIN		01
05	0501015875	FLAT WASHER		01
06	0503010002	1800 GREASE FITTING		01

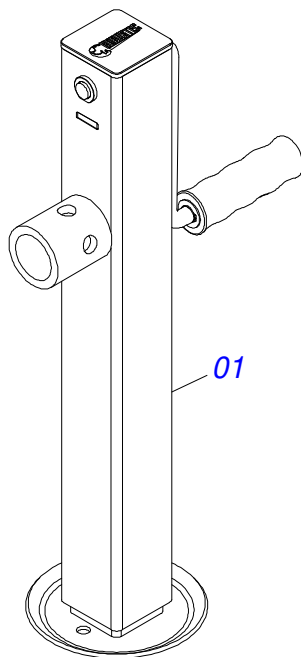

Item	Code	Description	See page	QT
01	0503062157	DRAWBAR JACK	17	01

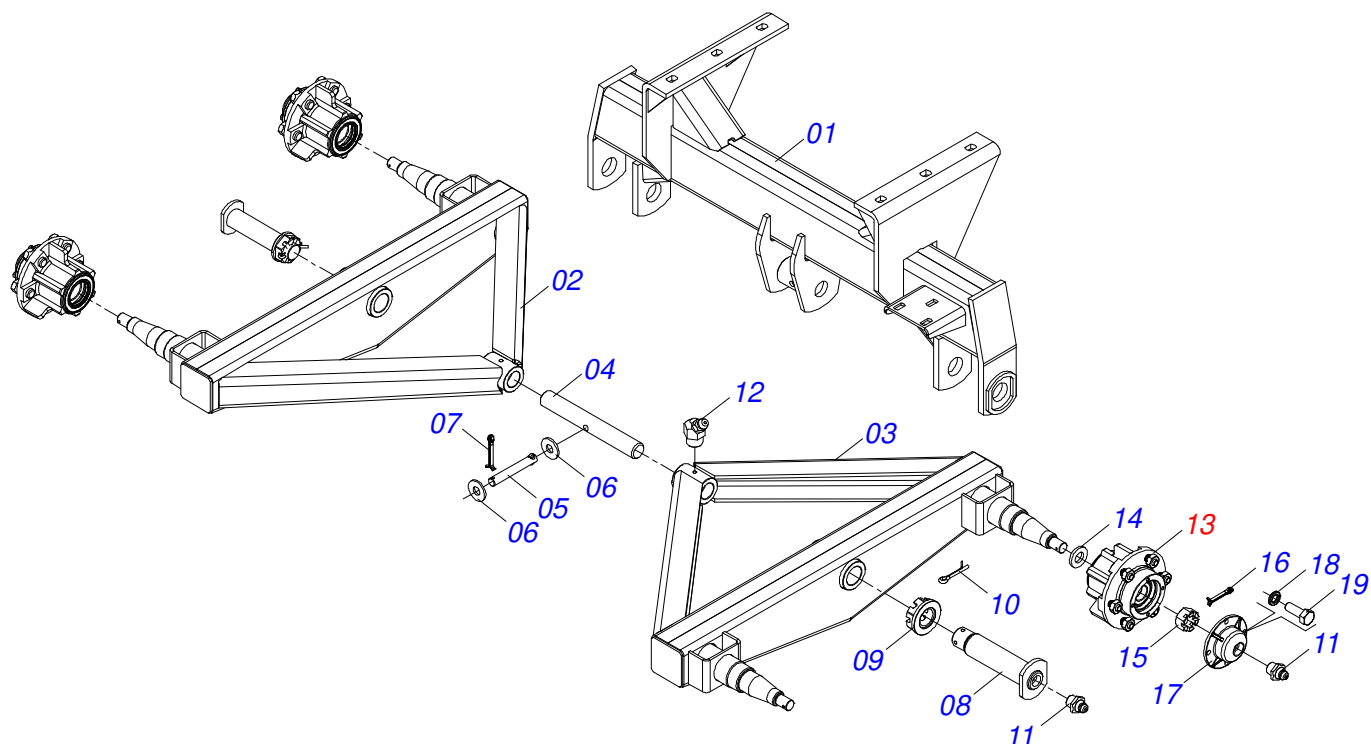

Item	Code	Description	See page	QT
01	0521063773	BALANCING FIXATION SUPPORT		01
02	0501069577	RIGHT ROCKER ARM		01
03	0501069578	LEFT BELL CRANCK		01
04	0521012427	1.5" X 11.4" COUPLING SHAFT		01
05	0521010553	0.5" X 3" COUPLING SHAFT		01
06	0511017302	FLAT WASHER 13,50 X 32,50 X 3,0 ZN		02
07	0503010577	3/16" X 1.1/4" SPLIT PIN		01
08	0521012431	1-1/2" 7.6 PIVOT SHAFT		02
09	0501011301	1.1/2" UNC 6FPP 2.5/16" NUT		02
10	0503010010	SPLIT PIN 1/4" X 2.1/2"		02
11	0503010002	1800 GREASE FITTING		06
12	0503010003	1845 GREASE FITTING		02
13	0501051142	CARRYING WHEEL HUB	19	04
14	0501016545	FLAT WASHER		04
15	0503030009	1" CASTLE NUT		04
16	0503010131	3/16" X 1.1/2" SPLIT PIN		04
17	0502020591	PROTECCION COVER		04
18	0503011444	SPRING WASHER 5/16"		16
19	0503010358	5/16" X 5/8" BOLT		16

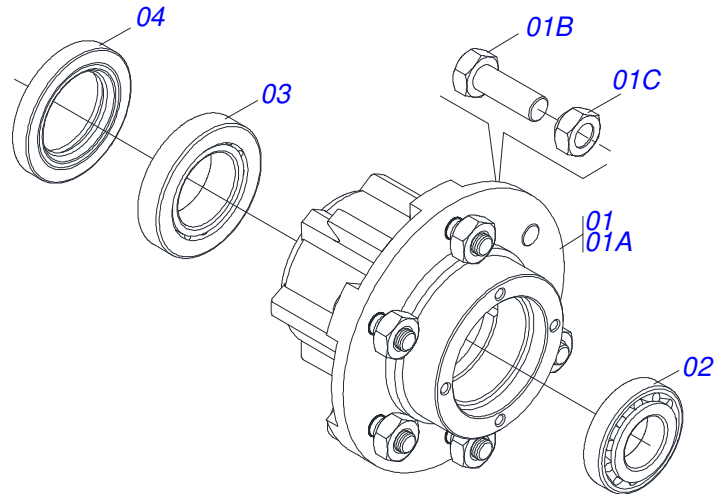

Item	Code	Description	See page	QT
01	0501110728	WHEEL HUB		01
01A	0502011121	CARRYING WHEEL HUB		01
01B	0501010127	9/16" X 1-7/8" LUG BOLT		06
01C	0503010035	9/16" CONIC NUT		06
02	0503010037	30207 ROLLER BEARING		01
03	0503010006	32210 ROLLER BEARING		01
04	0503012928	SEAL		01



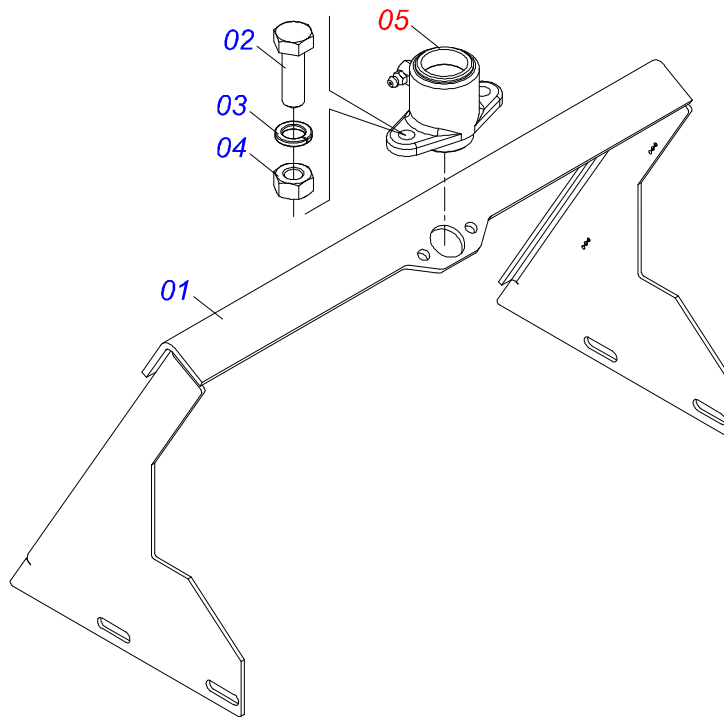

Item	Code	Description	See page	QT
01	0501069841	SLUICE VALVE SUPPORT		01
02	0503010371	5/16" X 1" BOLT		02
03	0503011444	SPRING WASHER 5/16"		02
04	0503010337	NUT 5/16 UNC G.5 ZN		02
05	0511059094	SHAFT BEARING THREADED	21	01

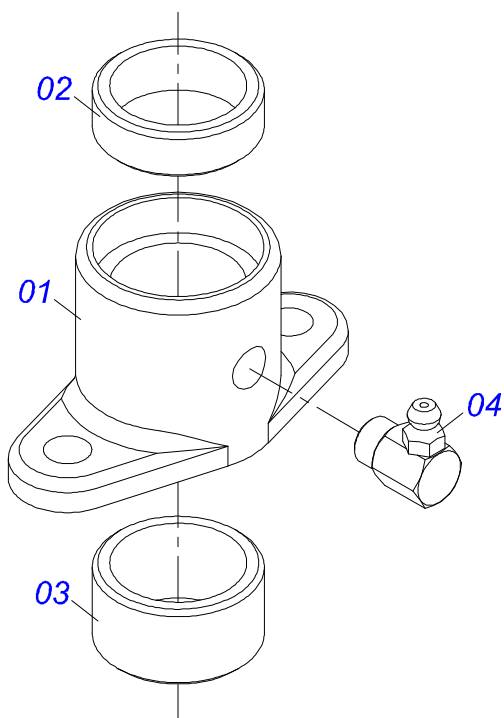

Item	Code	Description	See page	QT
01	0502010581	ROD BEARING		01
02	0521010458	SLEEVE		01
03	0521010457	SLEEVE		01
04	0503010004	1890 GREASE FITTING		01

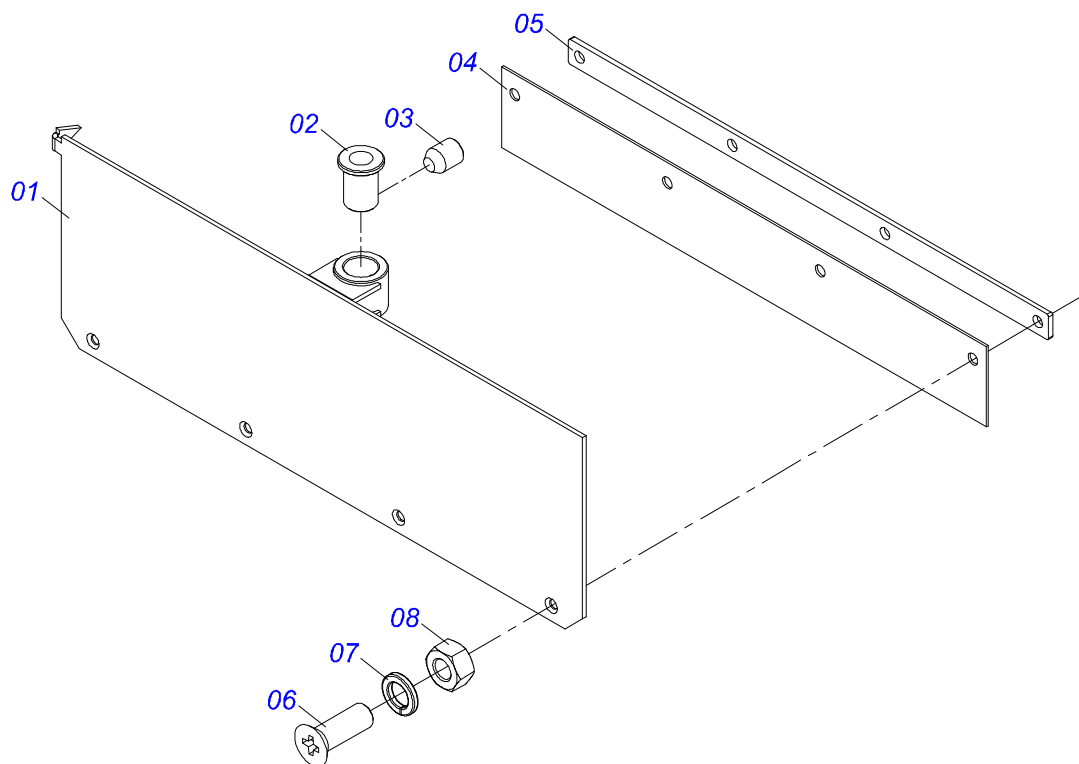

Item	Code	Description	See page	QT
01	0501069181	SLUICE VALVE COVER		01
02	0501019831	ADJUSTING NUT		01
03	0503011148	3/8" X 1/2" BOLT		01
04	0511014562	PROTECTION SMALLER		01
05	0511016575	RUBBER COVER FIXER		01
06	0503010546	5/16" X 7/8" BOLT		04
07	0503011444	SPRING WASHER 5/16"		04
08	0503010337	NUT 5/16 UNC G.5 ZN		04

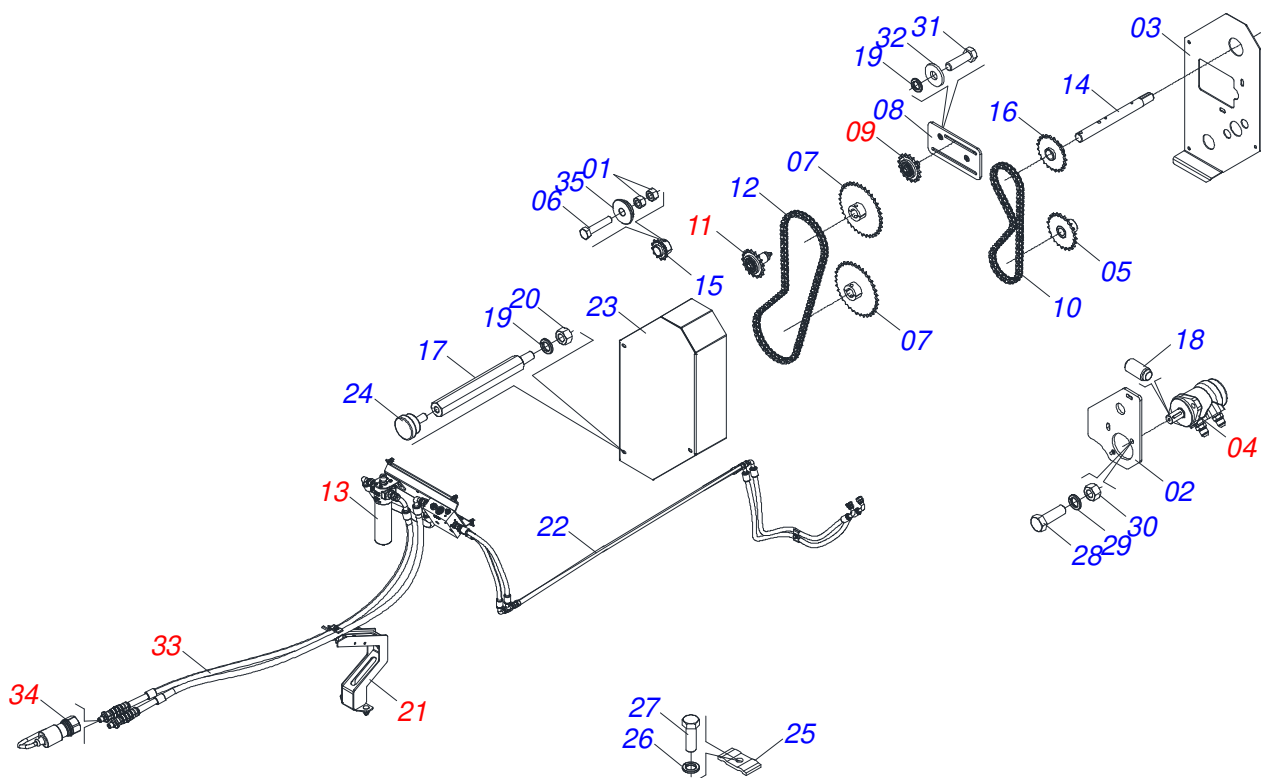

Item	Code	Description	See page	QT
01	0503010026	3/8" NUT		08
02	0571015182	HIDRAULIC MOTOR SUPPORT		01
03	0571015447	PROTETION REAR		01
04	0511053588	MOTOR HYDRAULIC OMP 80 WITH NIPPLE 7/8 24 NIPPE 7/8		01
05	0521064566	GEAR HIDRAULIC MOTOR		01
06	0503011141	3/8" X 2-3/4" BOLT		04
07	0501069020	35Z GEAR		02
08	0521064691	SUPPORT TENSIONER		01
09	0511054496	TENSIONER SMALEER ASSY	25	01
10	0503013061	50-1 CHAIN X 64 LINK + REDUCTION		01
11	0511054497	TENSIONER LARGER ASSY	26	01
12	0503013003	50-1 CHAIN X 79 LINK + REDUCTION + MENDING		01
13	0521057951	SUPPORT SIMPLE HYDRAULIC DRIVE	27	01
14	0571015448	DRIVE AXLE		01
15	0501069017	12Z GEAR		01
16	0521063041	GEAR 23Z		01
17	0571015189	PRISONER 3/8"		03
18	0503017021	M8 X 0.5" BOLT		01
19	0503010025	3/8 SPRING WASHER		07
20	0503010026	3/8" NUT		05
21	0521058094	SUPPORT HOSE	33	01
22	0521066606	OIL TUBE		02
23	0571015450	CHAIN CAP		01
24	0503010386	CABLE		03
25	0531011180	UPPER BODY CLIP		04
26	0503010180	7/16" SPRING WASHER		04
27	0503011102	BOLT 7/16 UNC X 1.1/4 C S G.5 ZN		04
28	0503010920	1/2 UNC X 1.1/2 C S G.5 ZN BOLT		02
29	0503010019	1/2" SPRING WASHER		02



**DCA2 7500 MC WITH HYDRAULIC OPERATION**  
**HYDRAULIC DRIVE ASSY**

Page 23  
0521057956

<b>Item</b>	<b>Code</b>	<b>Description</b>	<b>See page</b>	<b>QT</b>
30	0503010060	1/2 UNC G.5 ZN HEX NUT		02
31	0503010849	3/8" X 1-1/2" BOLT		04
32	0501010984	10,50 X 27 X 3,00 FLAT WASHER		06
33	0521057978	SIMPLE HYDRAULIC ACTUATION HOSE SET	31	01
34	0501053834	MALE QUICK COUPLER	32	02
35	0581011125	LOCK WASHER		01

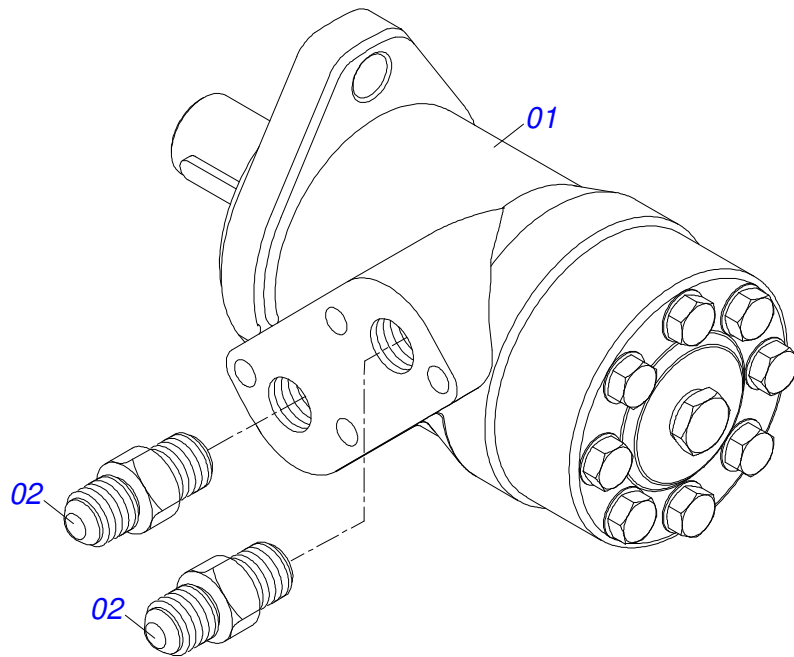

Item	Code	Description	See page	QT
01	0503016055	PARKER OMP 80 ISOBUS HYDRAULIC MOTOR		01
02	0511014065	7/8" NF X R1/2NPT X 52 NIPPLE		02

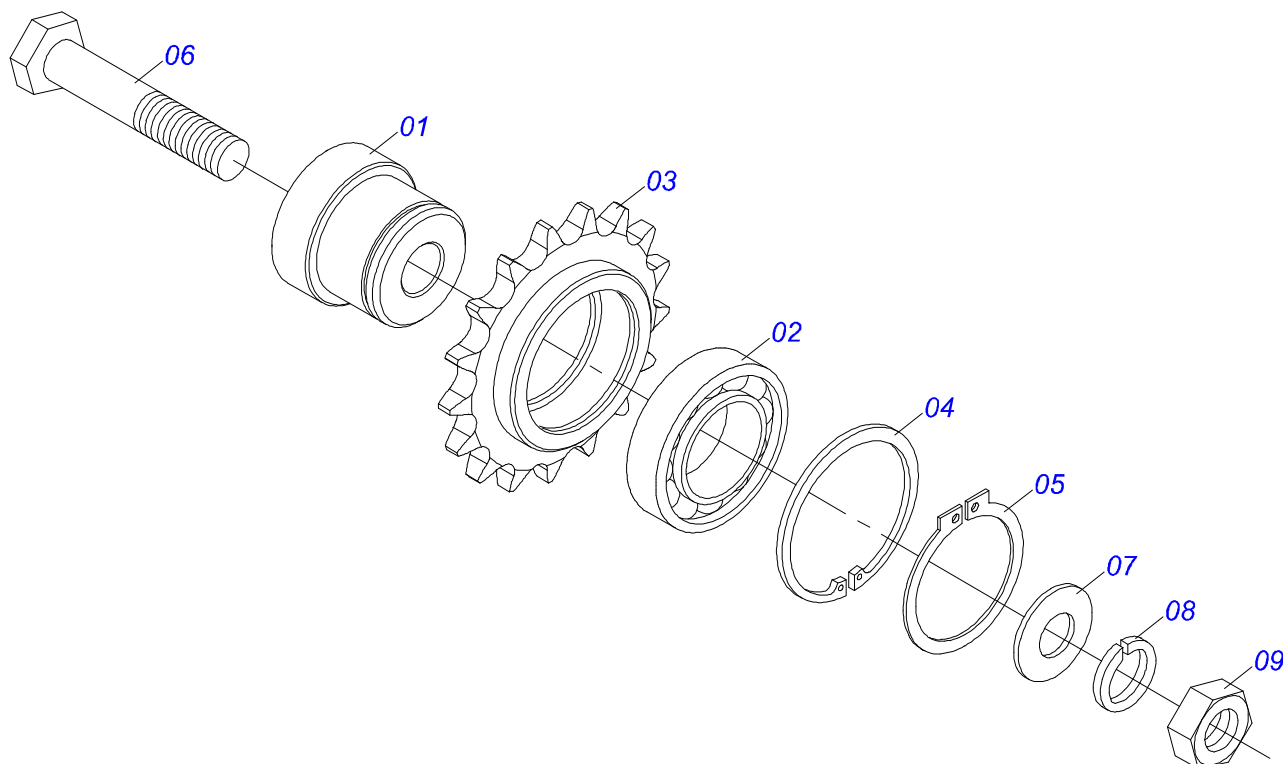

Item	Code	Description	See page	QT
01	0571015185	AXLE TIGHTENER 26		01
02	0503011410	ROLLER BEARING		01
03	0511061836	17Z GEAR		01
04	0503011105	SEAL RING		01
05	0503010406	501025 CLAMPING RING (FOR AXLE)		01
06	0501010096	3/8" X 2" BOLT		01
07	0501010984	10,50 X 27 X 3,00 FLAT WASHER		01
08	0503010025	3/8 SPRING WASHER		01
09	0503010026	3/8" NUT		01

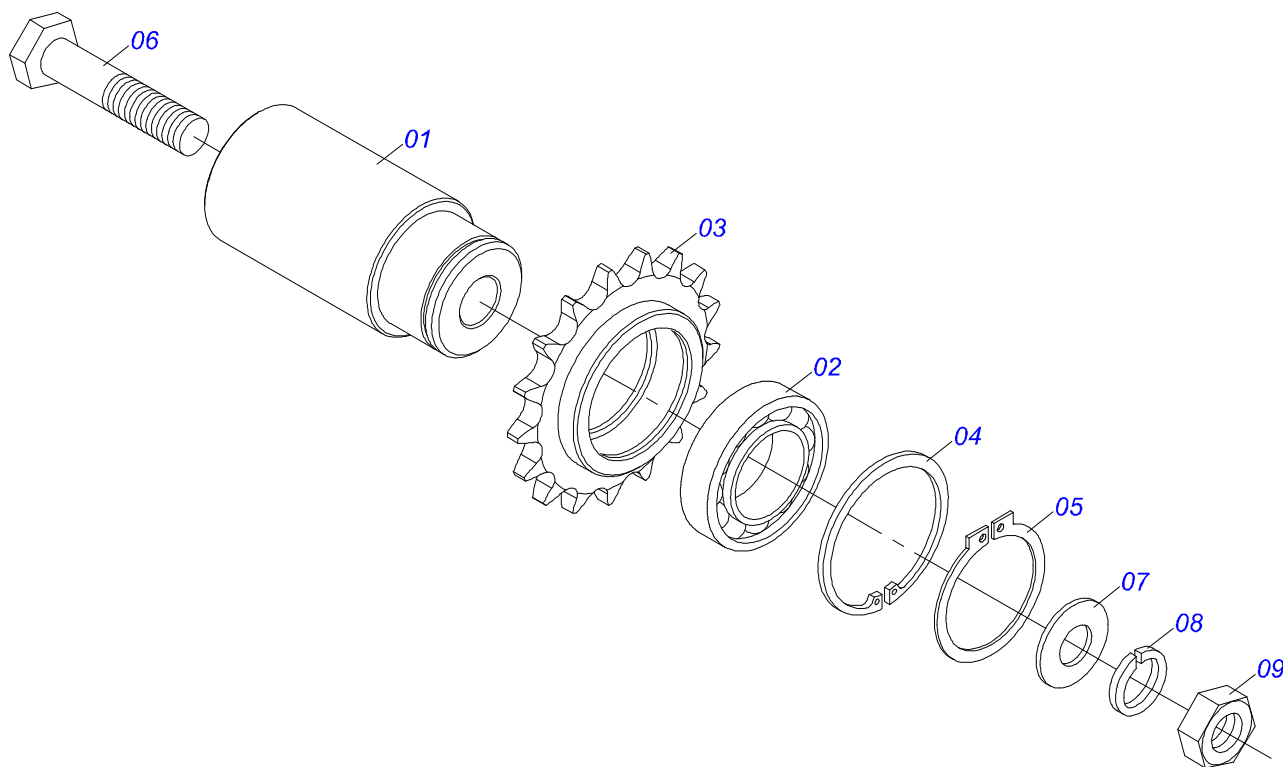

Item	Code	Description	See page	QT
01	0571015186	AXLE TIGHTENER 26		01
02	0503011410	ROLLER BEARING		01
03	0511061836	17Z GEAR		01
04	0503011105	SEAL RING		01
05	0503010406	501025 CLAMPING RING (FOR AXLE)		01
06	0503010718	3/8" X 3-1/2" BOLT		01
07	0501010984	10,50 X 27 X 3,00 FLAT WASHER		01
08	0503010025	3/8 SPRING WASHER		01
09	0503010026	3/8" NUT		01



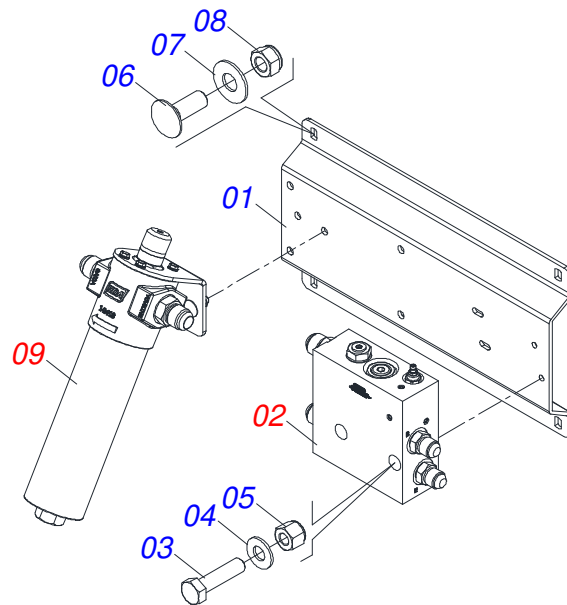

Item	Code	Description	See page	QT
01	0591013644	SUPPORT SET HIDRAULICO		01
02	0521057953	BLOCK HYDAC	28	01
03	0503011766	5/16" X 2-1/2" BOLT		02
04	0501010694	FLAT WASHER 32,50 X 75 X 4,75		02
05	0503013759	NUT		02
06	0501011643	3/8 X 1" BOLT		04
07	0501013518	FLAT WASHER		04
08	0503013357	3/8 SELF-ADJUSTING NUT		04
09	0521057952	FILTER PRES PARKER HDA FP20 10FV 06B LV6	29	01

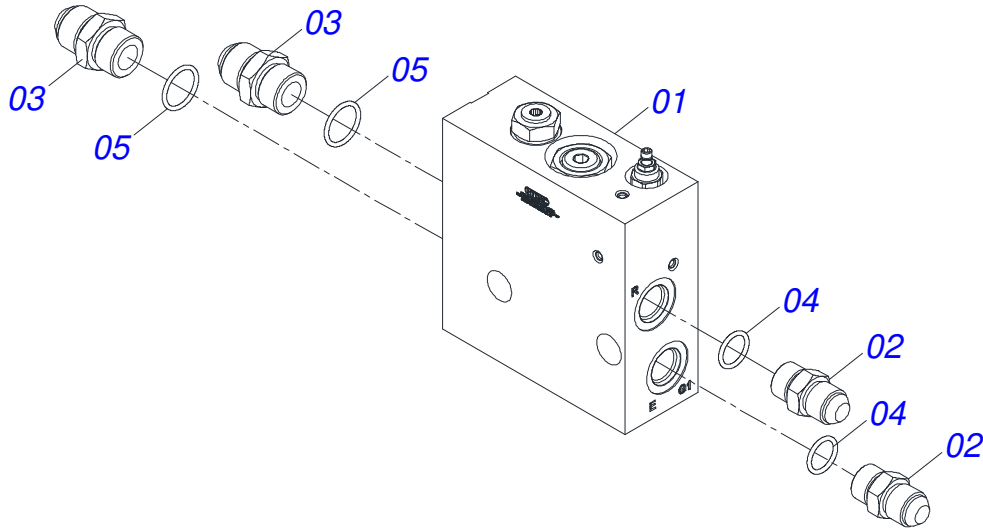

Item	Code	Description	See page	QT
01	0503063271	BLOCK		01
02	0501010590	NIPPLE		02
03	0501010589	R. 1.1/16UN SEXT 1.1/4 X 52 NIPPLE		02
04	0503010045	O'RING		02
05	0503011109	O'RING 2-119 N 3006 9B		02

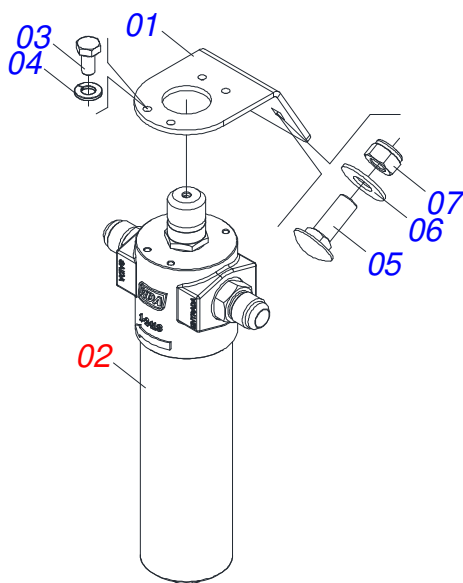

Item	Code	Description	See page	QT
01	0591013645	PRESSURE FILTER SUPPORT		01
02	0521057599	FILTER PRESS PARKER HDA FP20 10FV 06B LV6 30 WITH NIPPLE		01
03	0503011812	BOLT M6 X 1 X 12 CS 8.8 ZN		04
04	0503010143	1/4" SPRING WASHER		04
05	0501011643	3/8 X 1" BOLT		02
06	0501013518	FLAT WASHER		02
07	0503013357	3/8 SELF-ADJUSTING NUT		02

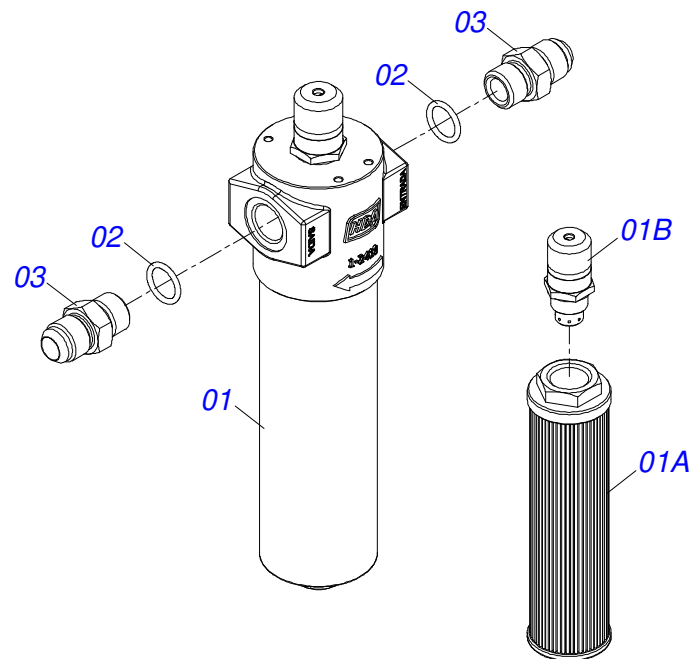

Item	Code	Description	See page	QT
01	0503063077	PRESSURE FILTER PARKER HDA FP20 10FV 06B LV6		01
01A	0503035357	FILTERING ELEMENT FOR PRESSURE FILTER		01
01B	0503019963	DIRT PRESSURE LINE INDICATOR		01
02	0503010605	O'RING		02
03	0591012696	NIPPLE 3/4 BSP X 1.1/16 UNF		02

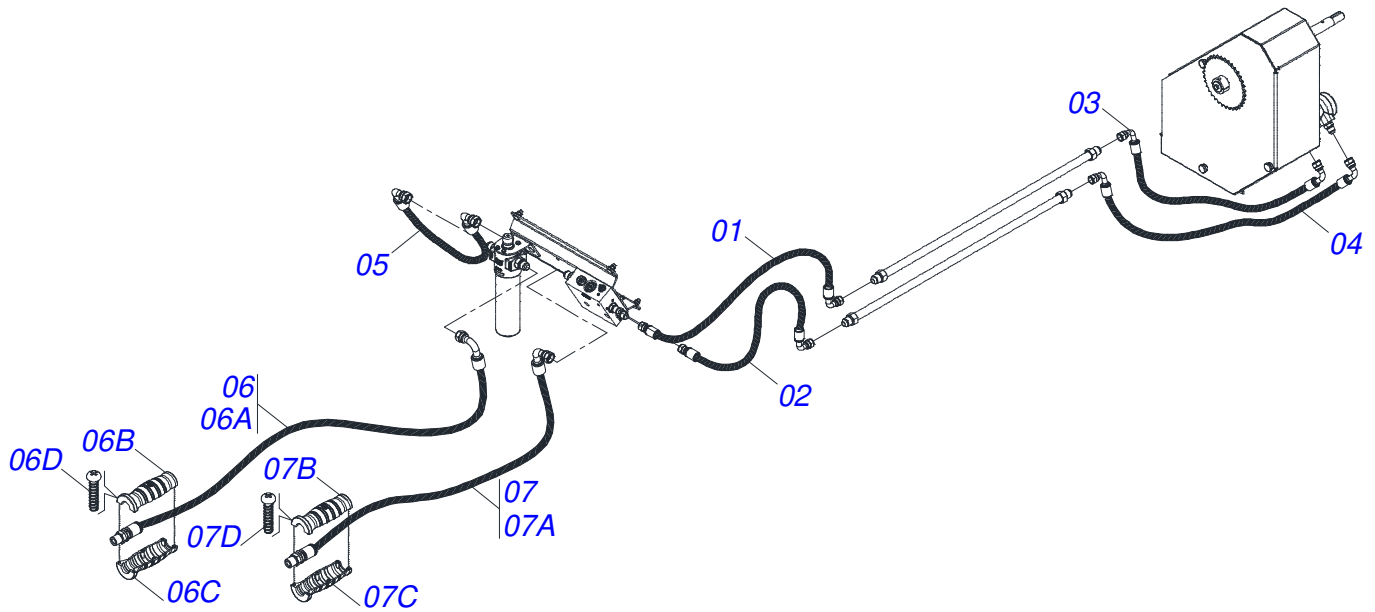

Item	Code	Description	See page	QT
01	0501081235	1/2 X 650 TR- TC HOSE		01
02	0501080218	1/2 X 750 HOSE		01
03	0501082303	HOSE 1/2 X 930 TC-TC 90G		01
04	0501082304	1/2 X 1000 TR-TC HOSE		01
05	0501081365	HOSE 3/4 X 680 TC-TC 180G		01
06	0521057977	HOSE 3/4 X 2100 TC-TM AMARILLO/AZUL		01
06A	0501082295	HOSE 3/4 X 2100 TC - TM R.1/2NPT		01
06B	0503034493	HYDRAULIC HOSE DEPTH (YELLOW)		01
06C	0503034494	HYDRAULIC HOSE GRIP (BLUE)		01
06D	0503018952	PH 2,5 X 10 ZB PLASTIC BOLT		06
07	0521057976	HOSE 3/4 X 2100 TC-TM YELLOW/RED		01
07A	0501082295	HOSE 3/4 X 2100 TC - TM R.1/2NPT		01
07B	0503034493	HYDRAULIC HOSE DEPTH (YELLOW)		01
07C	0503034495	HYDRAULIC HOSE GRIP (RED)		01
07D	0503018952	PH 2,5 X 10 ZB PLASTIC BOLT		06

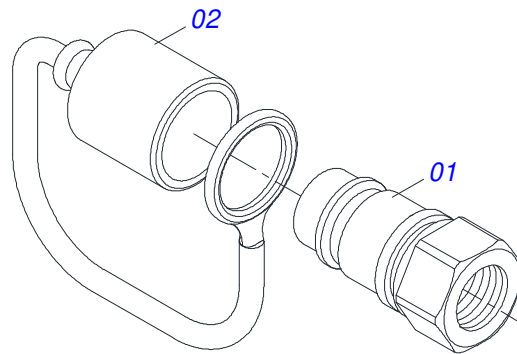

Item	Code	Description	See page	QT
01	0503011627	MALE QUICK COUPLER AGR 1/2 NPT		01
02	0503011882	MALE QUICK COUPLER CAP		01

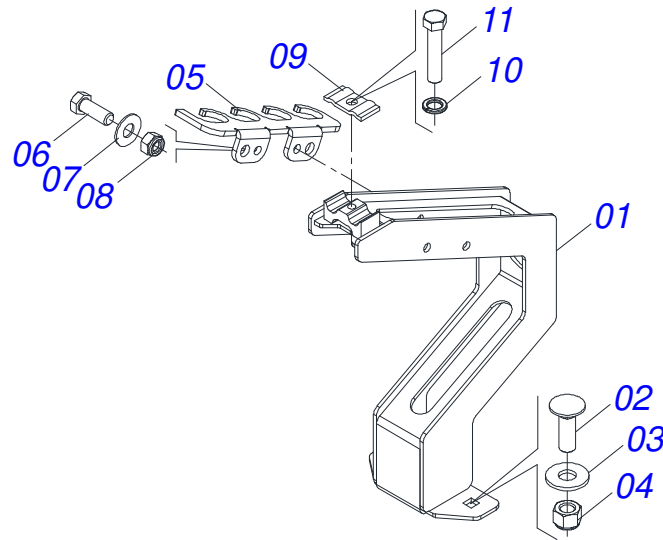

Item	Code	Description	See page	QT
01	0531060944	HOSE HOLDER ASSY		01
02	0503014378	1/2" X 1-1/2" BOLT		02
03	0511017302	FLAT WASHER 13,50 X 32,50 X 3,0 ZN		02
04	0503010589	UNC SELF ADJUSTING NUT 1/2" UNC ALTA G.5 ZN		02
05	0591018556	HOSE FIXER ASSY		01
06	0503011087	3/8" X 1" BOLT		02
07	0501013518	FLAT WASHER		02
08	0503013357	3/8 SELF-ADJUSTING NUT		02
09	0531011180	UPPER BODY CLIP		01
10	0503010180	7/16" SPRING WASHER		01
11	0503011173	7/16" X 2" BOLT		01

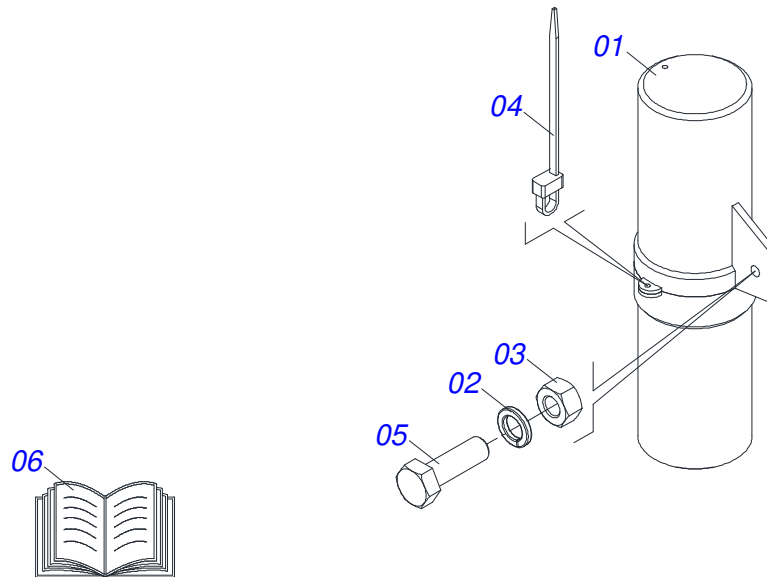

Item	Code	Description	See page	QT
01	0503060100	SUPPORT INSTRUCTION MANUAL		01
02	0503010179	LOCK WASHER 5/16 ZN 1K01528		01
03	0503010337	NUT 5/16 UNC G.5 ZN		01
04	0503010267	NYLON CLAMP 3,60 X 1,3 X 155 MM		01
05	0503010363	BOLT 5/16 UNC X 1 C S G.2 ZN		01
06	0501032417	BAG WITH INSTRUCTION MANUAL/CATALOG		01



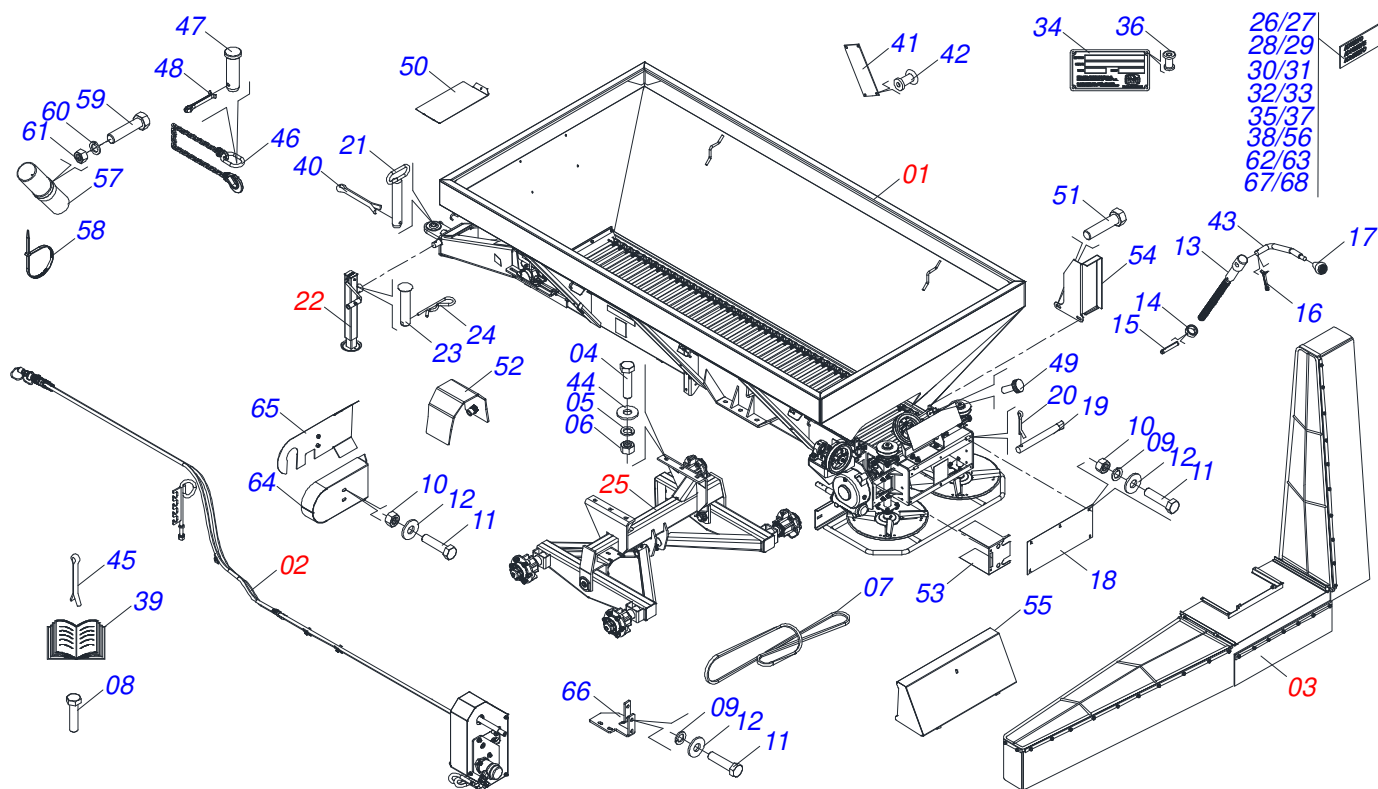

Item	Code	Description	See page	QT
01	0511054505	FRAME WITH BUCKET	3	01
02	0511054498	HYDRAULIC CONTROL KIT	36	01
03	0531051665	DAMPER	37	01
04	0503010899	5/8 UNC X 2.1/4 BOLT		06
05	0503010027	5/8 SPRING WASHER		06
06	0503010013	5/8" UNC G.5 ZN HEX NUT		06
07	0503010154	C-128 BELT		01
08	0503010751	C3/8" X 1.1/4" HEX BOLT G.5		02
09	0503010025	3/8 SPRING WASHER		14
10	0503010026	3/8" NUT		12
11	0503010237	3/8" X 1" BOLT		12
12	0501010984	10,50 X 27 X 3,00 FLAT WASHER		15
13	0561014861	REGULATOR		01
14	0511013015	SLEEVE		01
15	0503010561	SPRING PIN		01
16	0503010257	1/8" X 1" SPLIT PIN		01
17	0503030878	LEVER CRANK		01
18	0501019460	REAR PROTECTION		01
19	0501017574	0.3" X 2.7" AXLE		02
20	0503010140	1/8" X 3/4" SPLIT PIN		02
21	0501069080	COUPLING SHAFT		01
22	0503062157	DRAWBAR JACK	17	01
23	0521010549	COUPLING SHAFT		01
24	0503030168	HITCH PIN CLIP		01
25	0521046046	FIXING STAND ASSY	18	01
26	0503034641	ADHESIVE LABEL		02
27	0503031859	ADHESIVE LABEL DANGER		02
28	0503031809	ADHESIVE LABEL		01
29	0503031428	READ MANUAL DECAL		01
30	0503031827	LUBRICATE AND RETIGHTEN DAILY DECAL		01

Item	Code	Description	See page	QT
31	0503031818	ADHESIVE LABEL		01
32	0503031087	AUTO CONTROL APPROVED DECAL		01
33	0503032425	ADHESIVE LABEL ATTENTION		01
34	0503034003	61 X 118 SERIAL NUMBER TAG		01
35	0503032949	ATTENTION 3 LANGUAGES DECAL		01
36	0503010001	RIVET 3,2 X 5,5		04
37	0503031427	ADHESIVE LABEL		01
38	0503031565	CAUTION TRANSPORTATION DECAL		01
39	0501032417	BAG WITH INSTRUCTION MANUAL/CATALOG		01
40	0503010534	3/8" X 2.1/2" SPLIT PIN		01
41	0503030751	REGULATOR PLATE		01
42	0503012209	RIVET POP		04
43	0521011107	CRANK BODY		01
44	0501012140	FLAT WASHER 16,50 X 40 X 4,00 ZN		12
45	0503010131	3/16" X 1.1/2" SPLIT PIN		04
46	0503013150	1300 X 3/8" CHAIN		01
47	0581011220	COUPLING SHAFT		01
48	0503010131	3/16" X 1.1/2" SPLIT PIN		01
49	0503010386	CABLE		01
50	0581017493	FRONT PROTECTION		01
51	0503010849	3/8" X 1-1/2" BOLT		06
52	0521068819	PULLEY AXLE PROTECTION		01
53	0581017497	COUPLING PROTECTION		01
54	0581017492	SIDE PROTECTION BELT		01
55	0501069840	REAR COVER PROTECTION		01
56	0503034648	ADHESIVE LABEL		01
57	0503060100	SUPPORT INSTRUCTION MANUAL		01
58	0503010267	NYLON CLAMP 3,60 X 1,3 X 155 MM		01
59	0503010363	BOLT 5/16 UNC X 1 C S G.2 ZN		01
60	0503010179	LOCK WASHER 5/16 ZN 1K01528		01
61	0503010337	NUT 5/16 UNC G.5 ZN		01
62	0503031739	DANGER DECAL		01
63	0503034640	ADHESIVE LABEL		02
64	0581017500	REAR LATERAL PROTECTION BELT		01
65	0521068820	REAR LATERAL PROTECTION BELT		01
66	0521068821	SUPPORT BELT PROTECTION		01
67	0503035157	ADHESIVE LABEL DISTRIBUTOR LIMESTONE		01
68	0503036144	MAXIMUM SPEED ADHESIVE LABEL		01

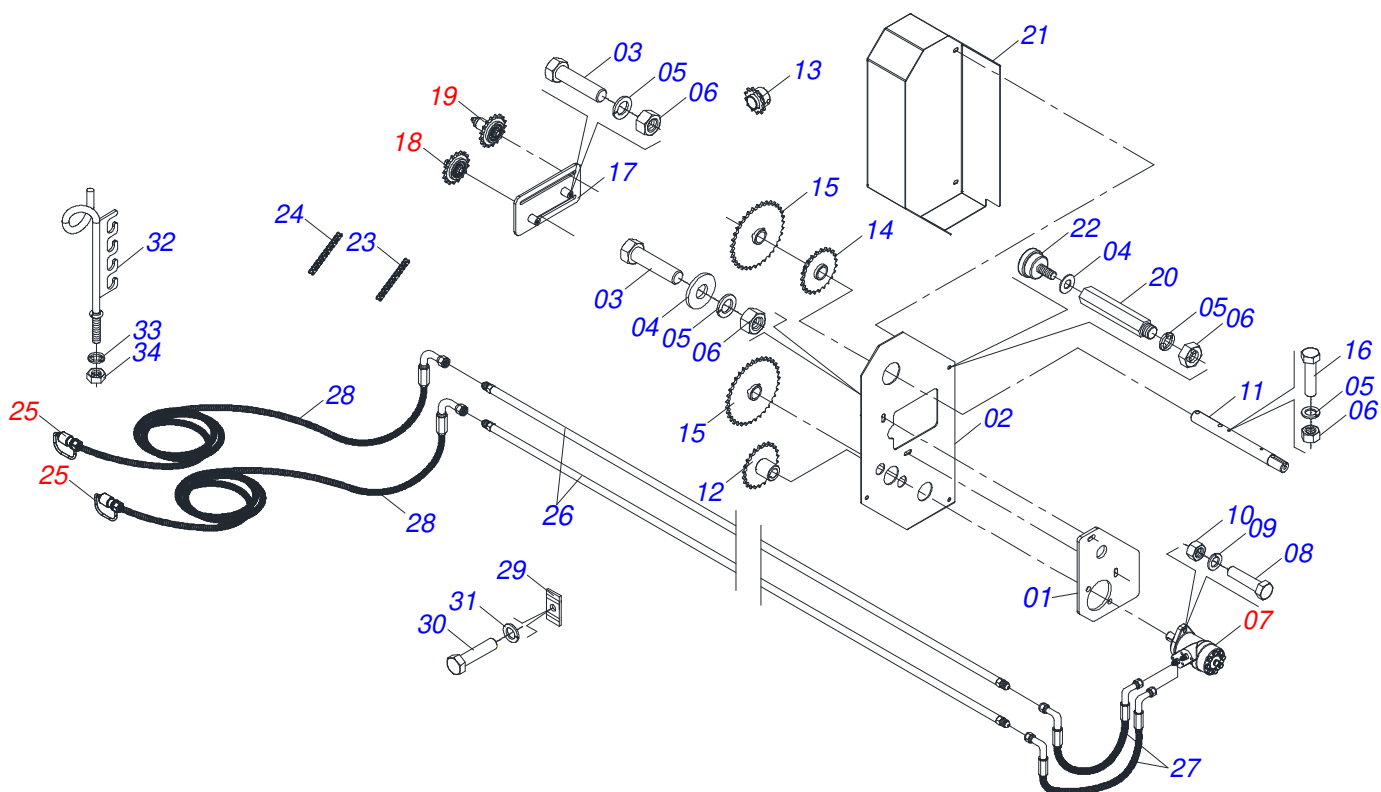

Item	Code	Description	See page	QT
01	0571015182	HIDRAULIC MOTOR SUPPORT		01
02	0571015447	PROTECTION REAR		01
03	0503010751	C3/8" X 1.1/4" HEX BOLT G.5		05
04	0501010984	10,50 X 27 X 3,00 FLAT WASHER		08
05	0503010025	3/8 SPRING WASHER		10
06	0503010026	3/8" NUT		07
07	0511053588	MOTOR HYDRAULIC OMP 80 WITH NIPPLE 7/8 24 NIPPE 7/8		01
08	0503010920	1/2 UNC X 1.1/2 C S G.5 ZN BOLT		02
09	0503010019	1/2" SPRING WASHER		02
10	0503010060	1/2 UNC G.5 ZN HEX NUT		02
11	0571015448	DRIVE AXLE		01
12	0521064566	GEAR HIDRAULIC MOTOR		01
13	0501069017	12Z GEAR		01
14	0521063041	GEAR 23Z		01
15	0501069020	35Z GEAR		02
16	0503011268	3/8" X 2-1/2" BOLT		03
17	0521064691	SUPPORT TENSIONER		01
18	0511054496	TENSIONER SMALEER ASSY	25	01
19	0511054497	TENSIONER LARGER ASSY	26	01
20	0571015189	PRISONER 3/8"		03
21	0571015450	CHAIN CAP		01
22	0503010386	CABLE		03
23	0503011233	50-1 CHAIN X 79 LINK + REDUCTION + MENDING		01
24	0503013003	50-1 CHAIN X 79 LINK + REDUCTION + MENDING		01
25	0501053834	MALE QUICK COUPLER	32	02
26	0521064594	OIL TUBE DISTRIBUTOR		02
27	0501081512	HOSE 1/2 X 800 TC-TC 90G		02
28	0501080246	TR-TM HOSE ASSY		02
29	0531011180	UPPER BODY CLIP		04



**DCA2 7500 MC WITH HYDRAULIC OPERATION**  
**HYDRAULIC CONTROL KIT**

Page 36  
0511054498

<b>Item</b>	<b>Code</b>	<b>Description</b>	<b>See page</b>	<b>QT</b>
30	0503012555	SCREW 7/16 UNC X 2 CS RT G.7 ZN		04
31	0503010180	7/16" SPRING WASHER		04
32	0501060409	HOSE SUPPORT ASSY		01
33	0503010023	3/4" SPRING WASHER		01
34	0503010014	3/4" ZN G.5 (HEAVY) UNC HEX NUT		01

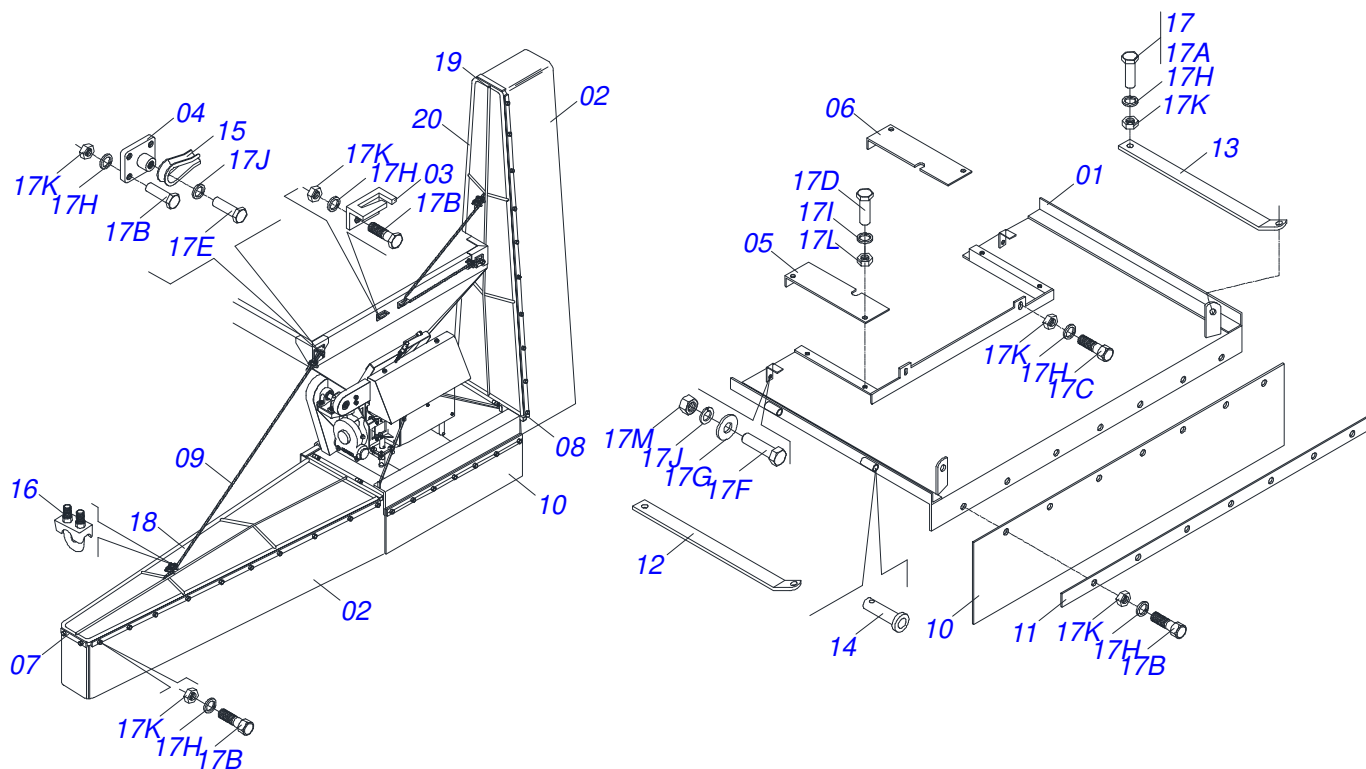

Item	Code	Description	See page	QT
01	0501067801	CENTRAL FRAME		01
02	0511013808	BLANKET RUBBER		02
03	0501066514	STELL GUIDE CABLO		02
04	0501066515	STELL SUPPORT CABLO		02
05	0511017104	RIGHT COVER SIDE		01
06	0511017105	LEFT COVER SIDE		01
07	0511013806	FIXER CANVAS RIBBON		02
08	0511013793	FIXER SUPPORT CANVAS		04
09	0511013817	STELL CABLE		02
10	0511013810	REAR PROTECTION		01
11	0511013804	REAR RIBBON FIXER BLANKET		01
12	0511017465	ATTACHMENT BAR		01
13	0511017466	ATTACHMENT BAR		01
14	0511013803	PIN		04
15	0503011202	BRACKET		04
16	0503010165	5/16" CABLO STEEL STAPLE		08
17	0501032349	PACKED PARTS		01
17A	0503010256	3/8" X 3/4" BOLT		04
17B	0503010237	3/8" X 1" BOLT		65
17C	0501010080	3/8" BOLT		02
17D	0503011102	BOLT 7/16 UNC X 1.1/4 C S G.5 ZN		04
17E	0503010834	1/2 X 1 BOLT		02
17F	0501010063	1/2" X 1-1/2" BOLT		02
17G	0511017302	FLAT WASHER 13,50 X 32,50 X 3,0 ZN		04
17H	0503010025	3/8 SPRING WASHER		71
17I	0503010180	7/16" SPRING WASHER		04
17J	0503010019	1/2" SPRING WASHER		04
17K	0503010026	3/8" NUT		71
17L	0503010244	7/16" NUT		04
17M	0503010060	1/2 UNC G.5 ZN HEX NUT		02



Item	Code	Description	See page	QT
18	0501066442	RIGHT WING		01
19	0501066443	LEFT WING		01
20	0511013809	SUPPORT PROTECTION		02

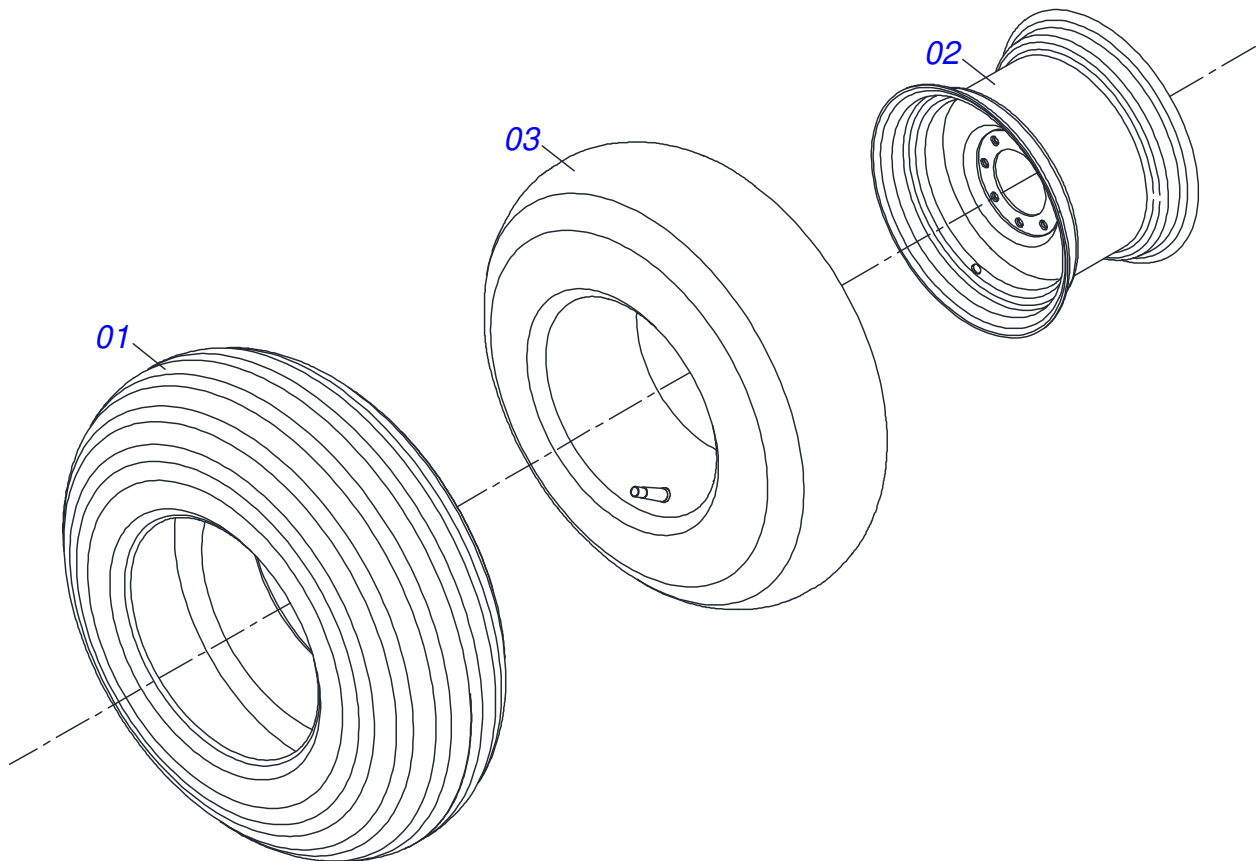

Item	Code	Description	See page	QT
01	0503010858	CANVAS TIRE		01
02	0503011468	WEEL		01
03	0503010860	AIR CHAMBER 11L 15		01







**MARCHESAN**

***Technical Publications | Elaboration and Revision***

LORENA ROCHA ALVES

[www.marchesan.com.br](http://www.marchesan.com.br)

