

ROTARY CUTTERS

RO2 1700 WITH WHEEL

Code: 0501093058
Series: S-0615
Revision: 00
Date Revision: AGOSTO/2021

PARTS CATALOGUE



MARCHESAN



PRODUCTS

Code	Description
0104010053	RO2 1700 C/R C/PROT CORRENTE S-0615
0104010050C	RO2 1700 C/R S/PROT EXP S-0615

ATTENTION: IMPORTANT

Marchesan S.A. reserves the right to improve and / or modify the technical features of its products, without obligation to do the same with those products already sold and without prior knowledge of the dealer or the consumer.



INDEX

0909092956	ASY FRAME	1
0511056723	SEMIFINISHED FRAME	2
0511056721	SEMIFINISHED FRAME	3
0511043567	ROTARY CUTTERS HUB ASSY	4
0501056337	SUPPORT	5
0909094988	HEAD ASSY	6
0521051864	DOOR ASSY INSTRUCTION MANUAL	7
0909094987	SKID ASSY	8
0511047301	CARRYING WHEELS ASSY	9
0501047946	DRIVE SHAFT	10
0521050680	FRONT CURRENT PROTECTION (1805)	11
0521050679	REAR CURRENT PROTECTION (910)	12
0511058384	MULTIPLIER WITH SUPPORT	13
0501046851	MULTIPLIER	14

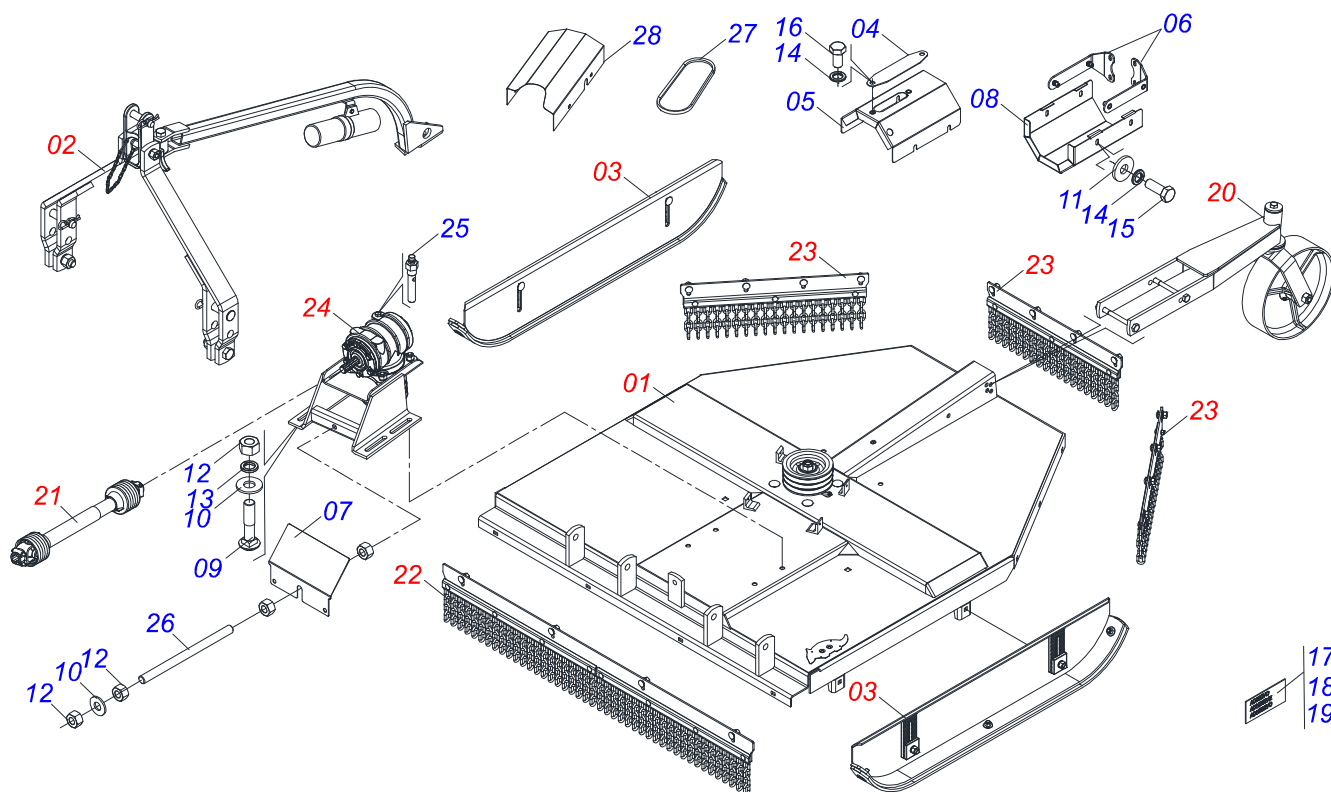

Item	Code	Description	See page	QT
01	0511056723	SEMIFINISHED FRAME	2	01
01.	0511056721	SEMIFINISHED FRAME	3	01
02	0909094988	HEAD ASSY	6	01
03	0909094987	SKID ASSY	8	01
04	0581012546	LUBRICATION AXIS TRANSMISSION		01
05	0501110998	CARDAN TOP PROTECTION COVER		01
06	0501110996	LOWER SUPPORT COVER PROTECTION WITH RIVET		02
07	0531012083	PROTECTION CHAIN FIXER MULTIPLIER		01
08	0581011777	BODY LOWER PROTECTION COAT		01
09	0501010162	3/4" X 4" BOLT		04
10	0501010322	FLAT WASHER		07
11	0501010984	FLAT WASHER		08
12	0503010014	3/4" NUT		11
13	0503010023	3/4" SPRING WASHER		07
14	0503010025	3/8" SPRING WASHER		10
15	0503010237	3/8" X 1" BOLT		04
16	0503010256	3/8" X 3/4" BOLT		06
17	0503031087	ADHESIVE LABEL		01
18	0503031127	ADHESIVE LABEL		01
19	0503034247	ADHESIVE LABEL POINT LUBRICATION		02
20	0511047301	CARRYING WHEELS ASSY	9	01
21	0501047946	DRIVE SHAFT	10	01
22	0521050680	FRONT CURRENT PROTECTION (1805)	11	01
23	0521050679	REAR CURRENT PROTECTION (910)	12	03
24	0511058384	MULTIPLIER WITH SUPPORT	13	01
25	0501110186	OIL SMALLER LEVEL INDICATOR		01
26	0501016413	362 TENSIONER BODY		01
27	0503010153	C-51 BELT		03
28	0521066331	PROTECTION COVER OF THE BELT		01

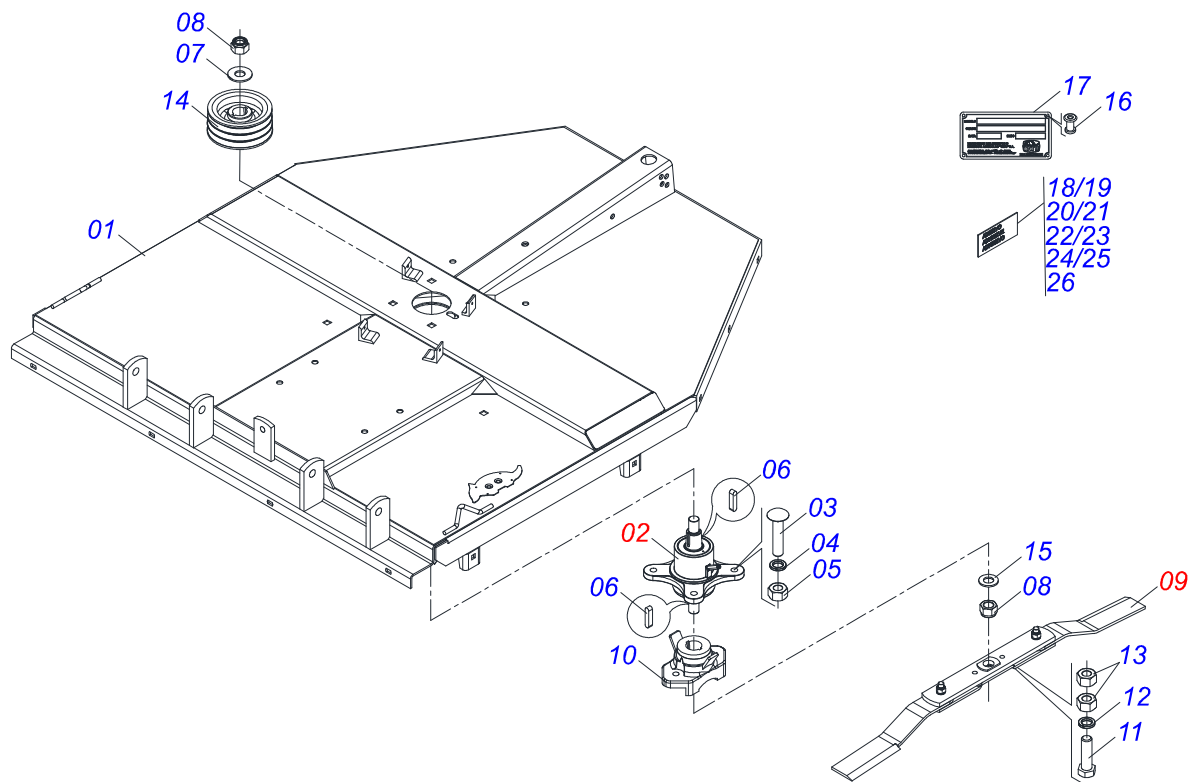

Item	Code	Description	See page	QT
01	0521065600	FRAME		01
02	0511043567	ROTARY CUTTERS HUB ASSY	4	01
03	0503013122	3/4 UNC X 4.1/4 CAPQ G.5 ZNBOLT		04
04	0503011442	3/4" SPRING WASHER		04
05	0503010014	3/4" NUT		04
06	0501010536	KEYWAY SQUARE		02
07	0561015762	FLAT WASHER		01
08	0503010817	1.1/4" SELF LOCKING NUT		02
09	0501056337	SUPPORT	5	01
10	0502012453	SUPPORT FLANGE		01
11	0503011328	3/4" X 4" BOLT		02
12	0503011442	3/4" SPRING WASHER		02
13	0503010014	3/4" NUT		04
14	0502011377	REEL 190 X 50 PULLEY		01
15	0501017779	32 X 60 X 4.75 FLAT WASHER		01
16	0503034003	SERIAL NUMBER TAG 61 X 118		01
17	0503010001	3.2 X 5.5 RIVET		04
18	0503031427	ADHESIVE LABEL		01
19	0503031428	READ MANUAL DECAL		01
20	0503031929	ADHESIVE LABEL		01
21	0503031930	ADHESIVE LABEL		01
22	0503031931	ADHESIVE LABEL		01
23	0503032949	ADHESIVE LABEL		01
24	0503034078	LIFTING POINTS DECAL		01
25	0503034333	ADHESIVE LABEL		01
26	0503034451	ADHESIVE LABEL		01

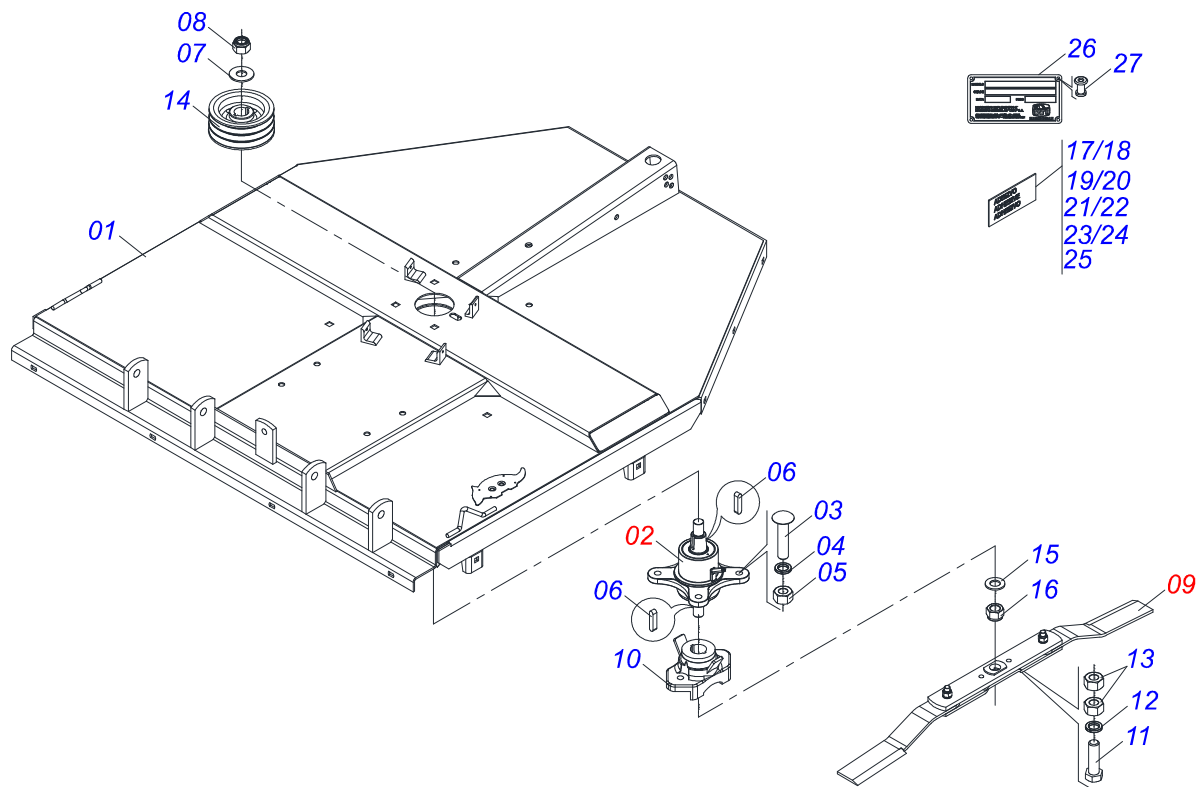

Item	Code	Description	See page	QT
01	0521065600	FRAME		01
02	0511043567	ROTARY CUTTERS HUB ASSY	4	01
03	0503013122	3/4 UNC X 4.1/4 CAPQ G.5 ZNBOLT		04
04	0503011442	3/4" SPRING WASHER		04
05	0503010014	3/4" NUT		04
06	0501010536	KEYWAY SQUARE		04
07	0561015762	FLAT WASHER		01
08	0503010817	1.1/4" SELF LOCKING NUT		01
09	0501056337	SUPPORT	5	01
10	0502012453	SUPPORT FLANGE		01
11	0503011328	3/4" X 4" BOLT		02
12	0503011442	3/4" SPRING WASHER		02
13	0503010014	3/4" NUT		04
14	0502011377	REEL 190 X 50 PULLEY		01
15	0501017779	32 X 60 X 4.75 FLAT WASHER		01
16	0503010817	1.1/4" SELF LOCKING NUT		01
17	0503031931	ADHESIVE LABEL		02
18	0503031930	ADHESIVE LABEL		01
19	0503031087	ADHESIVE LABEL		01
20	0503031929	ADHESIVE LABEL		01
21	0503031428	READ MANUAL DECAL		01
22	0503031427	ADHESIVE LABEL		01
23	0503031127	ADHESIVE LABEL		01
24	0503060902	SET LABEL ADHESIVE		01
25	0503032949	ADHESIVE LABEL		01
26	0503034003	SERIAL NUMBER TAG 61 X 118		01
27	0503010001	3.2 X 5.5 RIVET		04

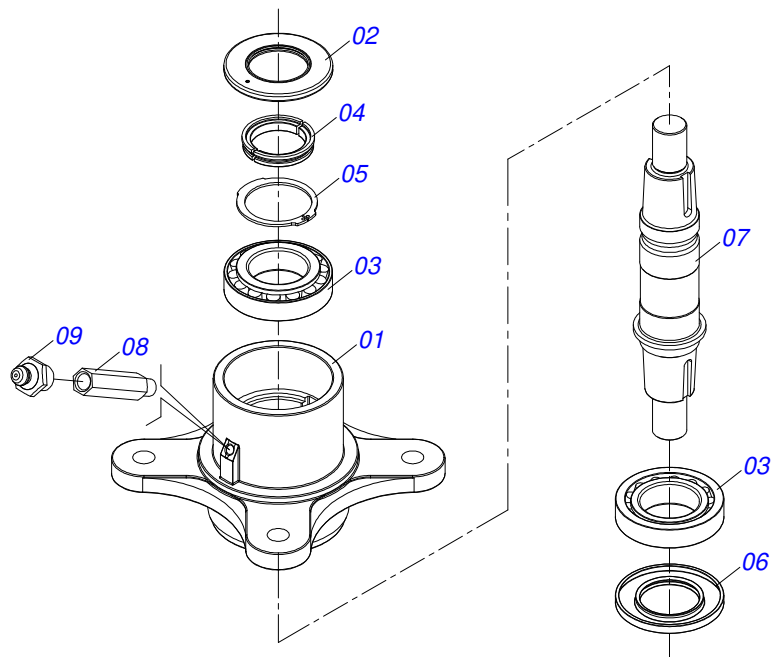

Item	Code	Description	See page	QT
01	0502012294	DROP HUB		01
02	0503013201	ARCA 6016 BRG SEAL		01
03	0503012418	32211 ROLLER BEARING		02
04	0541014445	LOCK RING		01
05	0503012311	501065 RENO RING		01
06	0503013211	6016 BRG SEAL		01
07	0541014095	ROTARY CUTTERS SMALLER AXLE		01
08	0501019757	EXTENSION GREASE FITTING		01
09	0503010002	1800 GREASE FITTING		01

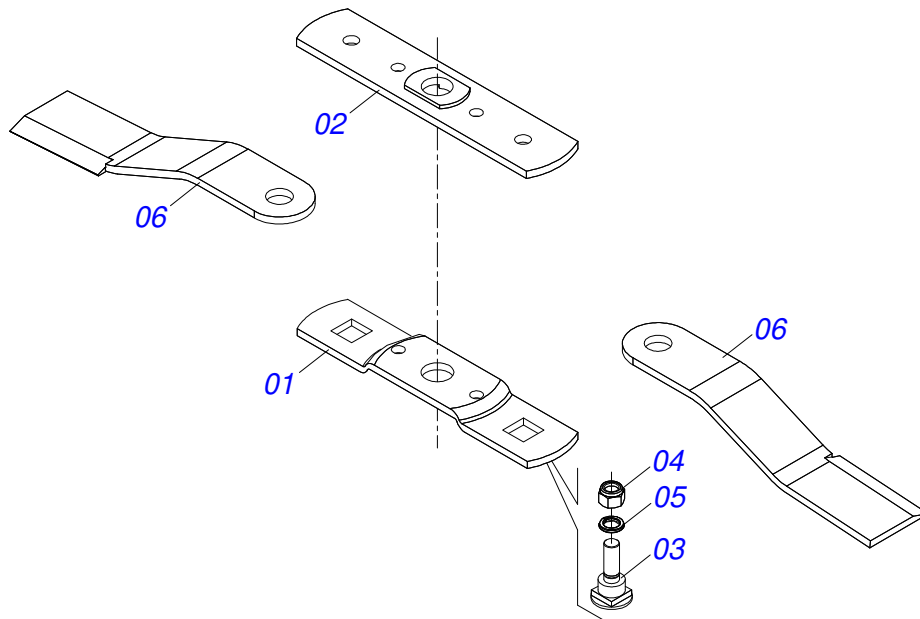

Item	Code	Description	See page	QT
01	0561017369	ROTARY LOWER SUPPORT LOWER		01
02	0561017307	SUPPORT UPPER BASE		01
03	0511019000	BOLT		02
04	0503010812	7/8" UNF SELF LOCKING NUT		02
05	0503011447	SPRING WASHER		02
06	0622400054	24.5" X 3.94" X 0.5" ROTARY CUTTER		02

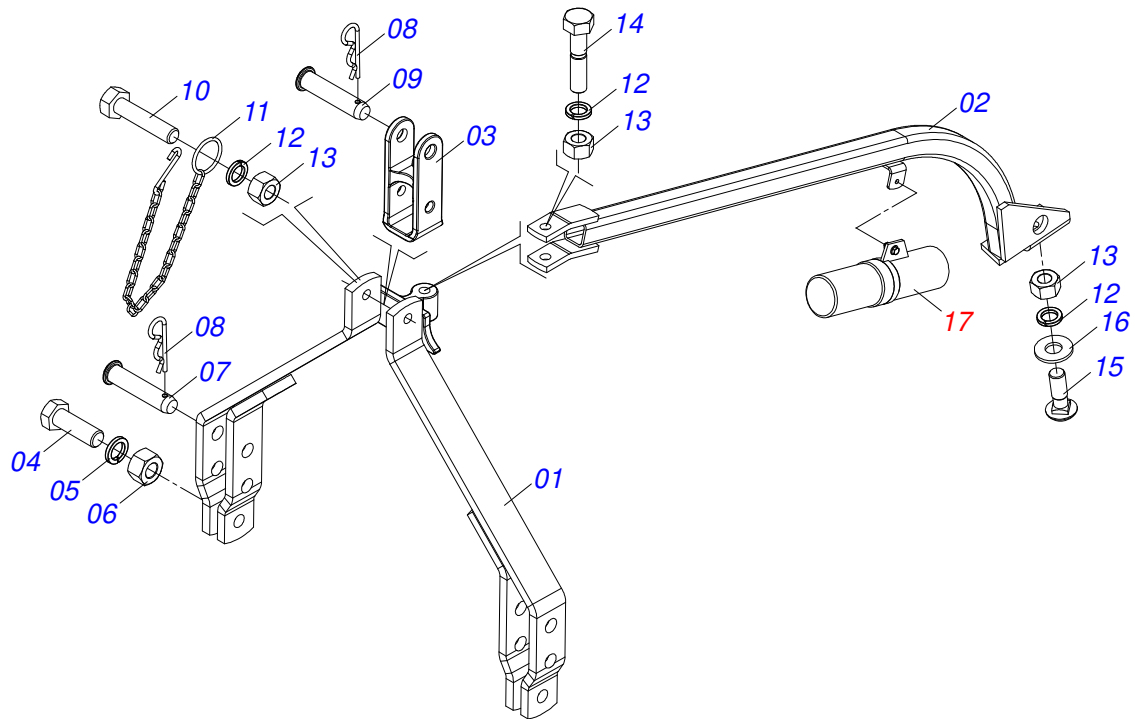

Item	Code	Description	See page	QT
01	0501067832	DRAWBAR		01
02	0521066524	ATTACHMENT BAR		01
03	1902040922	ROTARY COTTERS HEAD SUPPLEMENT		01
04	0503011432	BOLT		02
05	0503010012	1" SPRING WASHER		02
06	0501010059	1.5/8 NUT		02
07	0521010596	COUPLING SHAFT		02
08	0503031035	HAIR PIN		03
09	0521010578	COUPLING SHAFT		01
10	0503011198	C3/4" X 6" SCREW		01
11	0503011981	17.7" CHAIN WITH HOOK/LINK		02
12	0503010023	3/4" SPRING WASHER		03
13	0503010014	3/4" NUT		03
14	0501010216	3/4" X 4-1/2" BOLT		01
15	0501017305	3/4" X 2-1/4" BOLT		01
16	0501010322	FLAT WASHER		01
17	0521051864	DOOR ASSY INSTRUCTION MANUAL	7	01

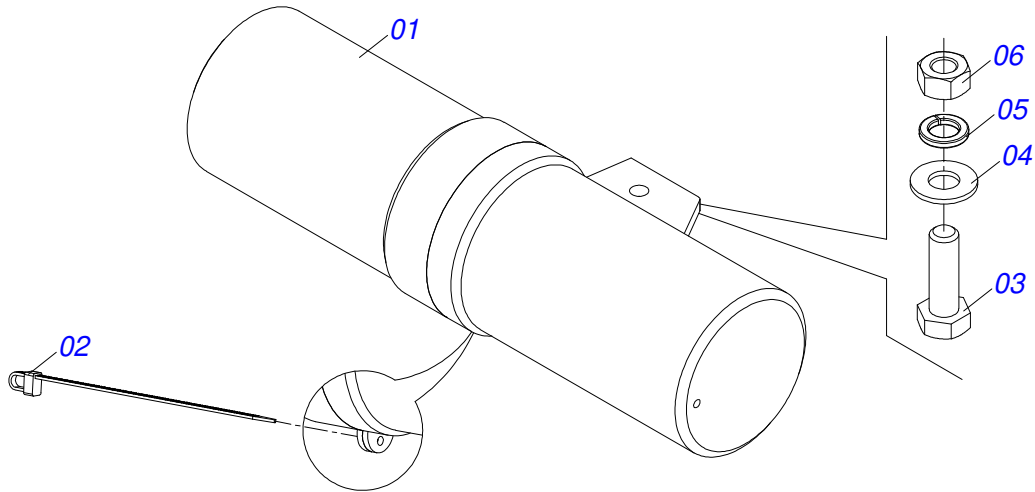

Item	Code	Description	See page	QT
01	0503060100	OPERATOR'S MANUAL STORAGE TUBE		01
02	0503010267	NYLON CLAMP		01
03	0503010363	5/16" X 1" BOLT		01
04	0501010694	8.5 X 18 X 1.5 FLAT WASHER		01
05	0503010179	5/16" ZN SPRING WASHER		01
06	0503010337	5/16" NUT		01

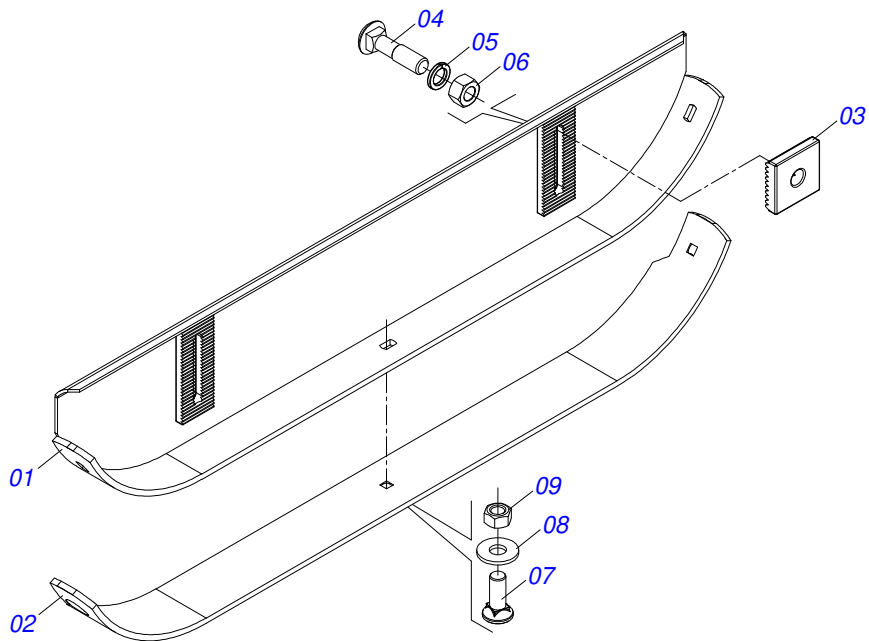

Item	Code	Description	See page	QT
01	0511064762	50"SKATE		02
02	0531019433	SKID GUIDE		02
03	0502010083	SQUARE WASHER		04
04	0501014177	5/8" X 2-1/2" BOLT		04
05	0503010027	5/8" SPRING WASHER		04
06	0503010013	5/8" NUT		04
07	0503012956	1/2" X 1-1/2" BOLT		06
08	0511017302	FLAT WASHER		06
09	0503012682	1/2" BSW NUT		06

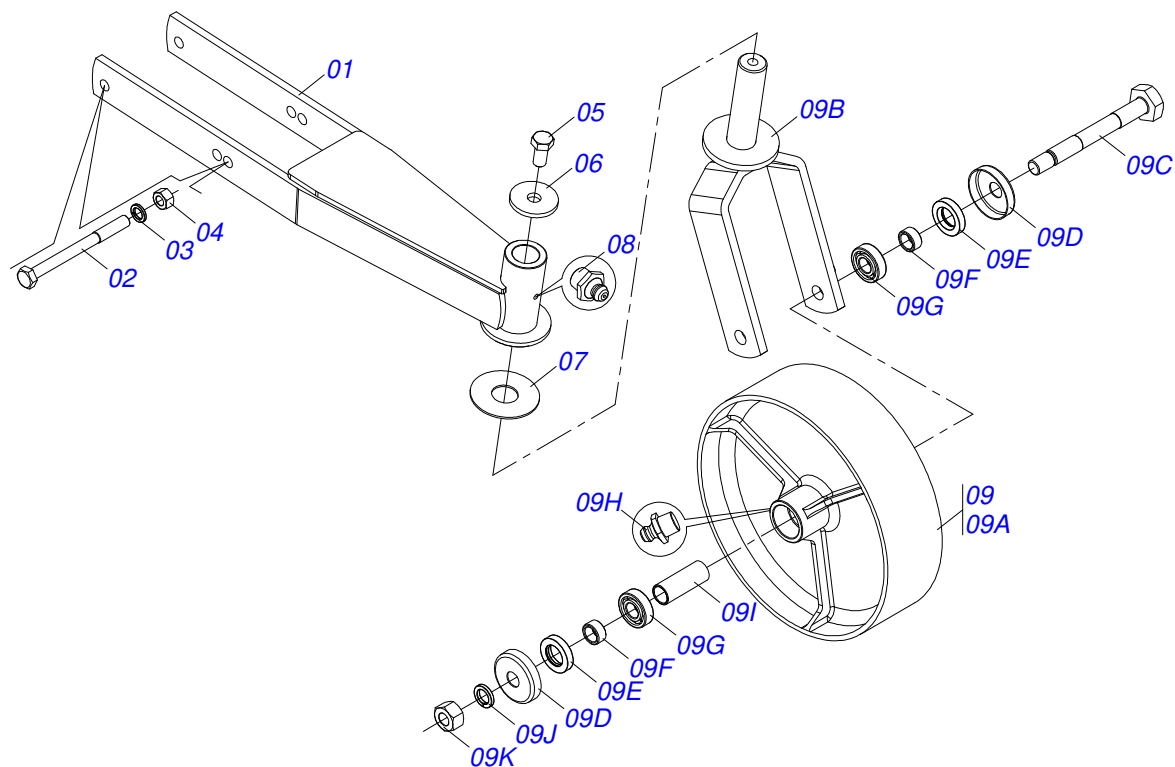

Item	Code	Description	See page	QT
01	0521065281	WHEEL SUPPORT		01
02	0503010795	5/8" X 7" BOLT		02
03	0503010027	5/8" SPRING WASHER		02
04	0503010013	5/8" NUT		02
05	0503010962	5/8" X 1-1/4" BOLT		01
06	0511010721	FLAT WASHER		01
07	0511013239	FLAT WASHER		01
08	0503010002	1800 GREASE FITTING		01
09	0501058460	CARRYING WHEELS		01
09A	0502012519	350 X 100 WHEEL		01
09B	0501065266	WHELL FORK		01
09C	0501017143	WHEEL AXLE		01
09D	0511014254	DUST CLOAK		02
09E	0503010268	00262-B SEAL		02
09F	0521010487	SPACER WASHER		02
09G	0503010269	6204 BALL BEARING		02
09H	0503010002	1800 GREASE FITTING		01
09I	0521010460	0.9" X 1.1" X 2.9" SLEEVE		01
09J	0503011442	3/4" SPRING WASHER		01
09K	0503010014	3/4" NUT		01

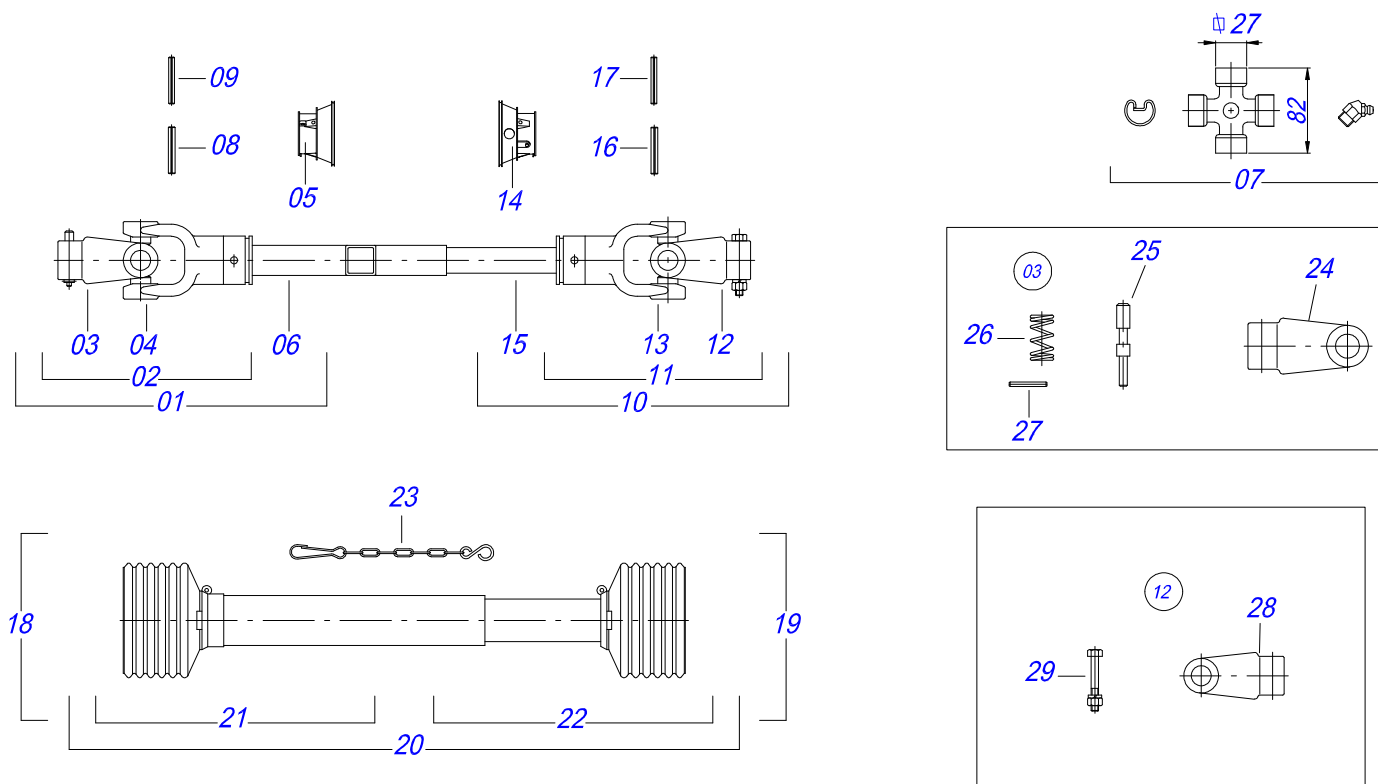

Item	Code	Description	See page	QT
01	0501050270	UNIVERSAL JOINT WITH SLEEVE		01
02	0501050265	UNIVERSAL JOINT		01
03	0501050333	1-40 TERMINAL WITH HITCH		01
04	0502010565	2-40 TERMINAL W/ SH 1.5"/1.5"		01
05	0503012069	ADAPTER FOR BUSHING PROTECT		01
06	0501017427	20" X 1.5" SQUARE SLEEVE		01
07	0503010836	CARDAN CROSSPIECE		02
08	0503011069	0.4" X 2.8" SPRING PIN		01
09	0503010510	0.2" X 2.6" SPRING PIN		01
10	0501050867	UNIVERSAL JOINT WITH SHAFT		01
11	0501050449	UNIVERSAL JOINT		01
12	0501052526	T8-40 TERMINAL WITH SCREW		01
13	0502010566	3-40 TERMINAL WITH SH 1.2"/1.2"		01
14	0503012070	ADAPTER FOR AXLE PROTECTION		01
15	0501017423	1.2" X 19.6" SQUARE SHAFT		01
16	0503010361	SPRING PIN		01
17	0503010756	0.2" X 2.4" SPRING PIN		01
18	0501051694	UNIVERSAL JOINT WITH SLEEVE/PROTECTION		01
19	0501051695	UNIVERSAL JOINT WITH AXLE/PROTECTION		01
20	0503012066	PROTECTION ASSY		01
21	0503012067	PROTECTION FOR UNIV JOINT AND SLEEVE		01
22	0503012068	PLASTIC PROTECTION FOR SHAFT JOINT		01
23	0503012023	CHAIN FOR PROTECTION		02
24	0502010563	1-40 STRIATED 1.3/8" TERMINAL		01
25	0521010638	0.5" X 3.3" QUIC HITCH COUPL SHAFT		01
26	0503030518	0.5"X1.0"X 0.1" COMPRESSION SPRING		01
27	0503010838	0.1" X 0.8" SPRING PIN		01
28	0502010876	8-40 STRIATED 1.3/8 TERMINAL		01
29	0501047756	1/2" X 3" SET PARTS		01

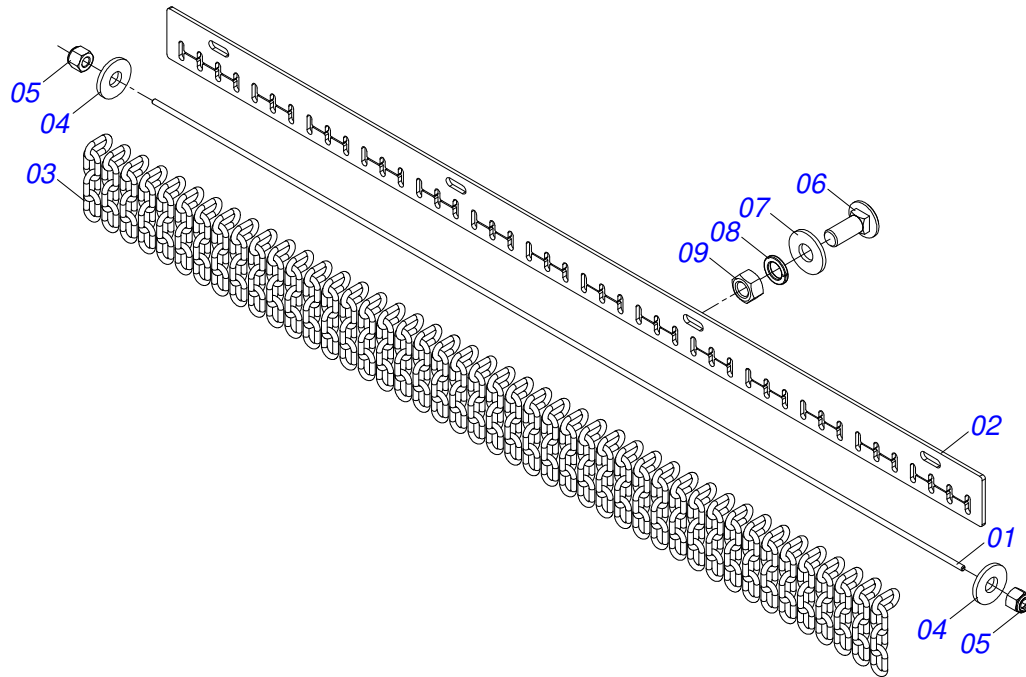

Item	Code	Description	See page	QT
01	0581013929	CURRENT PROTECTION ROD (1805)		01
02	0581013928	BODY FRONT CURRENT PROTECTION (1805)		01
03	0511011774	8,00 CHAIN 4 LINK		50
04	0501010984	FLAT WASHER		02
05	0503013759	NUT		02
06	0501011600	1/2" X 1-1/4" BOLT		04
07	0511017302	FLAT WASHER		04
08	0503010019	1/2" SPRING WASHER		04
09	0503012682	1/2" BSW NUT		04

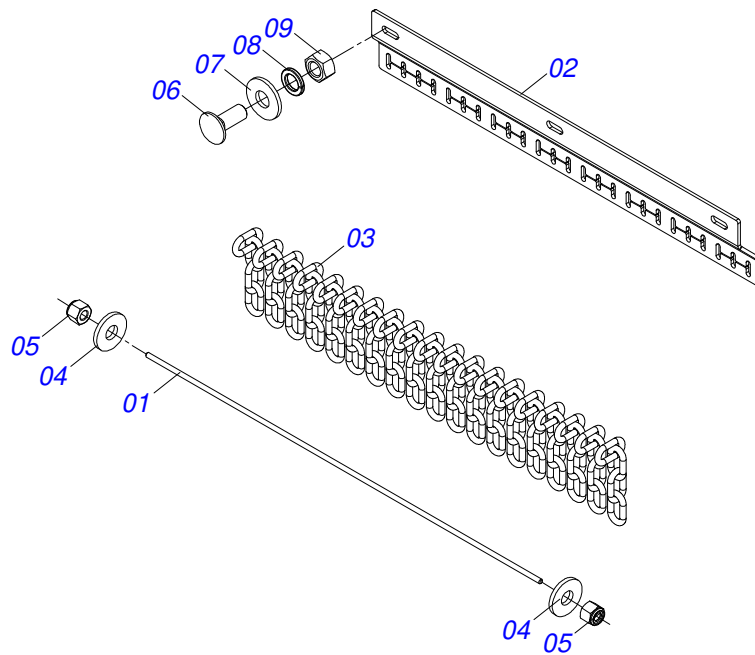

Item	Code	Description	See page	QT
01	0581013927	ROD CURRENT PROTECTION (910)		01
02	0581013926	BODY REAR CURRENT PROTECTION (910)		01
03	0511011774	8,00 CHAIN 4 LINK		25
04	0501010984	FLAT WASHER		02
05	0503013759	NUT		02
06	0501011600	1/2" X 1-1/4" BOLT		03
07	0511017302	FLAT WASHER		03
08	0503010019	1/2" SPRING WASHER		03
09	0503012682	1/2" BSW NUT		03

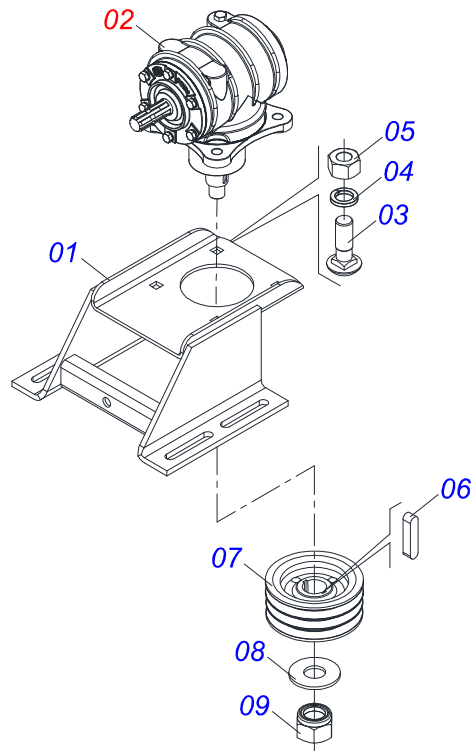

Item	Code	Description	See page	QT
01	0501067539	MULTIPLIER SUPPORT		01
02	0501046851	MULTIPLIER	14	01
03	0501017305	3/4" X 2-1/4" BOLT		04
04	0503011442	3/4" SPRING WASHER		04
05	0503010014	3/4" NUT		04
06	0501010536	KEYWAY SQUARE		02
07	0502011377	REEL 190 X 50 PULLEY		01
08	0561015762	FLAT WASHER		01
09	0503010817	1.1/4" SELF LOCKING NUT		01

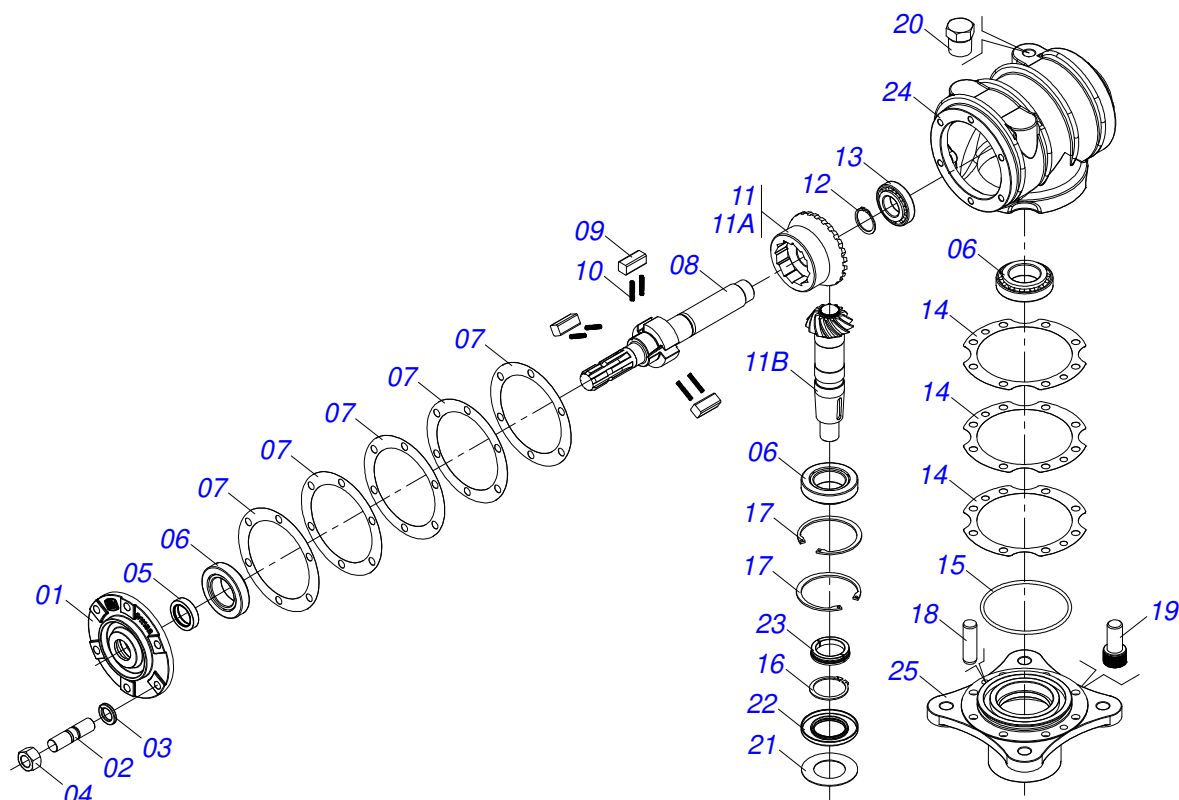

Item	Code	Description	See page	QT
01	0502011152	SMALLER COVER		01
02	0503030084	1/2" X 1/2" X 2.0" STUD		06
03	0503011440	SPRING WASHER		06
04	0503010028	1/2" NUT		06
05	0503011171	00912-BRG SEAL		01
06	0503010006	32210 ROLLER BEARING		03
07	0503030783	7.1" X 5.3" X 0.008" JOINT		05
08	0503050063	UPPER AXLE		01
09	0501010649	RATCHET CLICK		03
10	0503030051	0.2" X 1" X 0.1" COMPRESSION SPRING		06
11	0503060210	CROWN PINION SET		01
11A	0503050074	25Z CONICAL GEAR		01
11B	0503061048	PINION		01
12	0503010217	501040 CLAMPING RING (FOR AXLE)		01
13	0503010037	30207 ROLLER BEARING		01
14	0503030785	7.9" X 5.9" X 0.008" JOINT		03
15	0503010286	2-355 N 3006-9B O-RING		01
16	0503010396	501060 CLAMPING RING (FOR AXLE)		01
17	0503011190	SEAL RING		02
18	0503017877	PIN GUIDE		02
19	0503010562	1/2" X 1" BOLT		08
20	0503031604	1/2" BSP PLUG		01
21	0521018064	FLAT WASHER		01
22	0503011047	5089 SEAL		01
23	0511010142	LOCK RING		01
24	0502010984	LEFT MULTIPLIER BOX		01
25	0502011393	LOWER HUB		01

ANNOTATION



A series of horizontal lines for writing, consisting of 25 evenly spaced lines across the page.

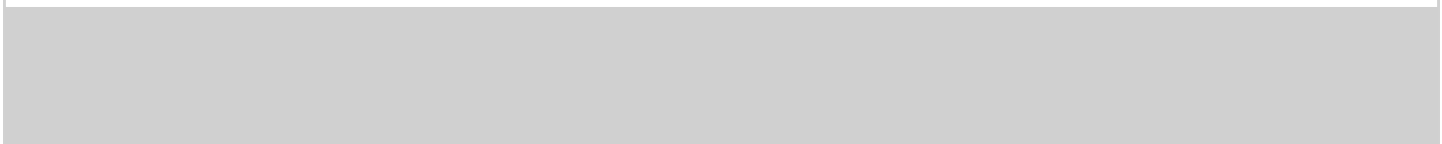



MARCHESAN

Technical Publications | Elaboration and Revision

LORENA ROCHA ALVES

www.marchesan.com.br

