

ROTARY CUTTERS

RC2 1700 WITH WHEEL/WITH CURRENT PROTECTION

Code: 0501093041
Series: S-1195
Revision: 00
Date Revision: AGOSTO/2021

PARTS CATALOGUE



MARCHESAN



PRODUCTS

Code	Description
0104100028	RC2 1700 C/R C/PROT CORR S-1195

ATTENTION: IMPORTANT

Marchesan S.A. reserves the right to improve and / or modify the technical features of its products, without obligation to do the same with those products already sold and without prior knowledge of the dealer or the consumer.



INDEX

0909095943	ASSY FRAME	1
0501050672	SEMIFINISHED FRAME	2
0501056337	SUPPORT	3
0501046851	MULTIPLIER	4
0909094987	SKID ASSY	5
0909095944	HEAD ASSY	6
0501047949	DRIVE SHAFT	7
0501054231	SET PROTECTION	8
0511047301	CARRYING WHEELS ASSY	9

ASSY FRAME

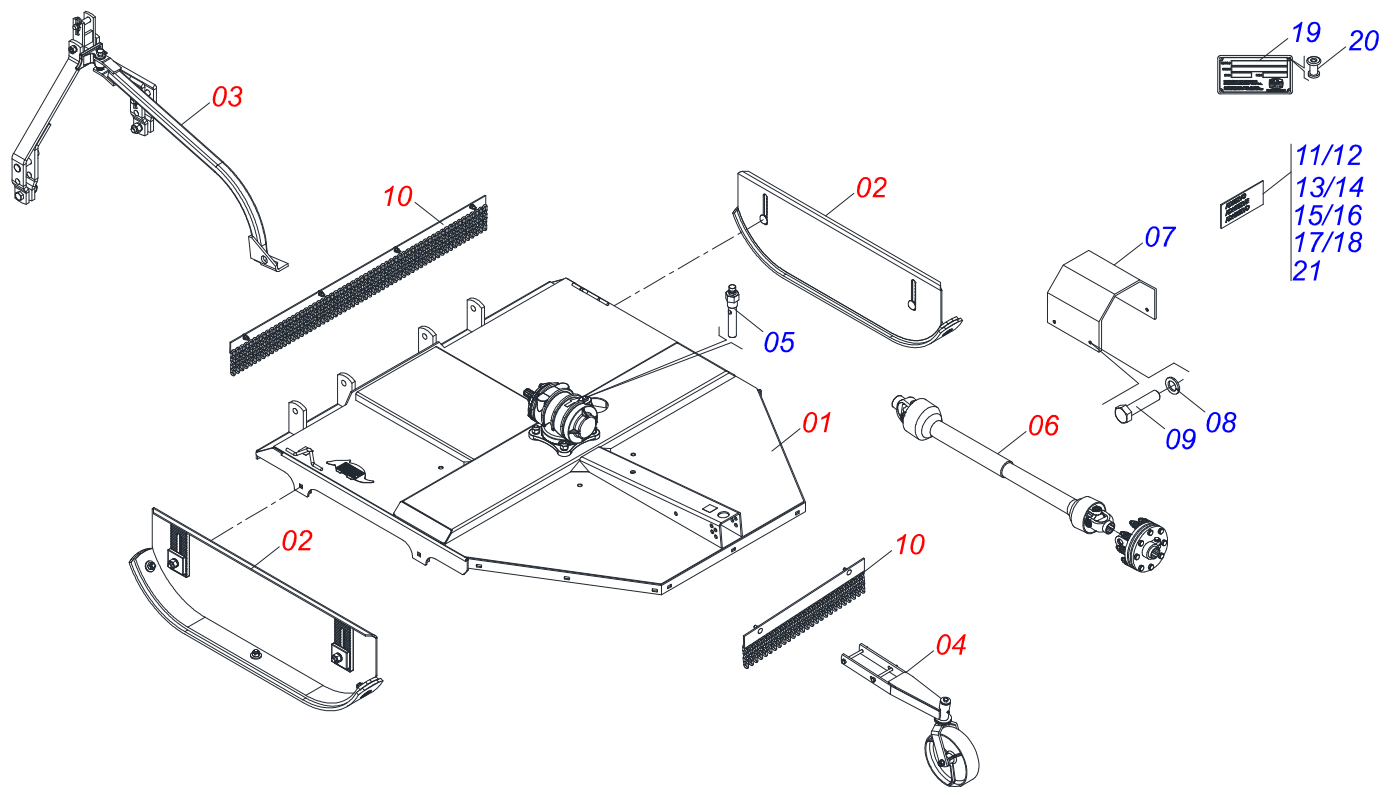

Item	Code	Description	See page	QT
01	0501050672	SEMIFINISHED FRAME	2	01
02	0909094987	SKID ASSY	5	01
03	0909095944	HEAD ASSY	6	01
04	0511047301	CARRYING WHEELS ASSY	9	01
05	0501110186	OIL SMALLER LEVEL INDICATOR		01
06	0501047949	DRIVE SHAFT	7	01
07	0531017832	PROTECTION COVER		01
08	0503010025	3/8" SPRING WASHER		04
09	0503010256	3/8" X 3/4" BOLT		04
10	0501054231	SET PROTECTION	8	01
11	0503031930	ADHESIVE LABEL		02
12	0503031428	READ MANUAL DECAL		01
13	0503031427	ADHESIVE LABEL		01
14	0503031929	ADHESIVE LABEL		01
15	0503031931	ADHESIVE LABEL		01
16	0503031087	ADHESIVE LABEL		01
17	0503031127	ADHESIVE LABEL		01
18	0503060889	SET LABEL ADHESIVE		01
19	0503034003	SERIAL NUMBER TAG 61 X 118		01
20	0503010001	3.2 X 5.5 RIVET		04
21	0503032949	ADHESIVE LABEL		01

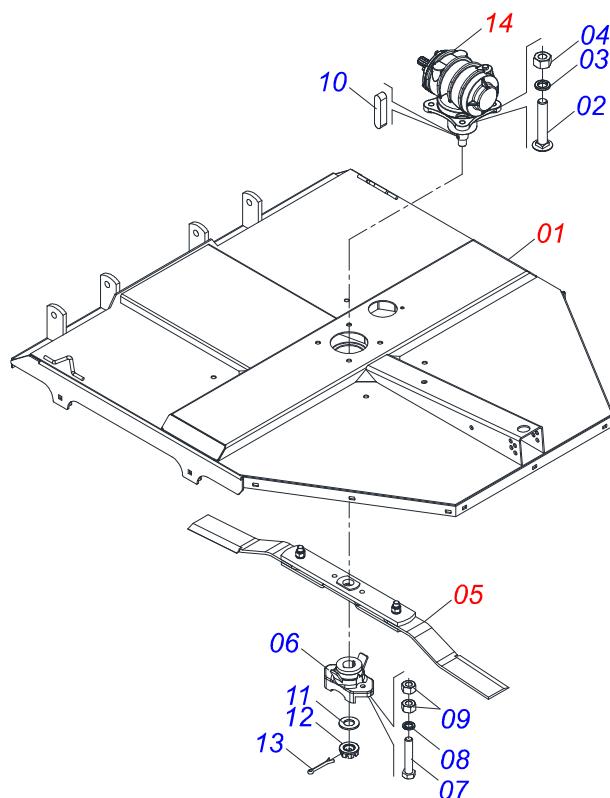

Item	Code	Description	See page	QT
01	0501067755	FRAME		01
02	0503013122	3/4 UNC X 4.1/4 CAPQ G.5 ZNBOLT		04
03	0503011442	3/4" SPRING WASHER		04
04	0503010014	3/4" NUT		04
05	0501056337	SUPPORT	3	01
06	0502012453	SUPPORT FLANGE		01
07	0503010901	3/4UNC 3.1/2 BOLT		02
08	0503011442	3/4" SPRING WASHER		02
09	0503010014	3/4" NUT		04
10	0501010536	KEYWAY SQUARE		02
11	0501017779	32 X 60 X 4.75 FLAT WASHER		01
12	0503011052	1.1/4" X 0.77" CASTLE NUT		01
13	0503010131	3/16" X 1-1/2" COTTERPIN		01
14	0501046851	MULTIPLIER	4	01

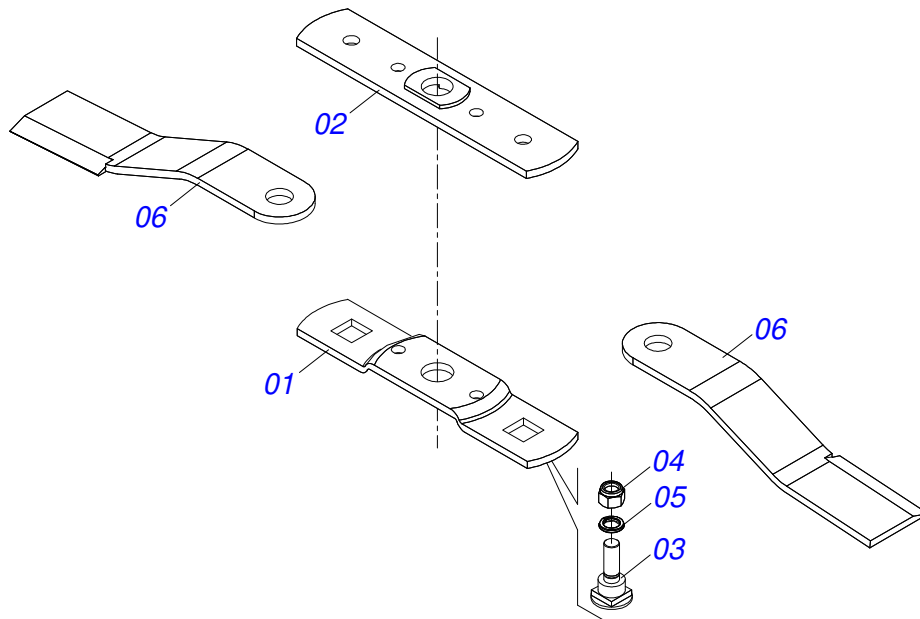

Item	Code	Description	See page	QT
01	0561017369	ROTARY LOWER SUPPORT LOWER		01
02	0561017307	SUPPORT UPPER BASE		01
03	0511019000	BOLT		02
04	0503010812	7/8" UNF SELF LOCKING NUT		02
05	0503011447	SPRING WASHER		02
06	0622400054	24.5" X 3.94" X 0.5" ROTARY CUTTER		02

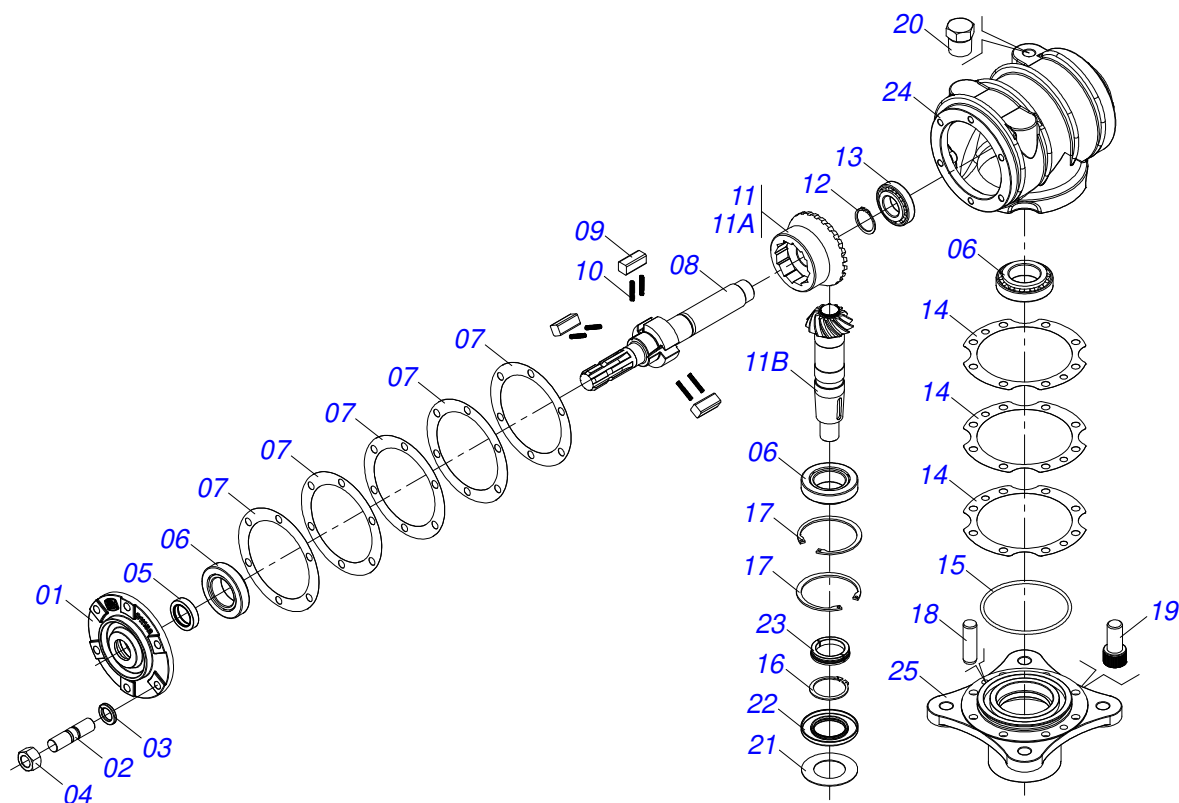

Item	Code	Description	See page	QT
01	0502011152	SMALLER COVER		01
02	0503030084	1/2" X 1/2" X 2.0" STUD		06
03	0503011440	SPRING WASHER		06
04	0503010028	1/2" NUT		06
05	0503011171	00912-BRG SEAL		01
06	0503010006	32210 ROLLER BEARING		03
07	0503030783	7.1" X 5.3" X 0.008" JOINT		05
08	0503050063	UPPER AXLE		01
09	0501010649	RATCHET CLICK		03
10	0503030051	0.2" X 1" X 0.1" COMPRESSION SPRING		06
11	0503060210	CROWN PINION SET		01
11A	0503050074	25Z CONICAL GEAR		01
11B	0503061048	PINION		01
12	0503010217	501040 CLAMPING RING (FOR AXLE)		01
13	0503010037	30207 ROLLER BEARING		01
14	0503030785	7.9" X 5.9" X 0.008" JOINT		03
15	0503010286	2-355 N 3006-9B O'RING		01
16	0503010396	501060 CLAMPING RING (FOR AXLE)		01
17	0503011190	SEAL RING		02
18	0503017877	PIN GUIDE		02
19	0503010562	1/2" X 1" BOLT		08
20	0503031604	1/2" BSP PLUG		01
21	0521018064	FLAT WASHER		01
22	0503011047	5089 SEAL		01
23	0511010142	LOCK RING		01
24	0502010984	LEFT MULTIPLIER BOX		01
25	0502011393	LOWER HUB		01

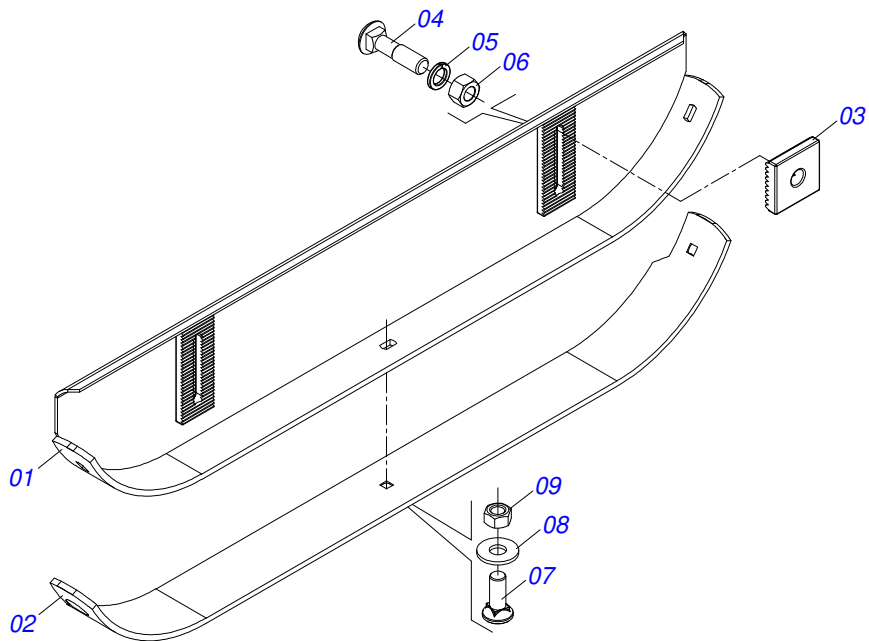

Item	Code	Description	See page	QT
01	0511064762	50"SKATE		02
02	0531019433	SKID GUIDE		02
03	0502010083	SQUARE WASHER		04
04	0501014177	5/8" X 2-1/2" BOLT		04
05	0503010027	5/8" SPRING WASHER		04
06	0503010013	5/8" NUT		04
07	0503012956	1/2" X 1-1/2" BOLT		06
08	0511017302	FLAT WASHER		06
09	0503012682	1/2" BSW NUT		06

HEAD ASSY

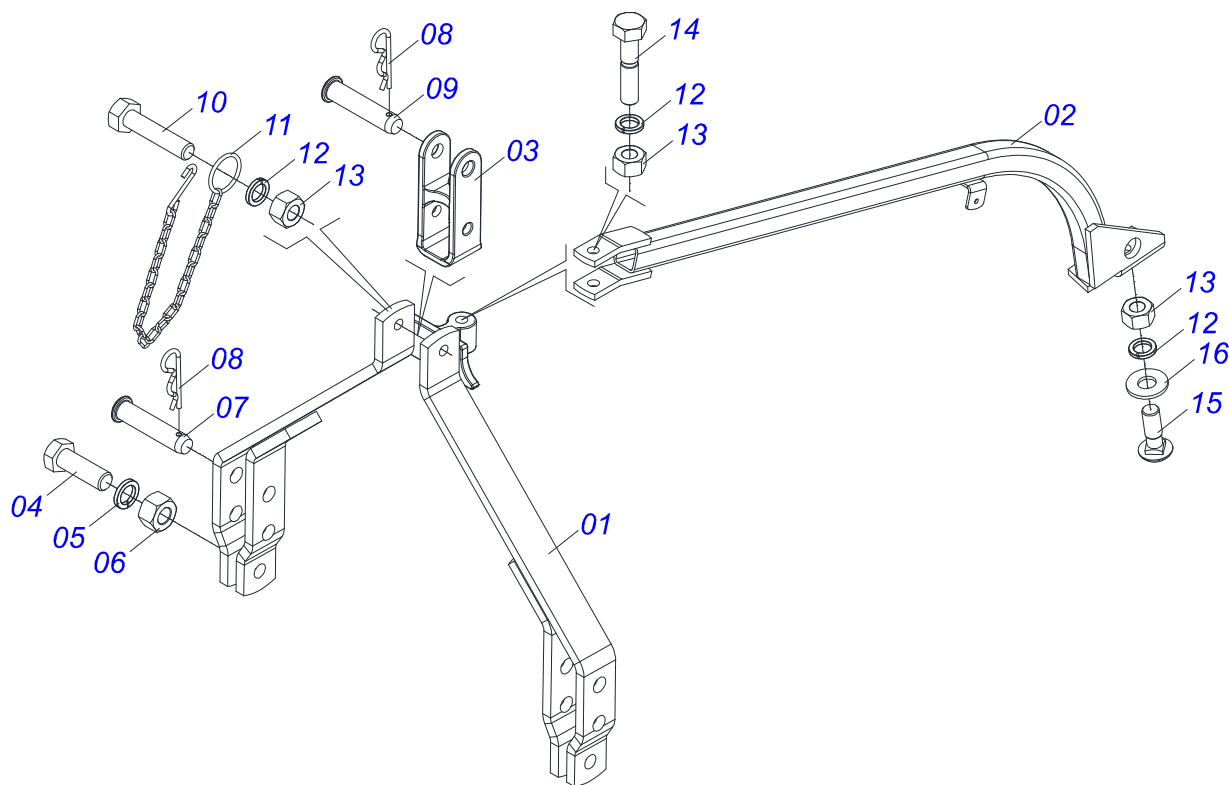

Item	Code	Description	See page	QT
01	0501067832	DRAWBAR	01	01
02	0521066524	ATTACHMENT BAR	01	01
03	1902040922	ROTARY COTTERS HEAD SUPPLEMENT	01	01
04	0503011432	BOLT	02	02
05	0503010012	1" SPRING WASHER	02	02
06	0501010059	1.5/8 NUT	02	02
07	0521010596	COUPLING SHAFT	02	02
08	0503031035	HAIR PIN	03	03
09	0521010578	COUPLING SHAFT	01	01
10	0503011198	C3/4" X 6" SCREW	01	01
11	0503011981	17.7" CHAIN WITH HOOK/LINK	02	02
12	0503010023	3/4" SPRING WASHER	03	03
13	0503010014	3/4" NUT	03	03
14	0501010216	3/4" X 4-1/2" BOLT	01	01
15	0501017305	3/4" X 2-1/4" BOLT	01	01
16	0501010322	FLAT WASHER	01	01

DRIVE SHAFT

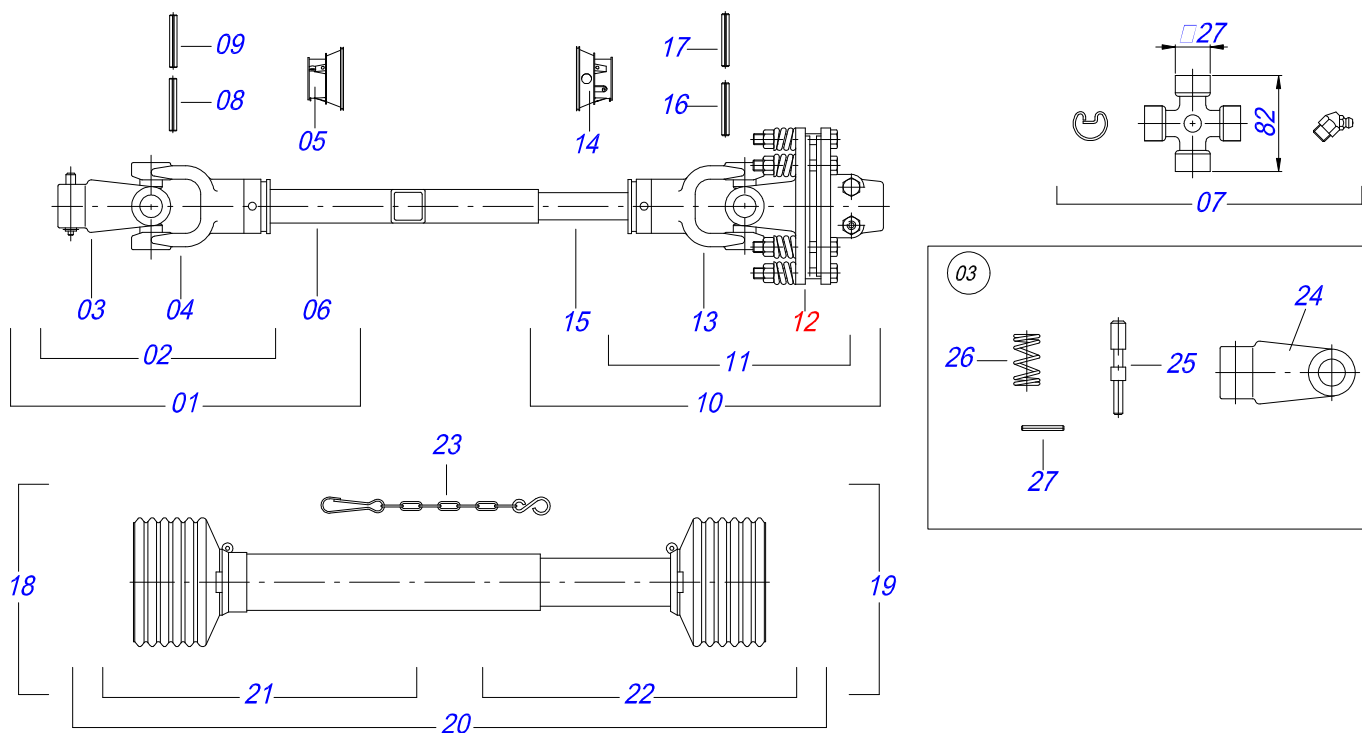

Item	Code	Description	See page	QT
01	0501051715	UNIVERSAL JOINT		01
02	0501050265	UNIVERSAL JOINT		01
03	0501050333	1-40 TERMINAL WITH HITCH		01
04	0502010565	2-40 TERMINAL W/ SH 1.5"/1.5"		01
05	0503012069	ADAPTER FOR BUSHING PROTECT		01
06	0501017429	31" X 1.5" SQUARE SLEEVE		01
07	0503010836	CARDAN CROSSPIECE		02
08	0503011069	0.4" X 2.8" SPRING PIN		01
09	0503010510	0.2" X 2.6" SPRING PIN		01
10	0501051716	UNIVERSAL JOINT WITH SHAFT		01
11	0501050466	UNIVERSAL JOINT WITH CROSSPIECE		01
12	0501043660	FRICTION		01
13	0502010566	3-40 TERMINAL WITH SH 1.2"/1.2"		01
14	0503012070	ADAPTER FOR AXLE PROTECTION		01
15	0501017425	1.2" X 31.5" SQUARE SHAFT		01
16	0503010361	SPRING PIN		01
17	0503010756	0.2" X 2.4" SPRING PIN		01
18	0501051701	UNIVERSAL JOINT WITH SLEEVE/PROT		01
19	0501051702	UNIVERSAL JOINT WITH AXLE/PROT		01
20	0503012077	PROTECTION ASSY		01
21	0503012078	PROTECTION FOR UNIV JOINT AND SLEEV		01
22	0503012079	PROTECTION FOR UNIV JOINT AND AXLE		01
23	0503012023	CHAIN FOR PROTECTION		02
24	0502010563	1-40 STRIATED 1.3/8" TERMINAL		01
25	0521010638	0.5" X 3.3" QUIC HITCH COUPL SHAFT		01
26	0503030518	0.5"X1.0"X 0.1" COMPRESSION SPRING		01
27	0503010838	0.1" X 0.8" SPRING PIN		01

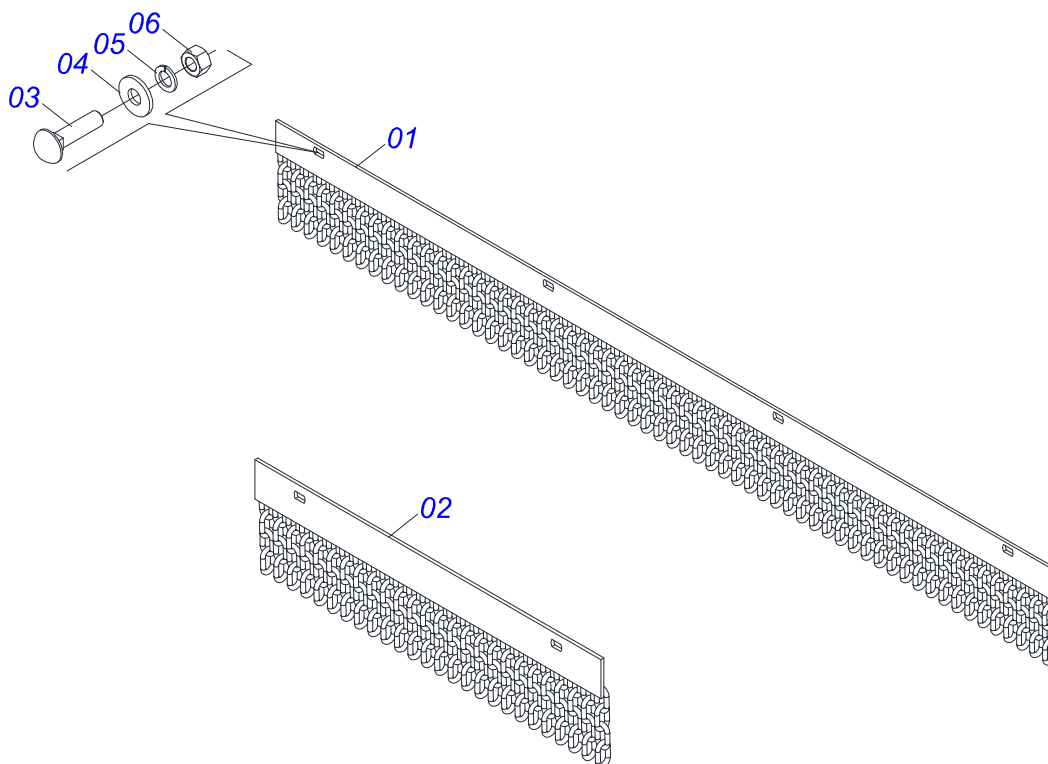

Item	Code	Description	See page	QT
01	0511063987	CURRENT PROTECTION FRONT		01
02	0511063984	PROTECTION		03
03	0501011600	1/2" X 1-1/4" BOLT		10
04	0511017302	FLAT WASHER		10
05	0503010019	1/2" SPRING WASHER		10
06	0503012682	1/2" BSW NUT		10

CARRYING WHEELS ASSY

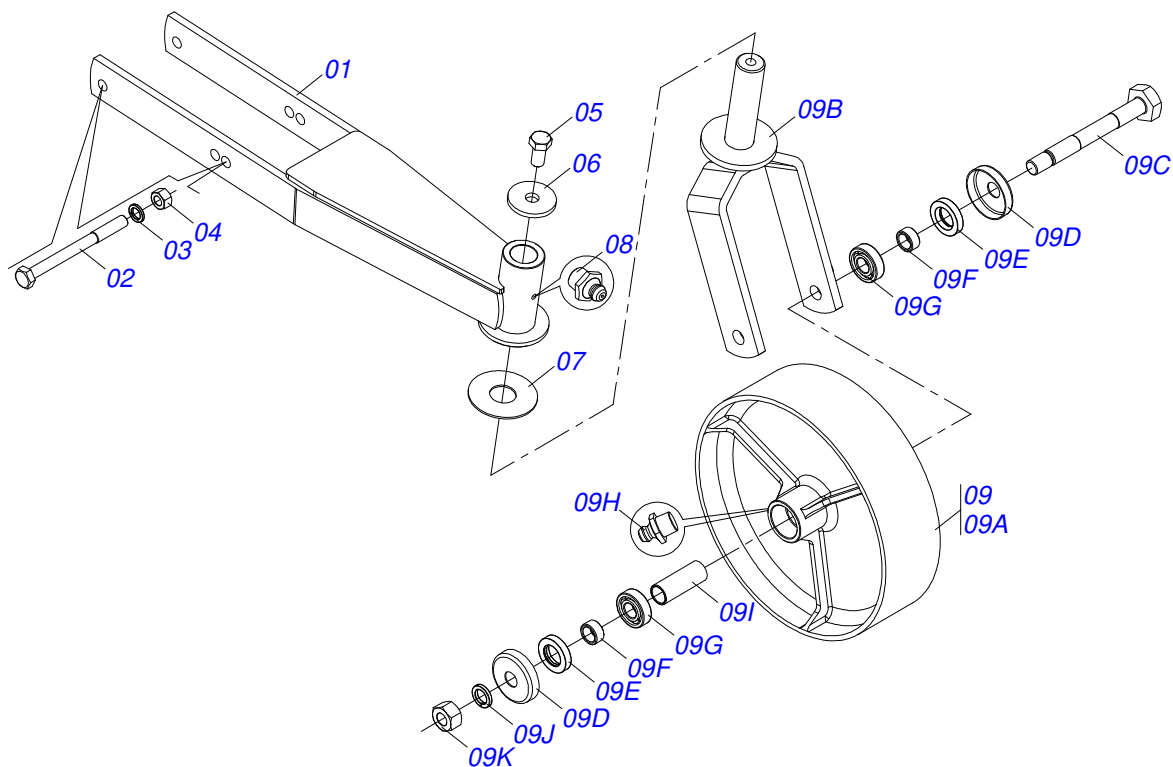

Item	Code	Description	See page	QT
01	0521065281	WHEEL SUPPORT		01
02	0503010795	5/8" X 7" BOLT		02
03	0503010027	5/8" SPRING WASHER		02
04	0503010013	5/8" NUT		02
05	0503010962	5/8" X 1-1/4" BOLT		01
06	0511010721	FLAT WASHER		01
07	0511013239	FLAT WASHER		01
08	0503010002	1800 GREASE FITTING		01
09	0501058460	CARRYING WHEELS		01
09A	0502012519	350 X 100 WHEEL		01
09B	0501065266	WHELL FORK		01
09C	0501017143	WHEEL AXLE		01
09D	0511014254	DUST CLOAK		02
09E	0503010268	00262-B SEAL		02
09F	0521010487	SPACER WASHER		02
09G	0503010269	6204 BALL BEARING		02
09H	0503010002	1800 GREASE FITTING		01
09I	0521010460	0.9" X 1.1" X 2.9" SLEEVE		01
09J	0503011442	3/4" SPRING WASHER		01
09K	0503010014	3/4" NUT		01



MARCHESAN

Technical Publications | Elaboration and Revision

LORENA ROCHA ALVES

www.marchesan.com.br

