

CHISEL PLOW

EST/MATIC 300 - 15 ROD

Code: 0501092653
Series: S-0413
Revision: 00
Date Revision: FEVEREIRO/2020

PARTS CATALOGUE



MARCHESAN



PRODUCTS

Code	Description
0101210004	EST/MATIC 300 15H DC RD SEM S-0413

ATTENTION: IMPORTANT

Marchesan S.A. reserves the right to improve and/or modify the technical features of its products, without obligation to do the same with those products already sold and without prior knowledge of the dealer or the consumer. The photos are only illustrative.



MARCHESAN

INDEX

0909098773	ASSY FRAME	1
0511053317	RIGHT WHEEL ASSY	2
0511053318	LEFT WHEEL ASSY	3
0521040391	HYDRAULIC CYLINDER 53,98 X 101,6 X 515 X 203	4
0521040915	HYDRAULIC CYLINDER 44,45 X 85,7 X 515 X 203	5
0501054088	DRAWBAR STABILIZER ASSEMBLY	6
0511048088	DRAWBAR JACK	7
0521041585	BREAK ROLLER 2250	8
0511051871	ARM BREAK ROLLER	9
0501042180	BEARING DUROMARK OL 192,5 X 1.1/4 IT	10
0521041963	ROD WITH ARM/DISARMENT	11
0521042014	BLADE DISC ASSY	12
0501052139	ASSY CUTTING DISK DPL18	13
0909098767	PLATFORM ASSEMBLY	14
0909098769	SUPPORT BOX SEED	15
0511054445	LEFT SUPPORT	16
0511054449	RIGHT SUPPORT	17
0501053421	VALVE MOTOR HYDRAULIC ASSY	18
0909098807	HYDRAULIC CIRCUIT	19
0909098806	HYDRAULIC CIRCUIT	20
0501053788	3/4 SQUARE AXLE FASTENER	21
0909098809	STICKER ASSY	22
0501053834	MALE QUICK COUPLER	23

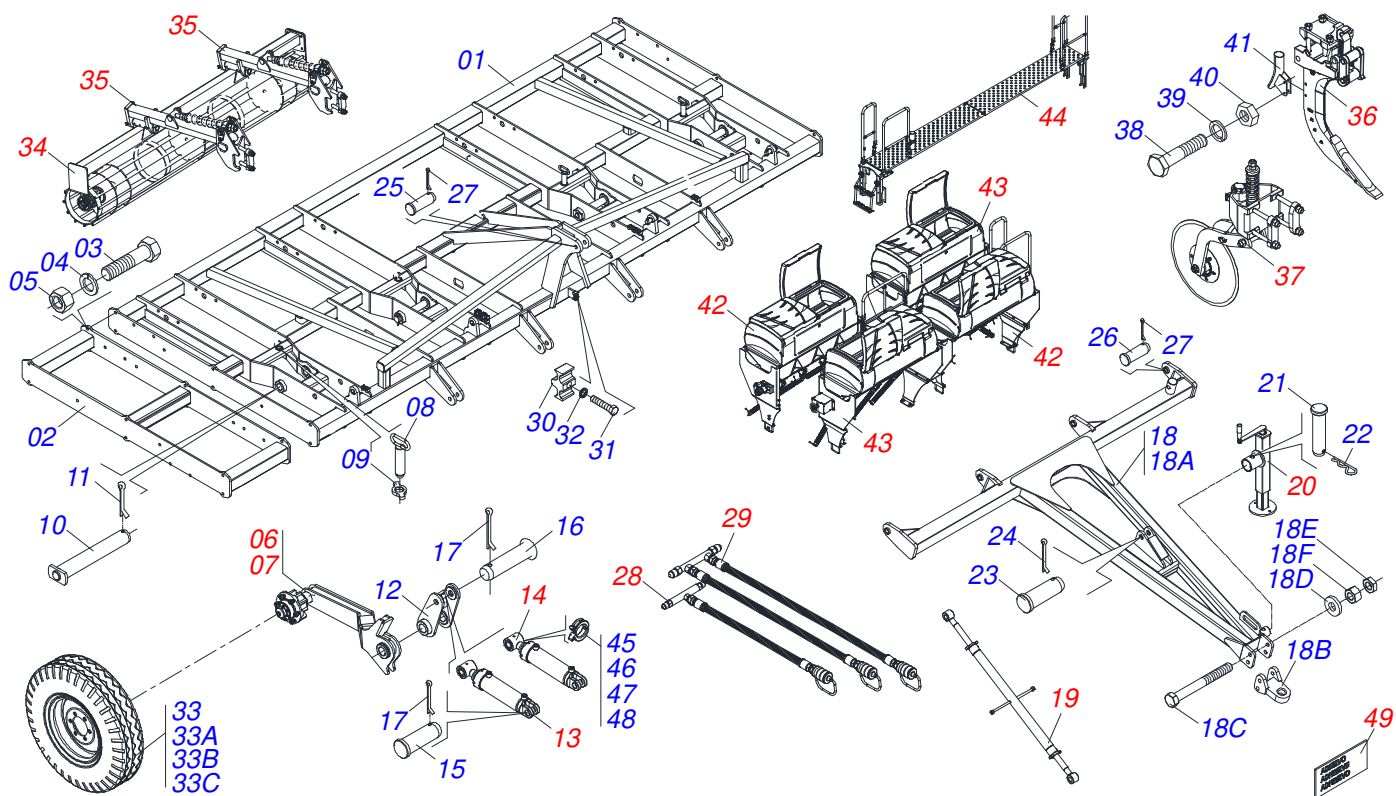

Item	Code	Description	See page	15 H
01	0521062470	FRAME 09-15 HASTES EST/MATIC 300		01
02	0521064120	EXTENSION		02
03	0501010125	3/4" X 2-1/2" BOLT		16
04	0503010023	3/4" SPRING WASHER		16
05	0503010014	3/4" NUT		16
06	0511053317	RIGHT WHEEL ASSY	2	01
07	0511053318	LEFT WHEEL ASSY	3	01
08	0521064086	ADJUSTMENT WHEEL		04
09	0541018672	COUNTERNUT		04
10	0521063252	50,85 X 332 AXLE		04
11	0503010073	3/8 X 3-1/2 COTTERPIN		04
12	0521064087	CARRYING-WHEELS PIVOT		04
13	0521040391	HYDRAULIC CYLINDER 53,98 X 101,6 X 515 X 203	4	02
14	0521040915	HYDRAULIC CYLINDER 44,45 X 85,7 X 515 X 203	5	02
15	0521012538	1.2" X 3.5" COUPLING SHAFT		04
16	0521010547	1.2" X 6.5" COUPLING SHAFT		04
17	0503010523	1/4" X 2" COTTERPIN		08
18	0521043174	DRAWBAR ASSY		01
18A	0521064359	DRAWBAR		01
18B	0511059885	TRACTOR HITCH ASSY		01
18C	0501010064	1" X 9" BOLT		02
18D	0521013252	FLAT WASHER		02
18E	0503013635	1" NUT		02
18F	0501010059	1.5/8 NUT		02
19	0501054088	DRAWBAR STABILIZER ASSEMBLY	6	01
20	0511048088	DRAWBAR JACK	7	01
21	0561014251	COUPLING SHAFT		01
22	0503031035	HITCH PIN CLIP		01
23	0521010780	1.2" X 4.5" COUPLING SHAFT		01
24	0503010571	1/4" X 1.1/2 COTTERPIN		02
25	0521012536	COUPLING SHAFT		01



ASSY FRAME

0909098773

Item	Code	Description	See page	15 H
26	0571012422	COUPLING SHAFT		04
27	0503010523	1/4" X 2" COTTERPIN		04
28	0909098807	HYDRAULIC CIRCUIT	19	01
29	0909098806	HYDRAULIC CIRCUIT	20	01
30	0502012702	BODY SUPPORT CLAMP		07
31	0503012555	SCREW 7/16 UNC X 2 CS RT G.7 ZN		07
32	0503010180	7/16" SPRING WASHER		07
33	0503062010	750 X 16-12L ASSY WHEEL AND TIRE		02
33A	0521062708	WHEEL 5,50 X 16 X 118 X 6F 16,50 X 152,40		02
33B	0503010033	7.50 X 16 INNER TIRE		02
33C	0503012864	TYRE		02
34	0521041585	BREAK ROLLER 2250	8	02
35	0511051871	ARM BREAK ROLLER	9	04
36	0521041963	ROD WITH ARM/DISARMMENT	11	15
37	0521042014	BLADE DISC ASSY	12	15
38	0501010096	3/8" X 2" BOLT		30
39	0503010025	3/8" SPRING WASHER		30
40	0503010026	3/8" NUT		30
41	0521064373	FINE SEED CONDUCTOR		15
42	0511054445	LEFT SUPPORT	16	02
43	0511054449	RIGHT SUPPORT	17	02
44	0909098767	PLATFORM ASSEMBLY	14	01
45	0501047895	ROD STOP		06
46	0501047885	ROD STOP		02
47	0501047886	ROD STOP		02
48	0501047887	ROD STOP		02
49	0909098809	STICKER ASSY	22	01

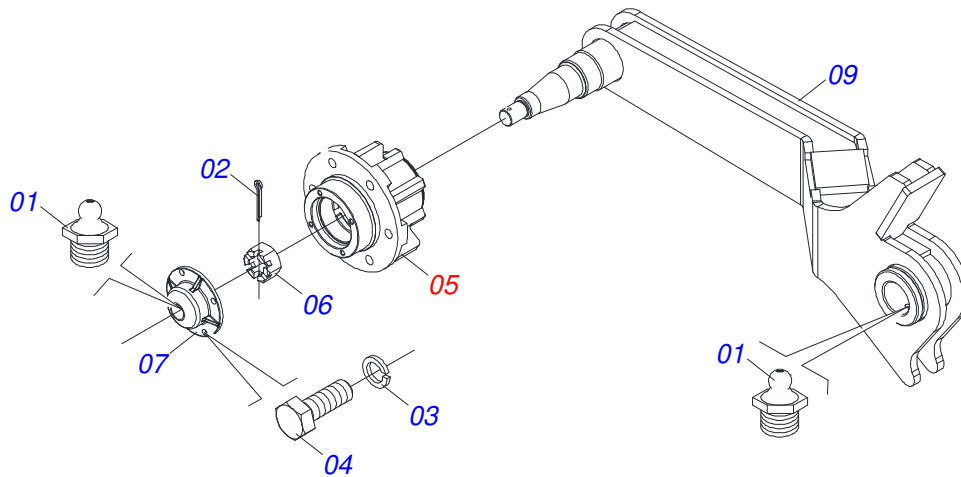

Item	Code	Description	See page	QT
001	0503010002	1800 GREASE FITTING		02
002	0503010018	5/32 X 1-1/2 COTTERPIN		01
003	0503011444	SPRING WASHER		04
004	0503010358	5/16" X 5/8" BOLT		04
005	0501051142	CARRYING WHEEL HUB		01
006	0503030009	1" CASTLE NUT		01
007	0502020591	PROTECCION COVER		01
008	0501016545	FLAT WASHER		01
009	0521064084	WHEELS RIGHT EST/MATIC 300		01

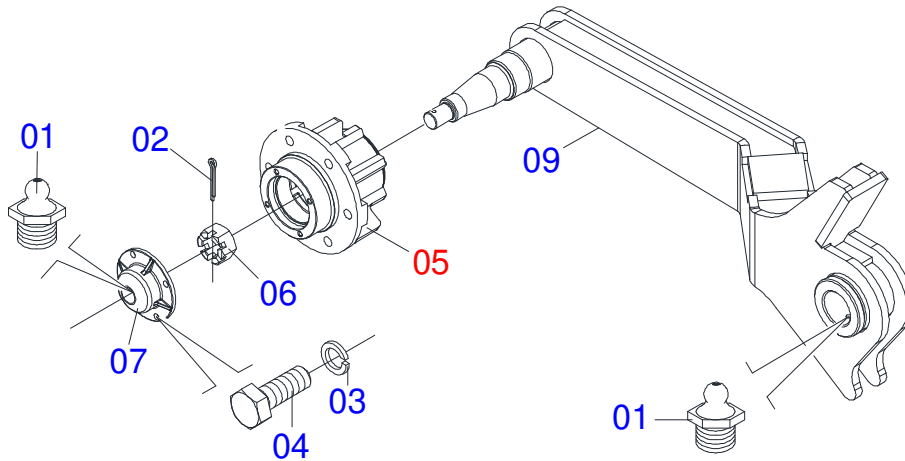

Item	Code	Description	See page	QT
001	0503010002	1800 GREASE FITTING		02
002	0503010018	5/32 X 1-1/2 COTTERPIN		01
003	0503011444	SPRING WASHER		04
004	0503010358	5/16" X 5/8" BOLT		04
005	0501051142	CARRYING WHEEL HUB		01
006	0503030009	1" CASTLE NUT		01
007	0502020591	PROTECCION COVER		01
008	0501016545	FLAT WASHER		01
009	0521064085	CARRYNG-WHEELS LEFT EST/MATIC 300		01

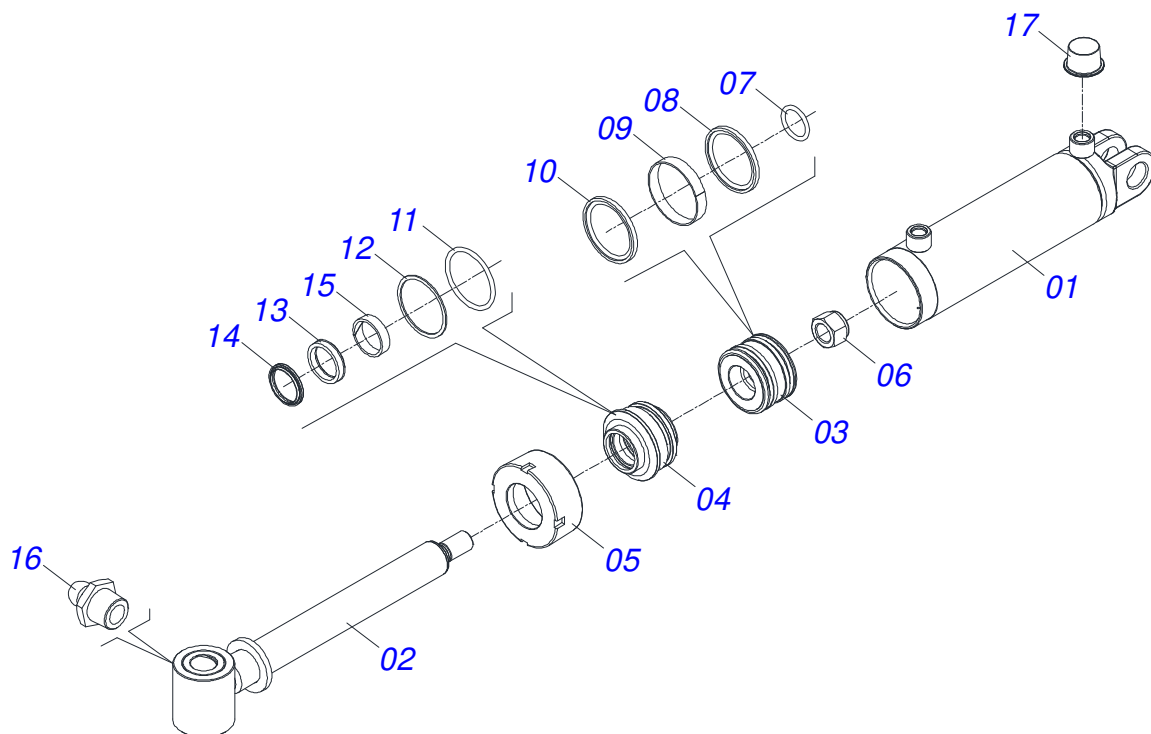

Item	Code	Description	See page	QT
01	0511068373	101,6 X 203 CYLINDER CASE		01
02	0521062882	53,98 X 448 TURNBUCKLE		01
03	0502011249	PISTON		01
04	0502011250	RING OF SUPPORT		01
05	0502010017	4" HEAD		01
06	0503010817	1.1/4" SELF LOCKING NUT		01
07	0503010345	2-218 N 3006-9B O'RING		01
08	0503012725	GASKET		01
09	0503010994	W2-4000-500 PK RING G.E		01
10	0503010043	PACKING 3750-3250		01
11	0503010338	2-342 N 3006-9B O'RING		01
12	0503011061	8-342 BACK-UP RING		01
13	0503010319	D-2125 SCRAPER		01
14	0503010314	GASKET		01
15	0503010973	W2-2500-500 PK O'RING G.E		01
16	0503010002	1800 GREASE FITTING		01
17	0503030384	CON PLUG N-001		02
18	0511031218	CYLINDER REPAIR KIT 53,98 X 101,6		01

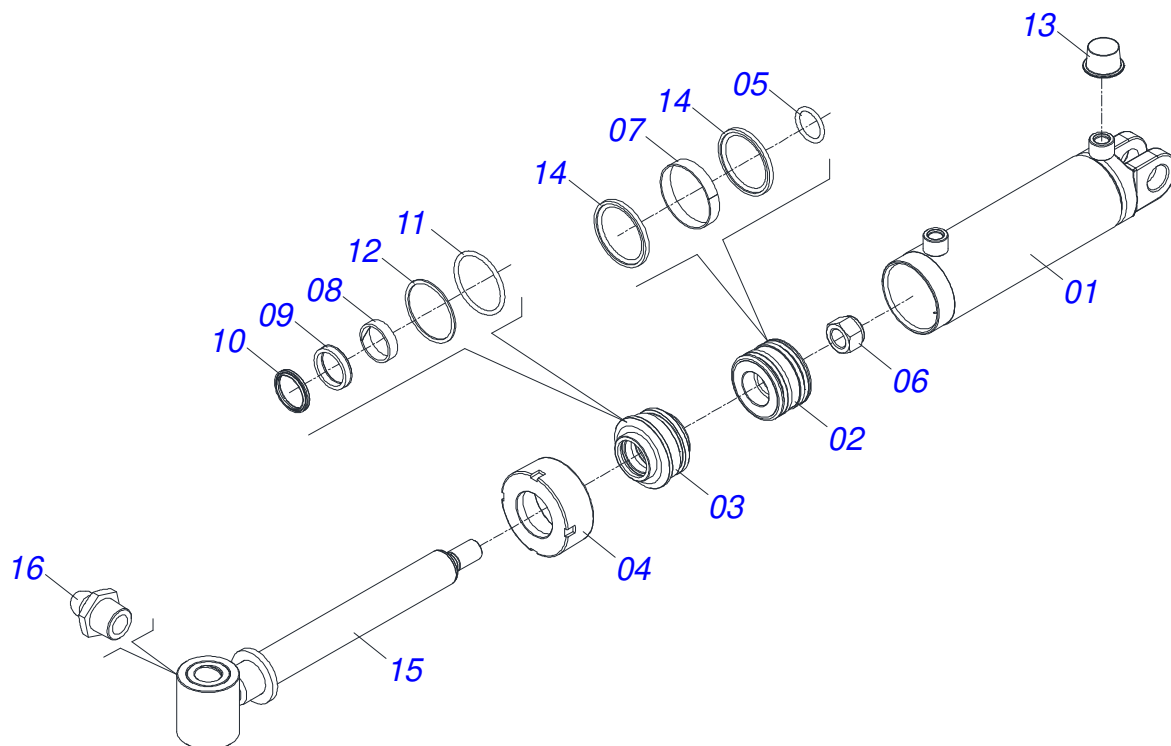

Item	Code	Description	See page	QT
01	0511068372	85,72 X 203 CYLINDER CASE		01
02	0502011847	1.7" X 3.4" PISTON		01
03	0502010781	RING SUPPORT		01
04	0502010993	DETACHABLE COVER		01
05	0503010042	2-214 N 3006-9B O'RING		01
06	0503010063	1" SELF-ALIGNING NUT		01
07	0503010948	W4-3346-590 PK RING G.E		01
08	0503010949	W2-2000-500 PK RING G.E		01
09	0503010990	GASKET		01
10	0503010761	D-1750 SCRAPER RING		01
11	0503010976	2-336 N 3006-9B O'RING		01
12	0503011060	8-336 BACK-UP RING		01
13	0503030384	CON PLUG N-001		02
14	0503012509	GASKET		02
15	0521063254	44,45 X 450 TURNBUCKLE		01
16	0503010002	1800 GREASE FITTING		01
17	0501035169	CYLINDER REPAIR KIT 44,45 X 85,72		01

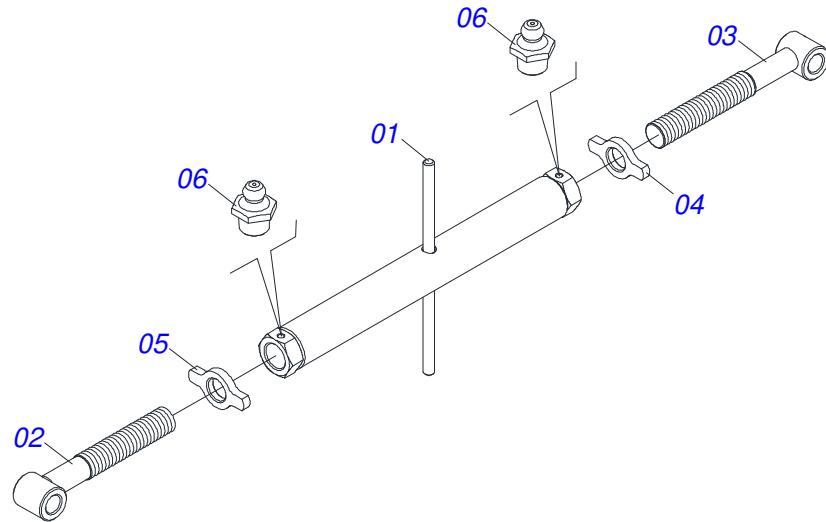

Item	Code	Description	See page	QT
01	0511063786	EXTENDER 950		01
02	0511063787	RIGHT EXTENDER SPINDLE R1.1/2 X 432		01
03	0511063788	LEFT EXTENDER SPINDLE R1.1/2 X 432		01
04	0541018672	COUNTERNUT		01
05	0541018673	COUNTERNUT		01
06	0503010002	1800 GREASE FITTING		02

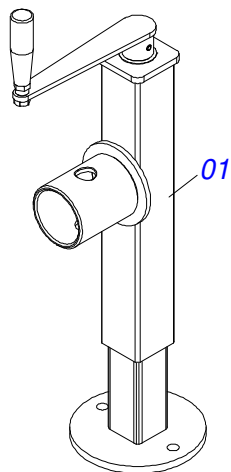

Item	Code	Description	See page	QT
01	0503062227	DRAWBAR JACK		01

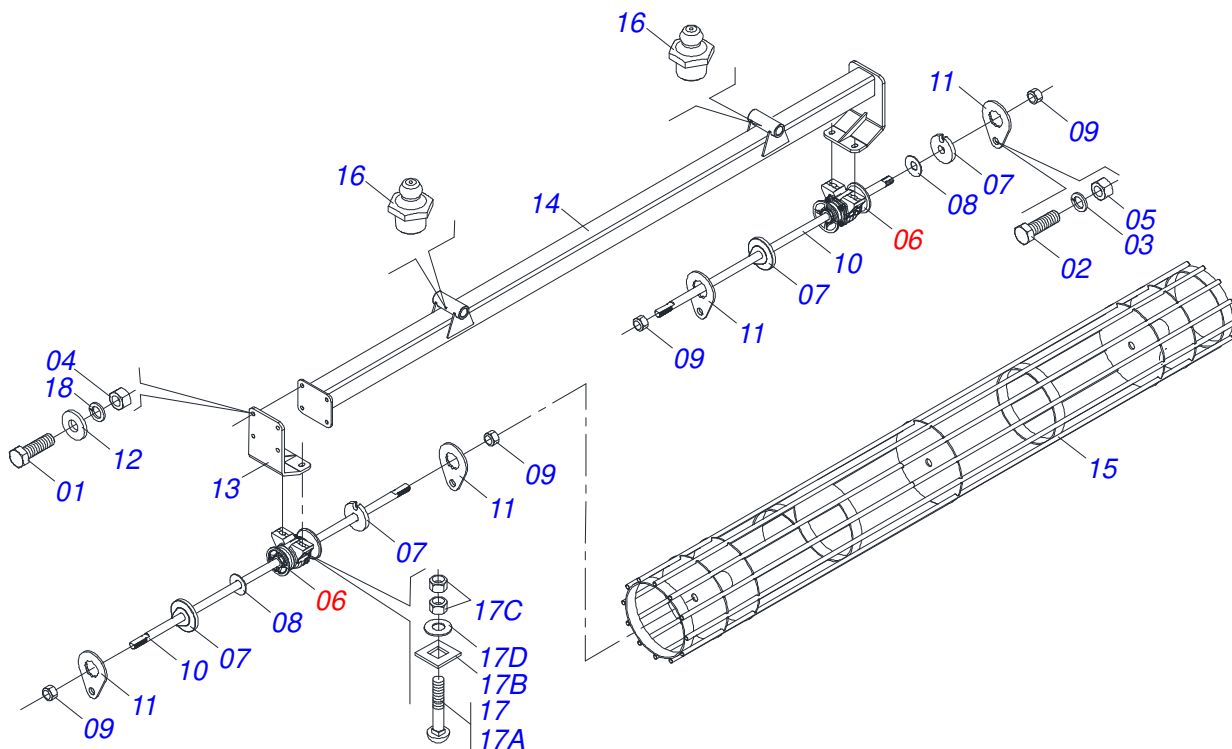

Item	Code	Description	See page	QT
001	0501010100	SCREW 5/8 UNC X 2 CS G.5 ZN		04
002	0501010161	1/2" X 1.1/4" BOLT		04
003	0503011440	SPRING WASHER		04
004	0503010013	5/8" NUT		04
005	0503010060	1/2" NUT		04
006	0501042180	BEARING DUROMARK OL 192,5 X 1.1/4 IT	10	02
007	1902010835	1-1/4" EXTERNAL AXLE WASHER		04
008	0531018575	WASHER CONCAVE		02
009	0501010087	1.1/4" NUT		04
010	0501010752	1.1/4" X 500 AXLE		02
011	0501010455	1.1/4" NUT LOCK		04
012	0501012140	FLAT WASHER		04
013	0521062673	BRACKET MOBILE FIXER ROLLER		01
014	0521063280	2250 BREAK ROLLER SUPPORT		01
015	0521063279	BREAK ROLLER 2250		01
016	0503010002	1800 GREASE FITTING		02
017	0501058802	5/8 UNC X 2.3/4 BOLT ASSY		04
017A	0503015154	5/8" X 2.3/4" BOLT		01
017B	0501010947	5/8 NUT LOCK		01
017C	0503010013	5/8" NUT		02
017D	0501012140	FLAT WASHER		01
018	0503010027	5/8" SPRING WASHER		04

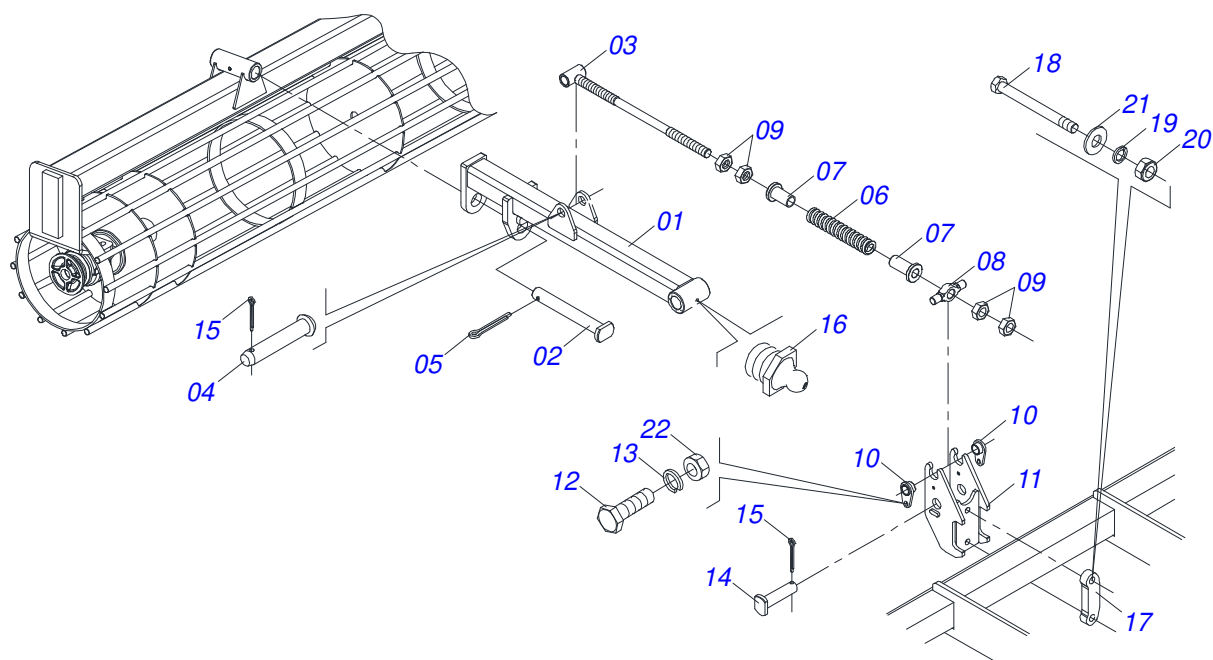

Item	Code	Description	See page	QT
00	0511051871	ARM BREAK ROLLER	9	01
01	0521063139	ARM ROLLER		01
02	0521010808	1.4" X 5.8" COUPLING SHAFT		01
03	0521063150	ASSY		01
04	0521010578	COUPLING SHAFT		01
05	0503010523	1/4" X 2" COTTERPIN		01
06	0503031575	2.5"X 12" X 0.5" COMPRESSION SPRING		01
07	0571011377	SPRING GUIDES SLEVE		02
08	0571011378	TRUNNION ARTICULATOR SPRING ROD		01
09	0501010059	1.5/8 NUT		04
10	0521063151	TRUNNION LOCK ARTICULATOR SPRING ROD		02
11	0521063134	FIXER ROLL		01
12	0503010920	1/2" X 1.1/2" BOLT		02
13	0503010019	1/2" SPRING WASHER		02
14	0521062685	ARTICULATION AXIS		01
15	0503012267	5/16" X 3" COTTER PIN		02
16	0503010002	1800 GREASE FITTING		01
17	0571011609	FIXER PLATE CUTTING DISC		01
18	0503014744	3/4 UNF X 7.1/2 C S G.7 ZN BOLT		02
19	0503010023	3/4" SPRING WASHER		02
20	0503010335	3/4"NUT		02
21	0511019685	FLAT WASHER		02
22	0503010060	1/2" NUT		02

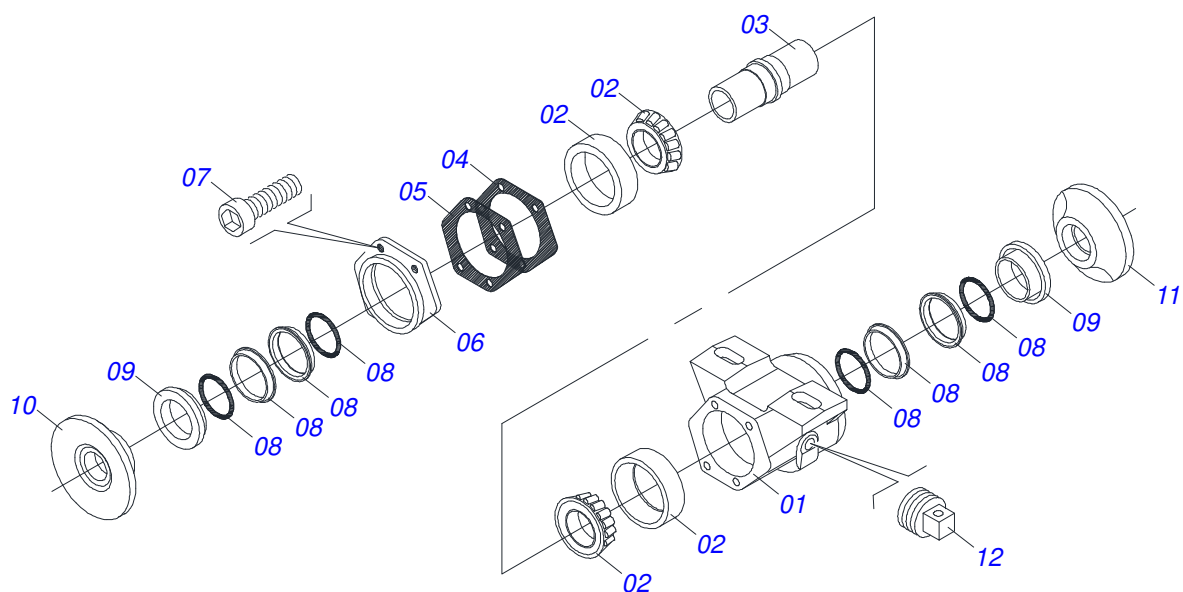

Item	Code	Description	See page	QT
01	0502010539	HOUSING DM		01
02	0503010111	30210 ROLLER BEARING		02
03	0502040218	AXLE		01
04	0503030013	4.4" X 3.5" X 0.004" JOINT		02
05	0503030684	4.4" X 3.5" X 0.004" JOINT		01
06	0502020424	HOUSING CAP		01
07	0503010134	3/8" X 1" BOLT		04
08	0503030026	SEAL LP JB-253		02
09	0502010541	SEAL RETAINER		02
10	0502010070	OUTER FLANGE		01
11	0502010071	INNER FLANGE		01
12	0503010856	OIL PLUG		01

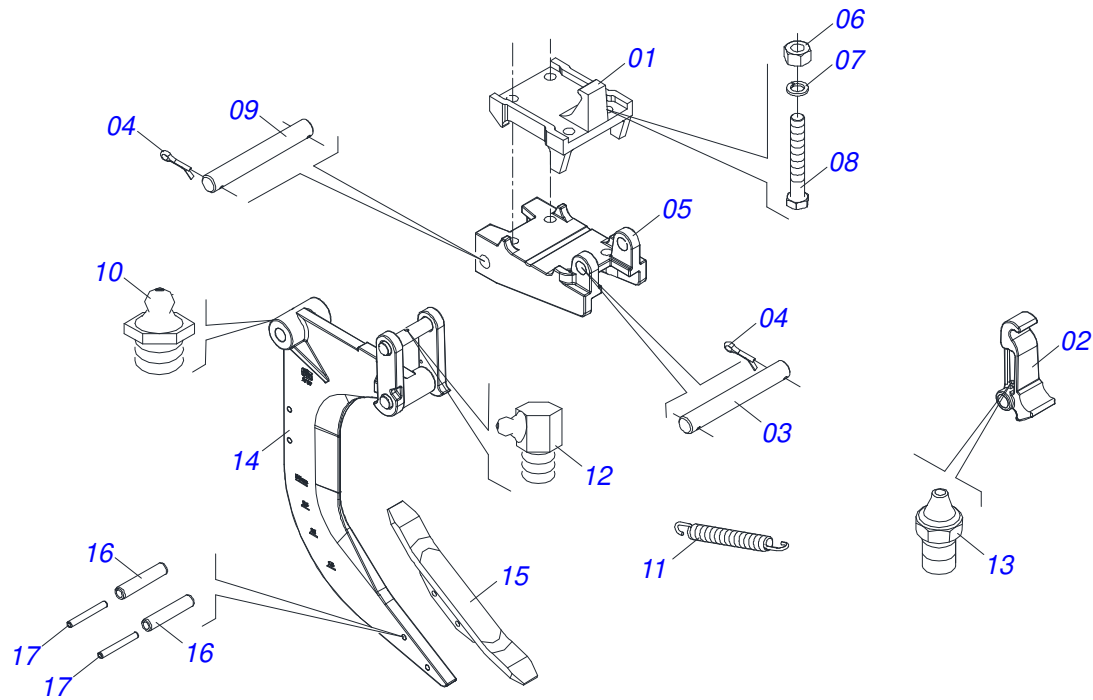

Item	Code	Description	See page	QT
001	0502011861	FIXER BASE UPPER		01
002	0502011864	AST/MATIC 450 RESET		01
003	0521017724	1" X 6.2" COUPLING SHAFT		01
004	0503010571	1/4" X 1.1/2" COTTERPIN		04
005	0502011863	LOWER BASE FIXER		01
006	0503010014	3/4" NUT		04
007	0503011442	3/4" SPRING WASHER		04
008	0503012729	3/4" X 6-3/4" BOLT		04
009	0521017725	1" X 7.4" COUPLING SHAFT		01
010	0503010002	1800 GREASE FITTING		01
011	0503031574	6.9" X 0.8" X 0.1" EXTENSION SPRING		01
012	0503010004	1890 GREASE FITTING		02
013	0503010691	1/4" GREASE FITTING		01
014	0521063902	ROD BODY DISASSEMBLE		01
015	0521063903	POINT 16 X 2 X 5/8		01
016	0503011265	10MM X 50MM SPRING PIN		02
017	0503010775	SPRING PIN		02

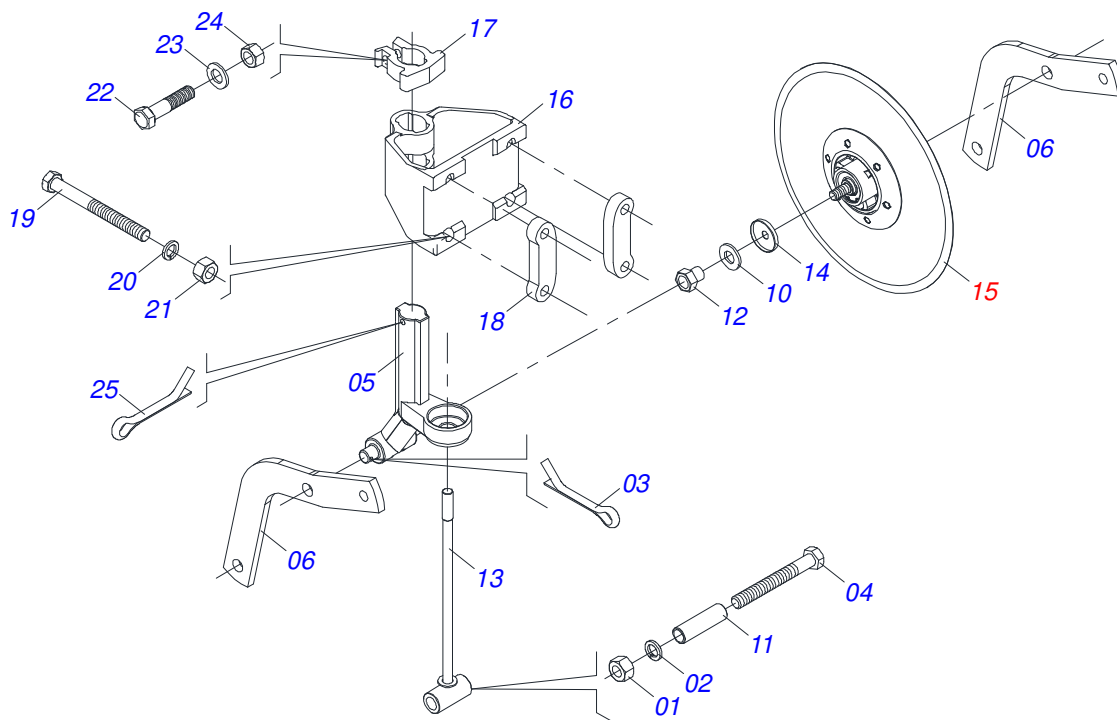

Item	Code	Description	See page	QT
01	0503010014	3/4" NUT		03
02	0503011442	3/4" SPRING WASHER		01
03	0503010571	1/4" X 1.1/2 COTTERPIN		02
04	0503011198	C3/4" X 6" SCREW		01
05	0502012025	BLADE DISC SUPPORT		01
06	0521019800	BLADE DISC BREAK		02
07	0511061576	SPRING GUIDE		01
08	0503031679	COMPRES SPRING		01
09	0502020393	SPRING UPPER SUPPORT		01
10	0511015346	FLAT WASHER		02
11	0521010452	SLEEVE		01
12	0521013510	3/4" NUT		02
13	0511060915	ROD SPRING		01
14	0521015376	DUST CLOAK		02
15	0501052139	ASSY CUTTING DISK DPL18	13	01
16	0502012026	BLADE DISC FIXER SUPPORT		01
17	0502012024	FIXER SUPPORT BUSHING		01
18	0571011609	FIXER PLATE CUTTING DISC		02
19	0503014744	3/4 UNF X 7.1/2 C S G.7 ZN BOLT		04
20	0503010023	3/4" SPRING WASHER		04
21	0503010335	3/4"NUT		04
22	0503013184	5/8" X 2-3/4" BOLT G.8		01
23	0501011299	FLAT WASHER		01
24	0503010129	5/8" NUT		01
25	0503010534	3/8 X 2-1/2 COTTERPIN		01

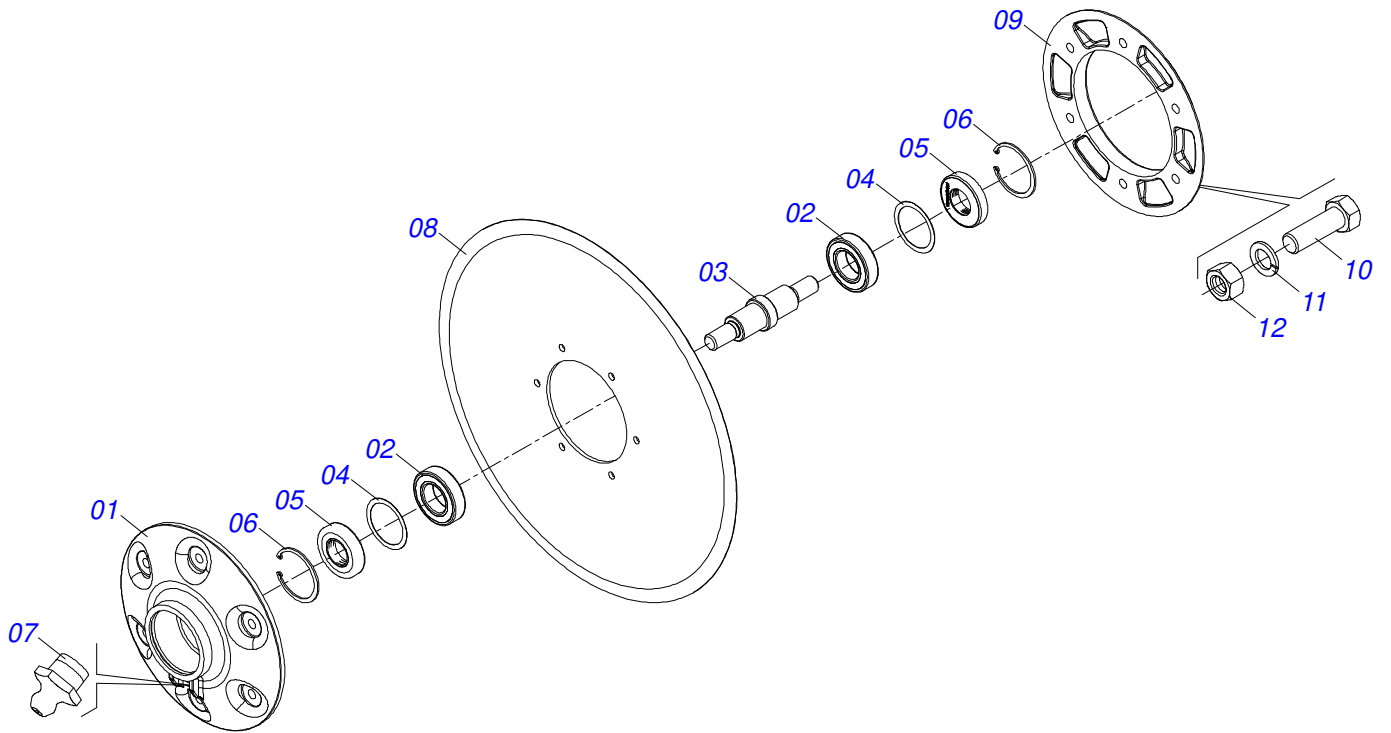

Item	Code	Description	See page	QT
01	0502011562	DISC HUB		01
02	0503010276	6206 BALL BEARING		02
03	0521013610	BLADE DISC HUB AXLE		01
04	0503030832	FLAT WASHER		02
05	0503012417	SEAL		02
06	0503011800	SEAL RING		02
07	0503010691	1/4" GREASE FITTING		01
08	0603026013	PLAIN COULTER BLADE		01
09	0502020641	BLADE DISC FLANGE		01
10	0503010371	5/16" X 1" BOLT		06
11	0503011444	SPRING WASHER		06
12	0503010337	5/16" NUT		06

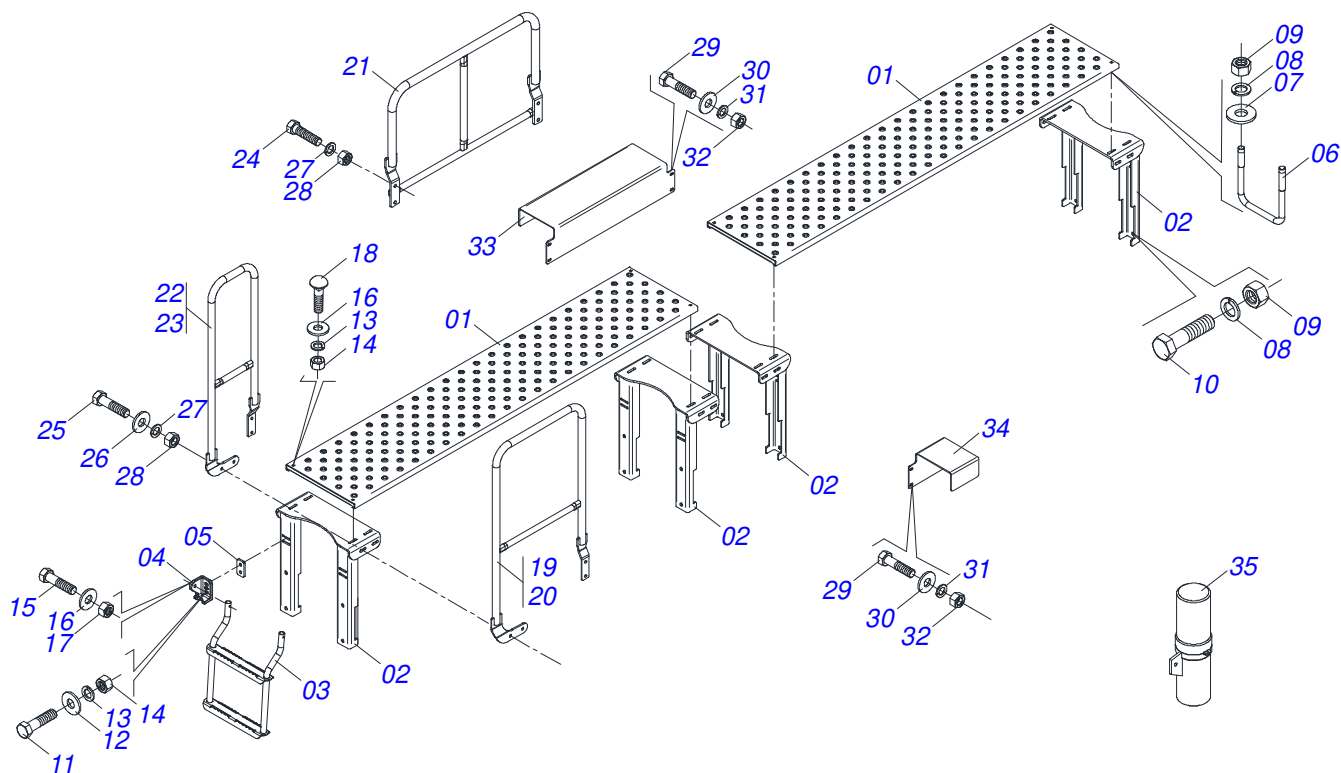

Item	Code	Description	See page	QT
01	0521064541	PLATFORM 2240 EST/MATIC 300		02
02	0521064915	SUPPORT PLATFORM ASSY		04
03	0511069636	LADDER		02
04	0502012742	FIXER SUPPORT LADDER		04
05	0571016087	FIXER PLATE LADDER		04
06	0571015203	5/8" X 4.33" X 3.46" HOLDER		08
07	0501812140	FLAT WASHER		16
08	0503010027	5/8" SPRING WASHER		32
09	0503010013	5/8" NUT		32
10	0503010762	SCREW 5/8 UNC X 3.1/2 CS G.5 ZN		16
11	0503010751	C3/8" X 1.1/4" HEX BOLT G.5		16
12	0501010984	FLAT WASHER 10,50 X 27 X 3,00 ZN		16
13	0503010025	3/8" SPRING WASHER		24
14	0503010026	3/8" NUT		24
15	0501010096	3/8" X 2" BOLT		04
16	0501010984	FLAT WASHER 10,50 X 27 X 3,00 ZN		12
17	0503013357	3/8" SELF-ADJUSTING NUT		04
18	0501011778	3/8" X 2-1/2" BOLT		08
19	0521064568	FRONT RIGHT HANDRAIL		01
20	0521064570	FRONT LEFT HANDRAIL		01
21	0521064569	HANDRAIL CENTRAL		01
22	0521064571	RIGHT REAR HANDRAIL		01
23	0521064572	RIGHT REAR HANDRAIL		01
24	0503010395	1/2" X 1-1/4" BOLT		12
25	0503010920	1/2" X 1.1/2" BOLT		08
26	0511017302	FLAT WASHER		08
27	0503010019	1/2" SPRING WASHER		20
28	0503010060	1/2" NUT		20
29	0503010371	5/16" X 1" BOLT		09
30	0501010984	FLAT WASHER 10,50 X 27 X 3,00 ZN		09
31	0503010179	LOCK WASHER		09



**EST/MATIC 300 - 15 ROD
PLATFORM ASSEMBLY**

Page 14
0909098767

Item	Code	Description	See page	QT
32	0503010337	5/16" NUT		09
33	0571014995	PROTECTION BODY		01
34	0571015211	PROTECTION BODY		01
35	0503060100	OPERATOR'S MANUAL STORAGE TUBE		01

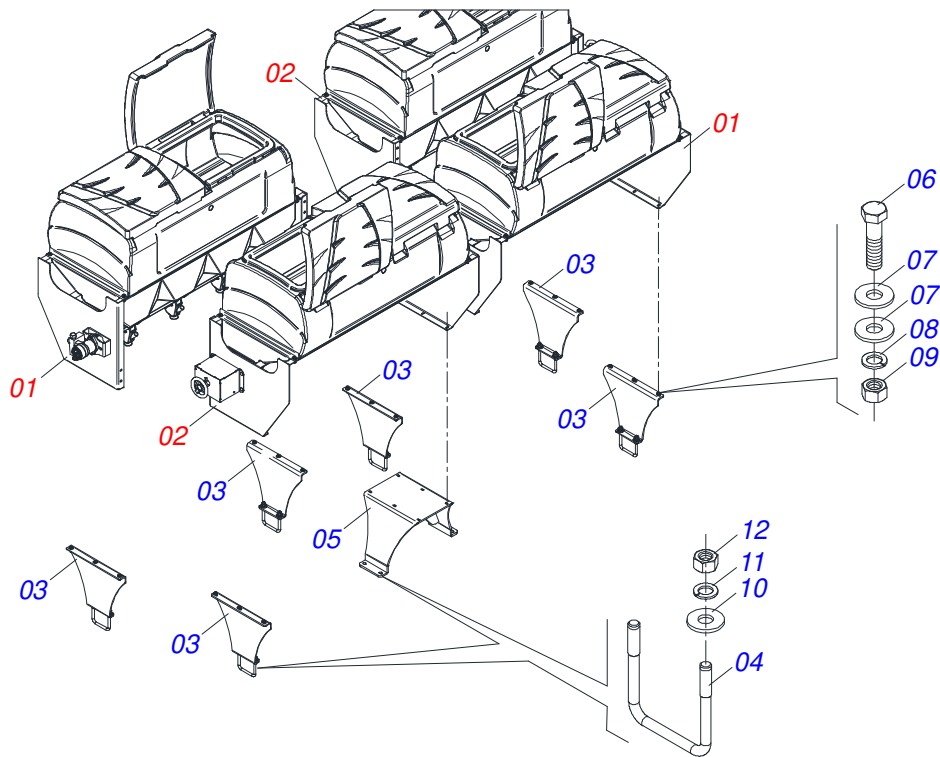

Item	Code	Description	See page	QT
01	0511054445	LEFT SUPPORT	16	02
02	0511054449	RIGHT SUPPORT	17	02
03	0571015098	FIXER SUPPORT SILO		06
04	0571015203	5/8" X 4.33" X 3.46" HOLDER		06
05	0521064916	CENTRAL BASE		01
06	0503010751	C3/8" X 1.1/4" HEX BOLT G.5		18
07	0501010984	FLAT WASHER 10,50 X 27 X 3,00 ZN		36
08	0503010025	3/8" SPRING WASHER		18
09	0503010026	3/8" NUT		18
10	0501812140	FLAT WASHER		08
11	0503010027	5/8" SPRING WASHER		08
12	0503010013	5/8" NUT		08

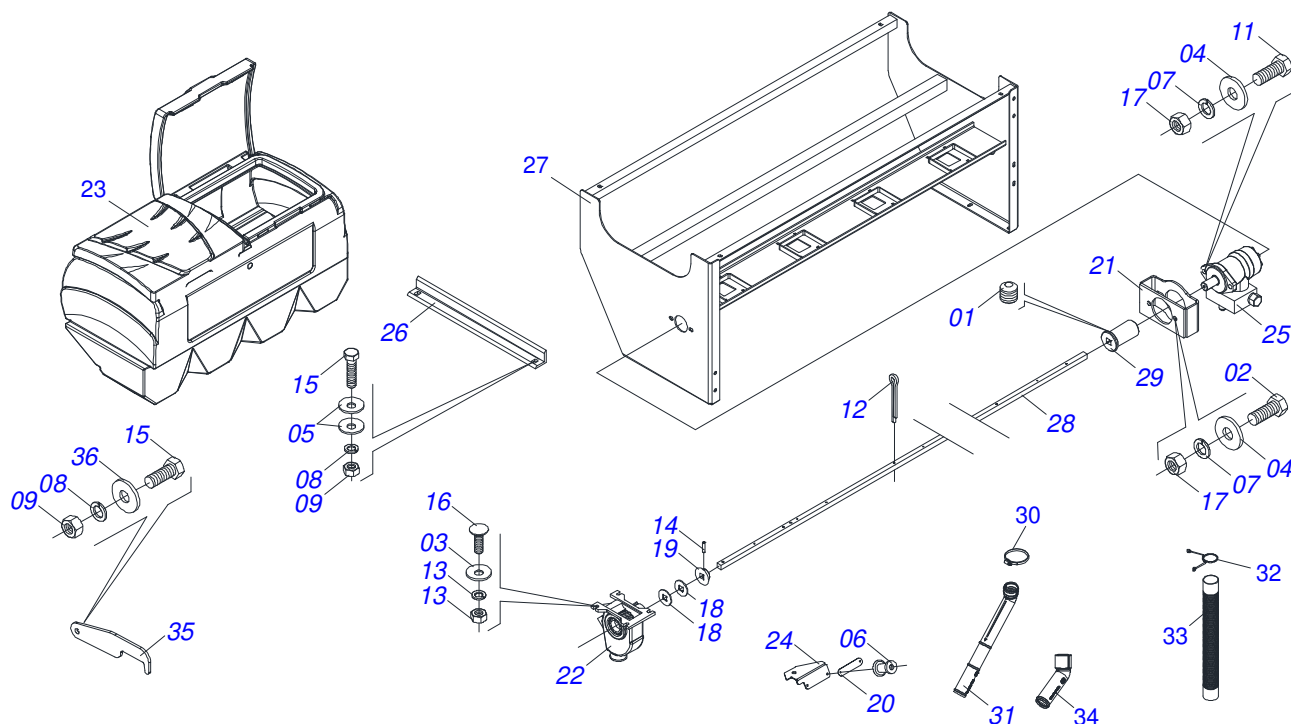

Item	Code	Description	See page	15
01	0503011136	BOLT 1/2 UNC X 1/2 S C S I 12.9		01
02	0501010161	1/2" X 1.1/4" BOLT		02
03	0501010694	FLAT WASHER		16
04	0501010937	13,50 X 28 X 3,00 FLAT WASHER		04
05	0501010984	FLAT WASHER 10,50 X 27 X 3,00 ZN		08
06	0503010001	3.2 X 5.5 RIVET		02
07	0503010019	1/2" SPRING WASHER		04
08	0503010025	3/8" SPRING WASHER		04
09	0503010026	3/8" NUT		04
10	0503010179	LOCK WASHER		16
11	0503010238	BOLT 1/2 UNC X 1.3/4 CS G.2 ZN		02
12	0503010257	1/8" X 1" COTTERPIN		08
13	0503010337	5/16" NUT		16
14	0503010561	SPRING PIN		01
15	0503010849	3/8" X 1-1/2" BOLT		05
16	0503011953	5/16" X 1" BOLT		16
17	0503010060	1/2" NUT		04
18	0541015361	FLAT WASHER		08
19	0503032423	LARGE DOSER		01
20	0503030886	SCALE DOSER		01
21	0511060346	FIXER MOTOR SUPPORT		01
22	0503032990	SEED DISTRIBUTOR BOX ASSY		04
23	0503061984	FERTILIZER HOPPER WITH 4 TRUNNELS		01
24	0561017360	SEED DOSADOR SCALE SUPPORT		01
25	0501053421	VALVE MOTOR HYDRAULIC ASSY	18	01
26	0571014996	ANGLE BAR		02
27	0521064514	SUPPORT LEFT BEAM SEED 04 MOUTHS		01
28	0571015000	MOTOR SHAFT		01
29	0521064390	SLEEVE		01
30	0503010246	CLAMP		04
31	0503031826	CURVED CONDUCTOR		02



LEFT SUPPORT

0511054445

Item	Code	Description	See page	15
32	0503031076	2" HOSE CLAMP		08
33	0503031145	2" X 2" X 20" HOSE		07
34	0503031826	CURVED CONDUCTOR		04
35	0571013134	LADDER LOCK		01
36	0511017302	FLAT WASHER		01

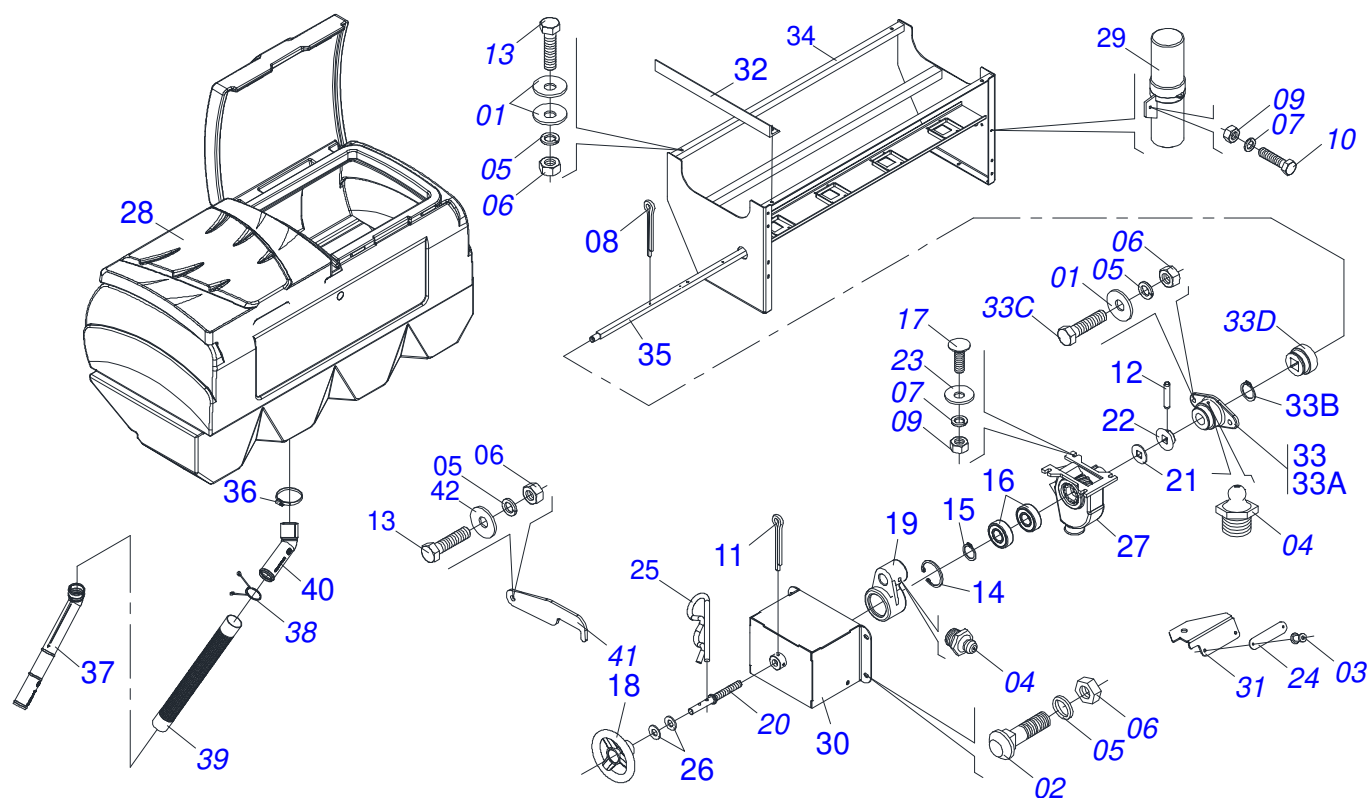

Item	Code	Description	See page	15
01	0501010984	FLAT WASHER 10,50 X 27 X 3,00 ZN	08	
02	0501011643	3/8 X 1" BOLT	04	
03	0503010001	3.2 X 5.5 RIVET	02	
04	0503010002	1800 GREASE FITTING	02	
05	0503010025	3/8" SPRING WASHER	08	
06	0503010026	3/8" NUT	08	
07	0503010179	LOCK WASHER	16	
08	0503010257	1/8" X 1" COTTERPIN	08	
09	0503010337	5/16" NUT	16	
10	0503010371	5/16" X 1" BOLT	09	
11	0503010523	1/4" X 2" COTTERPIN	01	
12	0503010561	SPRING PIN	01	
13	0503010849	3/8" X 1-1/2" BOLT	04	
14	0503011945	503050 CLAMPING RING (FOR AXLE)	01	
15	0503012104	501015 CLAMPING RING (FOR AXLE)	01	
16	0503012882	BEARING	02	
17	0503011953	5/16" X 1" BOLT	16	
18	0551019597	SEED REGULACION HANDLE	01	
19	0502012325	SEED REG BEARING	01	
20	0541015305	HANDLE SPINDLE	01	
21	0541015361	FLAT WASHER	08	
22	0503032423	LARGE DOSER	01	
23	0501010694	FLAT WASHER	16	
24	0503030886	SCALE DOSER	01	
25	0503031035	HITCH PIN CLIP	01	
26	0511015098	FLAT WASHER	02	
27	0503032990	SEED DISTRIBUTOR BOX ASSY	04	
28	0503061984	FERTILIZER HOPPER WITH 4 TRUNNELS	01	
29	0503060100	OPERATOR'S MANUAL STORAGE TUBE	01	
30	0521061856	HANDLE BOX FIXER WITH BUSHING	01	
31	0561017360	SEED DOSADOR SCALE SUPPORT	01	



RIGHT SUPPORT

0511054449

Item	Code	Description	See page	15
32	0571014996	ANGLE BAR		02
33	0511052896	BEARING		01
33A	0501110359	OUTER BEARING ASSY		01
33B	0503010372	501050 CLAMPING RING (FOR AXLE)		01
33C	0503010751	C3/8" X 1.1/4" HEX BOLT G.5		02
33D	0501079140	GEAR BODY		01
34	0521064512	SUPPORT RIGHT BEAM SEED 04 MOUTHS		01
35	0571014998	CONTROL AXLE		01
36	0503010246	CLAMP		04
37	0503031826	CURVED CONDUCTOR		02
38	0503031076	2" HOSE CLAMP		10
39	0503031145	2" X 2" X 20" HOSE		05
40	0503031050	CURVED CONDUCTOR		04
41	0571013134	LADDER LOCK		01

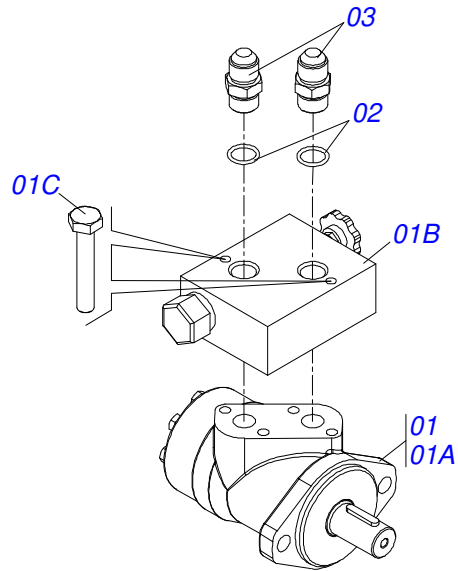

Item	Code	Description	See page	QT
01	0503012829	VALVE HYDRAULIC MOTOR ASSY		01
01A	0503014364	MOTOR W/ AXLE		01
01B	0503014365	VALVE		01
01C	0503010373	SCREW 1/4 UNC X 2 CS G.2 ZN		02
02	0503010045	O'RING		02
03	0501010590	NIPPLE		02

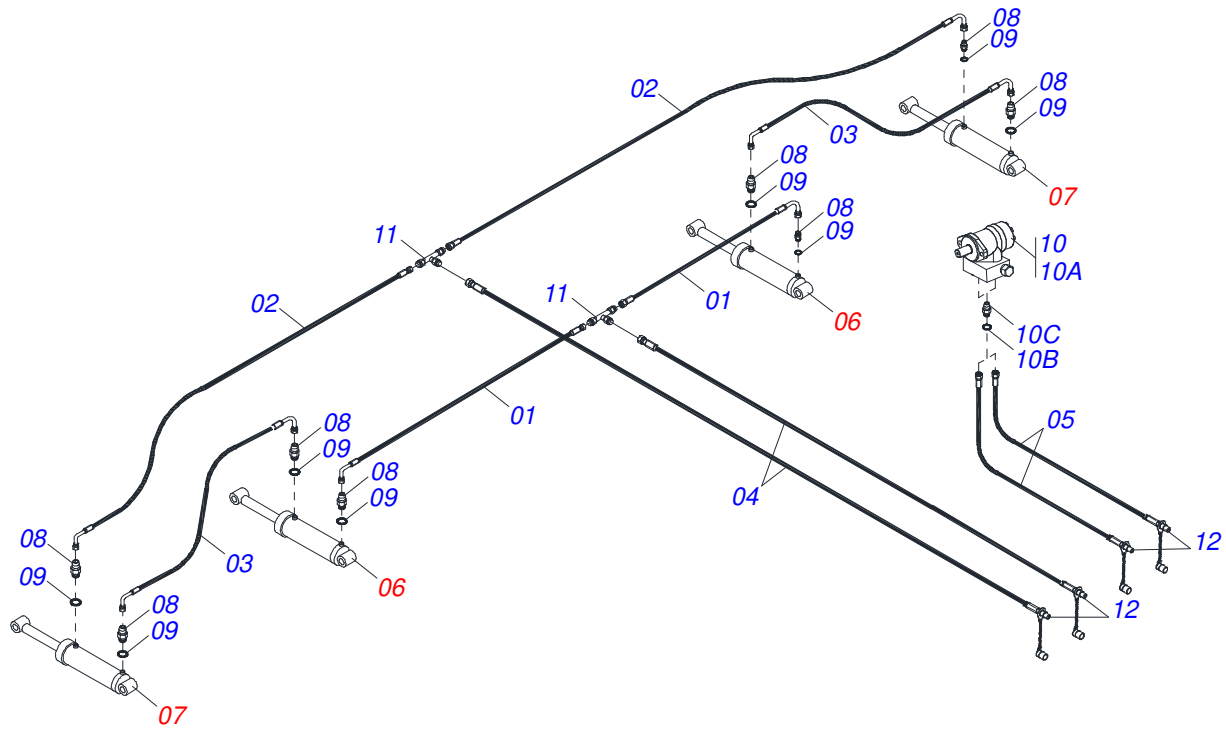

Item	Code	Description	See page	QT
01	0501080485	3/8 X 1100 TR-TC HOSE		02
02	0501080389	3/8" X 126" TC-TC HOSE ASSY		02
03	0501080359	3/8" X 78.7" TR-TC HOSE ASSY		02
04	0501080510	HOSE 3/8 X 3500 TR-TM		02
05	0501080350	HOSE 1/2 X 4500 TC-TM		02
06	0521040391	HYDRAULIC CYLINDER 53,98 X 101,6 X 515 X 203	4	02
07	0521040915	HYDRAULIC CYLINDER 44,45 X 85,7 X 515 X 203	5	02
08	0501010617	3/4" NIPPLE		08
09	0503010190	2-114 N 3006-9B O'RING		08
10	0501053421	VALVE MOTOR HYDRAULIC ASSY	18	01
10A	0503012829	VALVE HYDRAULIC MOTOR ASSY		01
10B	0503010045	O'RING		02
10C	0501010590	NIPPLE		02
11	0501072676	OIL DISTRIBUTOR BODY		02
12	0501053834	MALE QUICK COUPLER	23	04

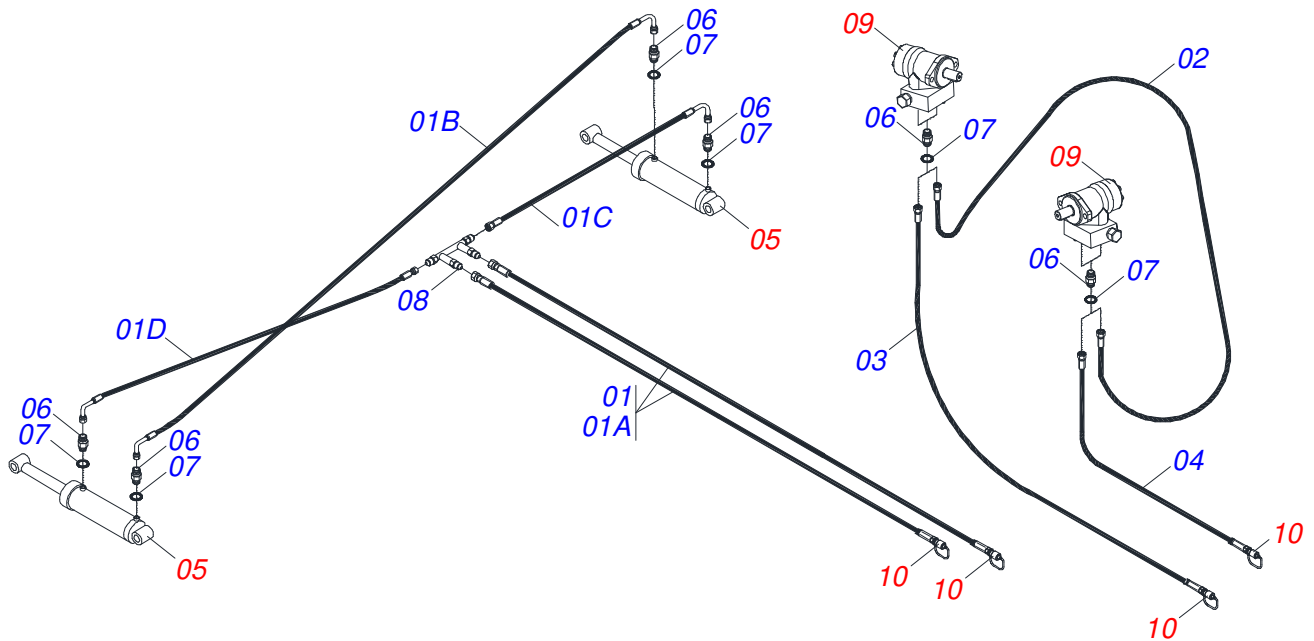

Item	Code	Description	See page	QT
01	0511053672	ASSY HOSE		01
01A	0501080384	TR-TM HOSE ASSY		02
01B	0501080746	TC-TC HOSE ASSY		01
01C	0501080436	3/8 X 1600 TR-TC HOSE		01
01D	0501080348	3/8 X 1200 TR-TC HOSE		01
01E	0503033158	PLASTIC BAG		01
02	0501081686	HOSE		01
03	0501081909	TR-TM HOSE ASSY		01
04	0501081911	HOSE 1/2 X 7500 TR-TM		01
05	0521040915	HYDRAULIC CYLINDER 44,45 X 85,7 X 515 X 203	5	02
06	0501010617	3/4" NIPPLE		04
07	0503010190	2-114 N 3006-9B O'RING		08
08	0501068088	OIL TUBE		01
09	0501053421	VALVE MOTOR HYDRAULIC ASSY	18	02
10	0501053834	MALE QUICK COUPLER	23	04

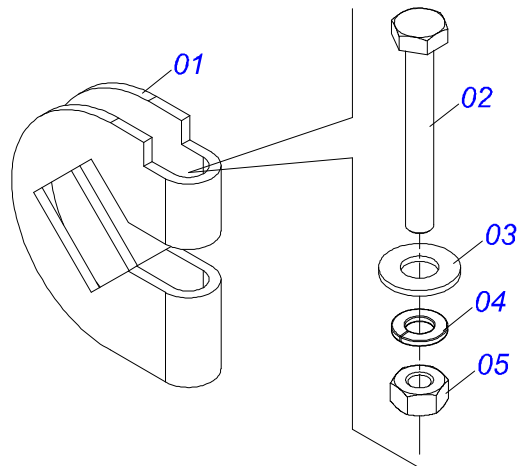

Item	Code	Description	See page	QT
01	0521010691	AXLE FASTENER		01
02	0503010373	SCREW 1/4 UNC X 2 CS G.2 ZN		01
03	0511017303	FLAT WASHER		01
04	0503010143	1/4" SPRING WASHER		01
05	0503010144	1/4" NUT		01

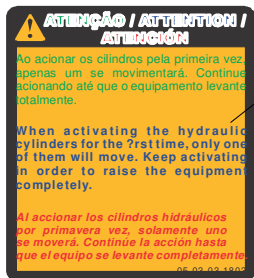

0503031803



0503031428



0503031087



0503034003



0503031827



0503010001

Item	Code	Description	See page	QT
01	0503031803	IMPORTANT ADHESIVE STICKER		01
02	0503031827	LUBRICATE AND RETIGHTEN DAILY DECAL		01
03	0503031428	READ MANUAL DECAL		01
04	0503031087	ADHESIVE LABEL		01
05	0503034003	SERIAL NUMBER TAG 61 X 118		01
06	0503010001	3.2 X 5.5 RIVET		01

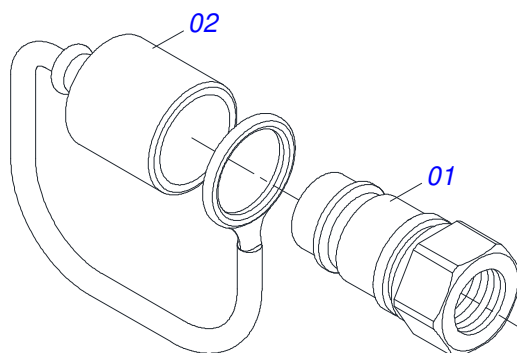

Item	Code	Description	See page	QT
01	0503011627	MALE QUICK COUPLER AGR 1/2 NPT		01
02	0503011882	MALE QUICK COUPLER CAP		01



MARCHESAN

Technical Publications | Elaboration and Revision

LUIZ CANDIDO

www.marchesan.com.br

