

ARADO DE DISCO/VERTEDERAS/TERRAZADORAS

ARPR - 05D

Código: 0501092367
Serie: S-0618
Revisión: 00
Fecha de Revisión: NOVIEMBRE/2018

CATALOGO DE PARTES



MARCHESAN



PRODUCTOS

Código	Descripción
0101030020	AR 5 X 28 X 6,00 PR S-0618
0101030021	AR 5 X 30 X 7,50 PR S-0618

ATENCIÓN: IMPORTANTE

Marchesan S.A. se reserva el derecho de perfeccionar y/o cambiar las características técnicas de sus productos, sin previo aviso y sin la obligación de proceder con los ya comercializados y sin conocimiento previo del revendedor o consumidor.



ÍNDICE

0909094934	CHASIS COMPLETO	1
0521045522	PEDESTAL	2
0521045524	PEDESTAL	3
0501043464	CILINDRO HIDRAULICO 38,1 X 63,5 X 350 X 145	4
0909094940	SOPORTE DE LA RUEDA COMPLETO	5
0909094942	CABECERA COMPLETA	6
0521053309	CONJUNTO PUERTA MANUAL INSTRUCCIÓN	7
0501053834	ACOPLAMIENTO RAPIDO MACHO AGRICOLA CON TAPA - 1/2 NPT	8

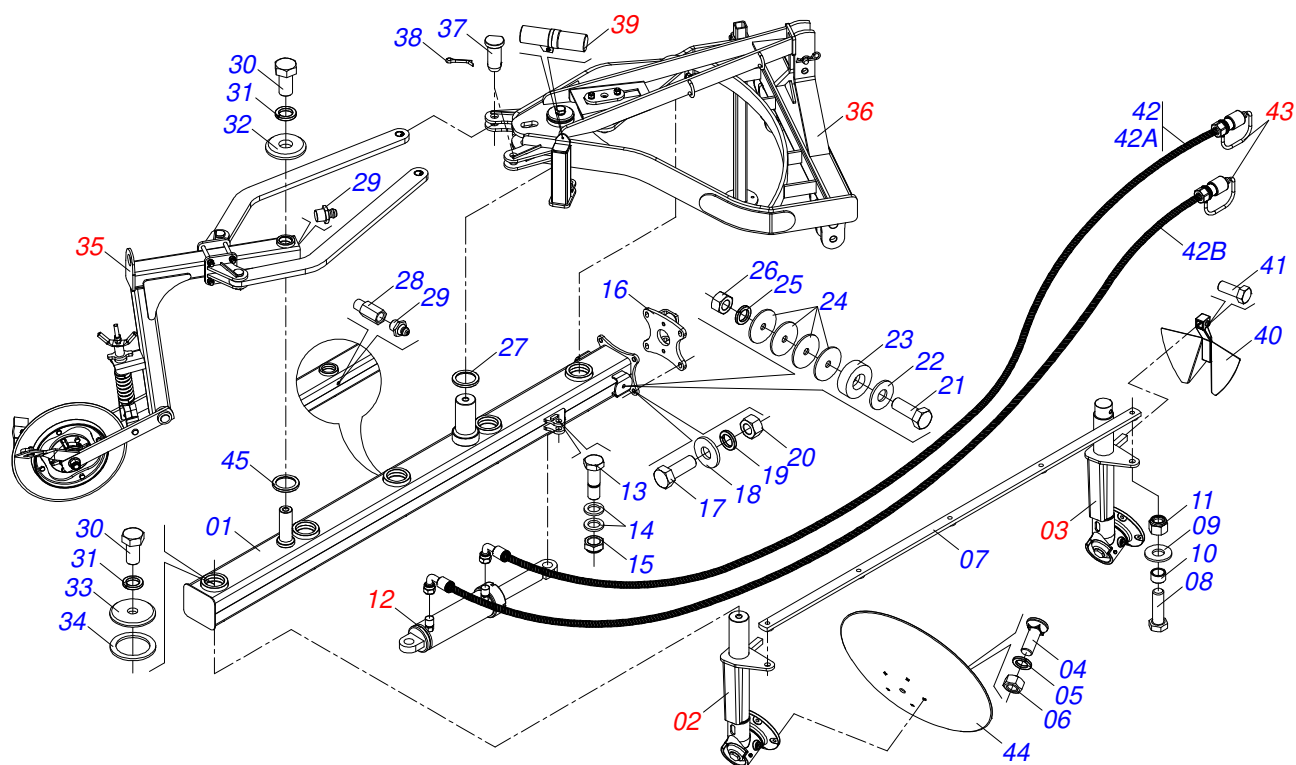

Artículo	Código	Descripción	Ver Pág.	QT
01	0521068701	CHASIS PUERTA DISCOS		01
02	0521045522	PEDESTAL	2	04
03	0521045524	PEDESTAL	3	01
04	0503012956	TORNILLO 1/2" BSW X 1.1/2"		25
05	0503010019	ARANDELA PRESION 1/2"		25
06	0503012682	TUERCA HEXAGONAL BSW 1/2"		25
07	0521068699	BARRA CONEXIÓN PEDESTAL		01
08	0501010125	TORNILLO 3/4" UNC X 2.1/2"		05
09	0501010322	ARANDELA PLANA 20.50 X 46 X 4.75		06
10	0581012830	GUANTE		05
11	0503011075	TUERCA		05
12	0501043464	CILINDRO HIDRAULICO 38,1 X 63,5 X 350 X 145	4	01
13	0581013463	EJE		02
14	0581012826	ARANDELA		04
15	0503014182	TUERCA		02
16	0521045525	SOPORTE CON ROLDANAS		01
17	0503810899	SCREW		04
18	0501812140	ARANDELA PLANA		04
19	0503011445	ARANDELA PRESION		04
20	0503010013	TUERCA 5/8		04
21	0503010899	TORNILLO 5/8 UNC X 2.1/4		02
22	0571010265	ARANDELA PLANA		02
23	0521011481	BATIDOR CHASIS		02
24	0571013284	ARANDELA PLANA		08
25	0503010027	ARANDELA PRESION		02
26	0503010013	TUERCA 5/8		02
27	0581812823	ARANDELA PLANA 85,30 X 114 X 12,50		01
28	0571016805	EXTENSOR		05
29	0503010002	GRASERA 1800		06
30	0503810953	TORNILLO 1 UNC X 2 C S		06
31	0503011438	ARANDELA PRESION		06



ARPR - 05D
CHASIS COMPLETO

Artículo	Código	Descripción	Ver Pág.	QT
32	0581012835	ARANDELA		01
33	0581012832	ARANDELA		05
34	0581012816	ARANDELA		04
35	0909094940	SOPORTE DE LA RUEDA COMPLETO	5	01
36	0909094942	CABECERA COMPLETA	6	01
37	0581012844	EJE		02
38	0503010571	PASADOR ABIERTO 1/4" X 1.1/2"		02
39	0521053309	CONJUNTO PUERTA MANUAL INSTRUCCIÓN	7	01
40	0521068700	LIMPIADOR DISCO		05
41	0501810161	TORNILLO 1/2 UNC X 1.1/4 C S G.2		05
42	0521053306	JUEGO MANGUERA		01
42A	0521053307	MANGUERA 3/8 X 2400 TC-TM MARRÓN / ROJA		01
42B	0521053308	MANGUERA 3/8 X 2200 TC-TM MARRON / AZUL		01
43	0501053834	ACOPLAMIENTO RAPIDO MACHO AGRICOLA CON TAPA - 1/2 NPT	8	02
44	0601042003	DISCO LISO P30 X 7,5		05
44.	0601039002	DISCO LISO 28 X 6		05
45	0581012836	ARANDELA		01

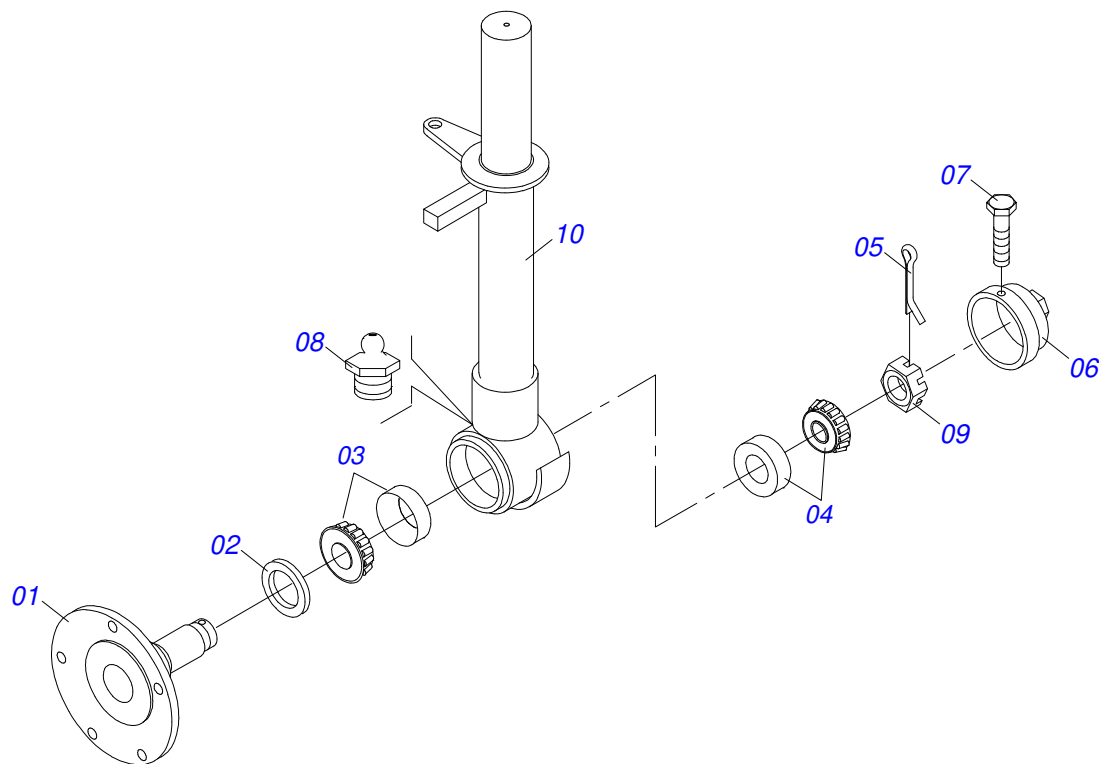

Artículo	Código	Descripción	Ver Pág.	QT
001	0502040091	PLATO DISCO		01
002	0503011866	RETEN 00573-B		01
003	0503010005	RODAMIENTO 32212		01
004	0503010006	RODAMIENTO 32210		01
005	0503010010	PASADOR ABIERTO 1/4 X 2.1/2		01
006	0502020597	TAPA PROTECCION		01
007	0503010358	TORNILLO 5/16 UNC X 7/8		01
008	0503010002	GRASERA 1800		01
009	0501010888	TUERCA CAST 1.3/4" 10FPP 2.5/16"		01
010	0521067286	PEDESTAL		01

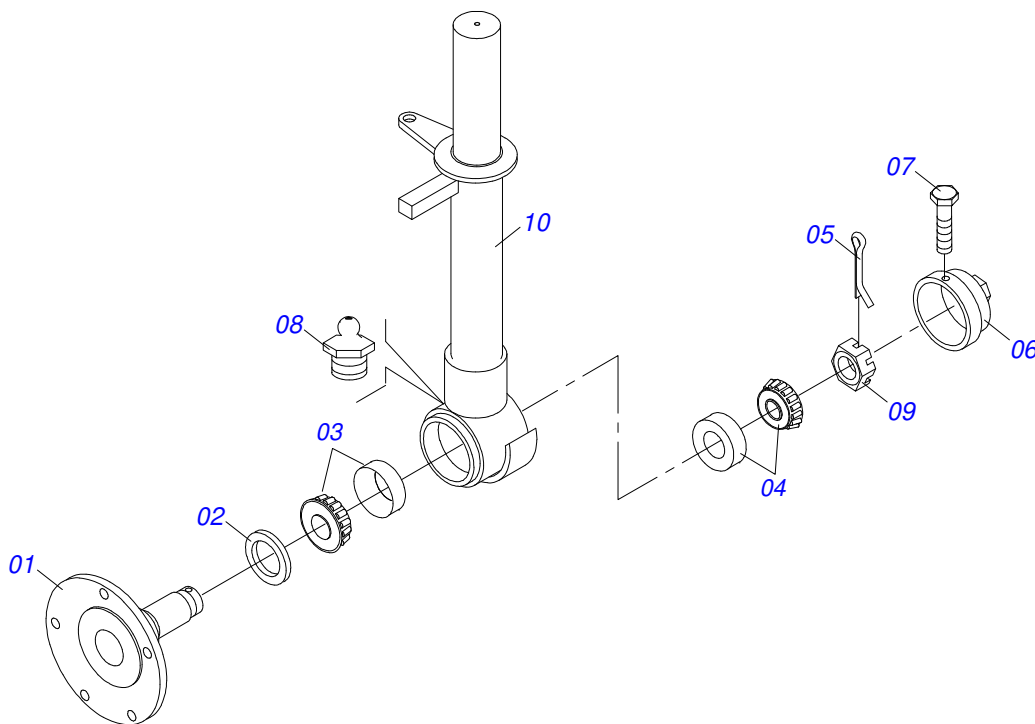

Artículo	Código	Descripción	Ver Pág.	QT
001	0502040091	PLATO DISCO		01
002	0503011866	RETEN 00573-B		01
003	0503010005	RODAMIENTO 32212		01
004	0503010006	RODAMIENTO 32210		01
005	0503010010	PASADOR ABIERTO 1/4 X 2.1/2		01
006	0502020597	TAPA PROTECCION		01
007	0503010358	TORNILLO 5/16 UNC X 7/8		01
008	0503010002	GRASERA 1800		01
009	0501010888	TUERCA CAST 1.3/4" 10FPP 2.5/16"		01
010	0521067287	PEDESTAL DIANT		01

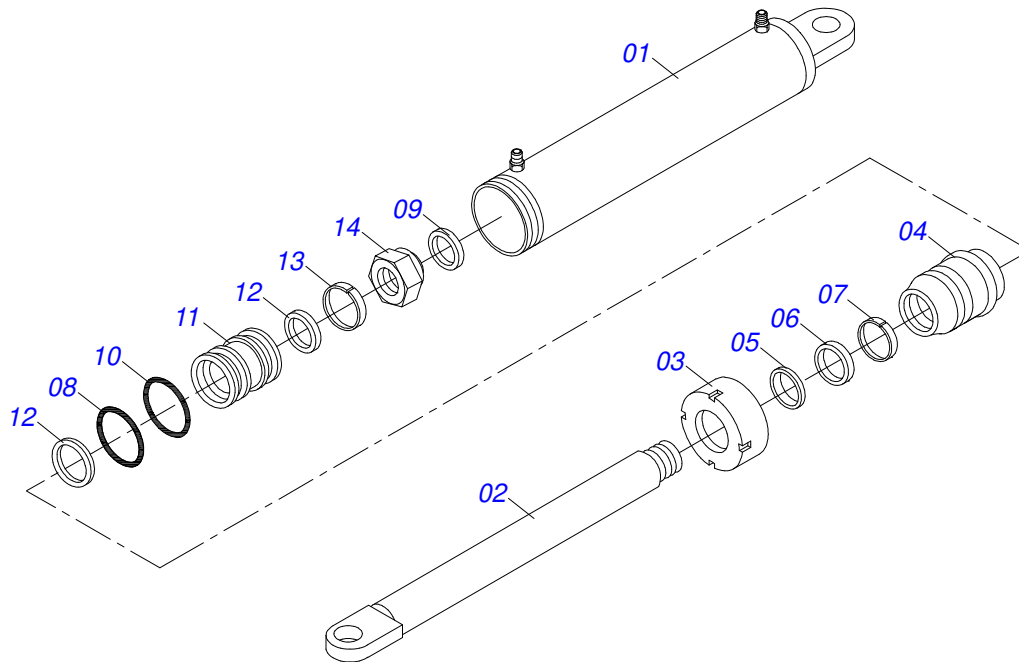

Artículo	Código	Descripción	Ver Pág.	QT
01	0501065175	CAMISA 63,50 X 293		01
02	0501069826	EXTENSOR CILINDRO HIDRAULICO		01
03	0502010471	TAPA MOVIL 63,50		01
04	0502010780	SOPORTE ANILLOS 38,1 X 63,		01
05	0503010163	ANILLO RASPADOR D-1500		01
06	0503010989	ANILLO 1870-1500-375-B		01
07	0503010970	ANILLO GUIA INTERNO W1-1650-500		01
08	0503011058	ANILLO BACK-UP 8-330		01
09	0503010161	ANILLO O'RING 2-330 N 3006 9B		01
10	0503010285	ANILLO O'RING 2-222 N 3006-9B		01
11	0502010783	EMBOLO 38 X 63,50		01
12	0503010160	ANILLO 2500 2000		02
13	0503010973	ANILLO GUIA EXTERNO W2-2500-500		01
14	0503010063	TUERCA 1" UNF		01
15	0501032666	JUEGO REPARO COMPL 38,10X63,50		01

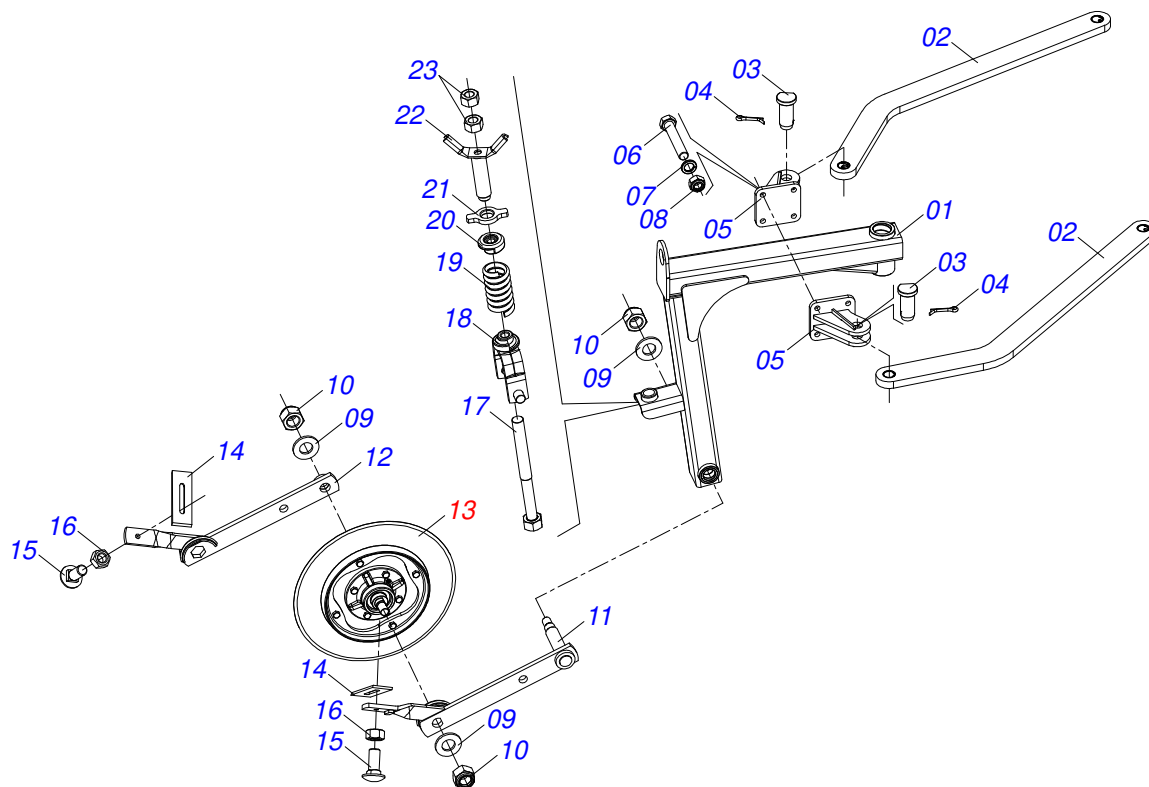

Artículo	Código	Descripción	Ver Pág.	QT
01	0521067302	SOPORTE DE LA RUEDA		01
02	0501110897	BAR COPIADORA RUEDA DE PROFUNDIDAD CON GUANTE 1085		02
03	0581812844	EJE JUNIÓN 31,75 X 57 AR-PR		02
04	0503010571	PASADOR ABIERTO 1/4" X 1.1/2"		02
05	0521067732	FIJACIÓN		02
06	0501013867	TORNILLO 5/8 UNC X 6 CS G.5 ZN		04
07	0503010027	ARANDELA PRESION		04
08	0503013389	TUERCA		04
09	0511815994	ARANDELA PLANA 26 X 50,80 X 4,75		03
10	0503010063	TUERCA 1" UNF		03
11	0501065203	BRAZO DERECHO RUEDA GU-A		01
12	0501065202	BRAZO IZQUIERDO RUEDAS GU-AS		01
13	0501043789	RODA GUIA COMPL		01
14	0511010353	LIMPIADOR DISCO		02
15	0501811600	TORNILLO 1/2 BSW X 1.1/4 CAPQ G.2		02
16	0503812682	TUERCA (BSW)		02
17	0501060108	ESPARRAGO 5/8" NC X 5/8" NC X 430		01
18	0501063497	HORQUILLA RESORTE		01
19	0503030441	RESORTE COMPRESION 68,5X145X12,70		01
20	1902040302	01		01
21	0541818672	CONTRA TUERCA		01
22	0501060107	TORNILLO REGULADOR		01
23	0503810013	NUT 5/8 NC		02

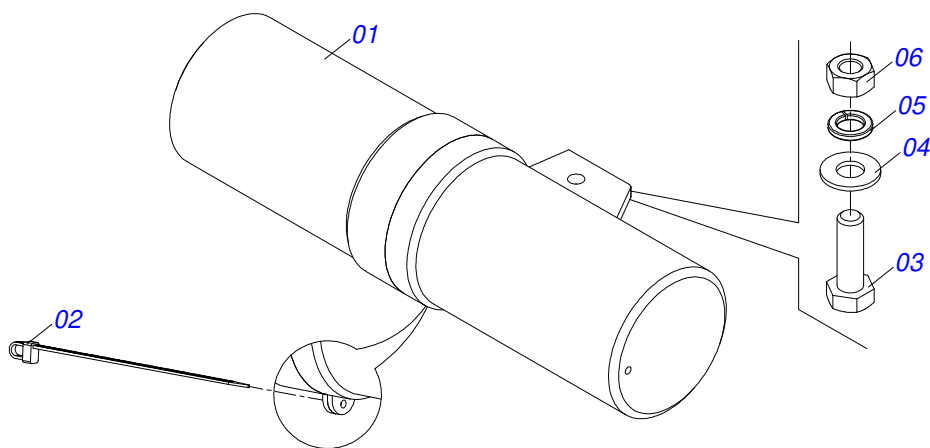

Artículo	Código	Descripción	Ver Pág.	QT
01	0503060100	COMPARTIMIENTO DEL MANUAL		01
02	0503010267	ABRAZADERA NYLON		01
03	0503010363	TORNILLO 5/16 UNC X 1		01
04	0501010694	ARANDELA PLANA		01
05	0503010179	ARANDELA PRESION		01
06	0503010337	TUERCA 5/16		01

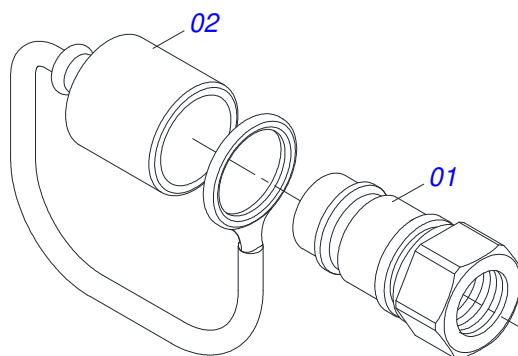

Artículo	Código	Descripción	Ver Pág.	QT
01	0503011627	MACHO ENGANCHE RAP AGR 1/2 NPT		01
02	0503011882	TAPA PLASTICA P/ ENG RAP		01

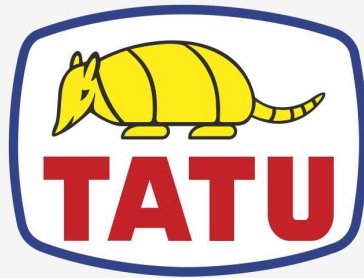

MARCHESAN

Publicaciones Técnicas | Elaboración y Revisión

ALESSANDRA PATRICIA KAWAHARA CARRILI

www.marchesan.com.br

