

PARTS CATALOG

DOUBLE OFFSET DISK HARROW

GH 16D

Code: 0501092228



Series: S-0178

Rev.: 00

Date Rev.: JUNHO/2018

**ORIGINAL PARTS
TATU**



PRODUCTS

Code	Description
0102190211	GH 16 X 20 X 3,50 MA MT S/DISCO
0102190062	GH 16 X 18 X 3,00 CM MT S-0178
0102190246	GH 16 X 18 X 3,00 DM MT S-0178
0102190016	GH 16 X 18 X 3,00 MA DR S-0178
0102190001	GH 16 X 18 X 3,00 MA MT S-0178
0102190068	GH 16 X 18 X 3,00 MA MT AGR S-0178
0102190027	GH 16 X 18 X 3,50 MA DR S-0178
0102190079	GH 16 X 18 X 3,50 MA MT S-0178
0102190175	GH 16 X 20 X 3,50 CM DR S-0178
0102190082	GH 16 X 20 X 3,50 CM MT S-0178
0102190184	GH 16 X 20 X 3,50 MA DR S-0178
0102190002	GH 16 X 20 X 3,50 MA MT S-0178
0102190093	GH 16 X 20 X 3,50 MA MT AGR S-0178
0102190136	GH 16 X 20 X 4,00 MA MT S-0178
0102190069	GH 16 X 20 X 4,00 MA MT AGR S-0178
0102190102	GH 16 X 22 X 4,50 CM MT S-0178
0102190145	GH 16 X 22 X 4,50 DM MT S-0178
0102190103	GH 16 X 22 X 4,50 MA MT S-0178
0102190013	GH 16 X 22 X 4,50 MA MT AGR S-0178
0102190014	GH 20 X 22 X 4,50 MA MT AGR S-0178

ATTENTION: **IMPORTANT**

MARCHESAN S/A RESERVES THE RIGHT AT ANY TIME TO MAKE IMPROVEMENTS IN THE DESIGN, MATERIAL OR SPECIFICATIONS OF MACHINERY, EQUIPMENT OR PARTS WITHOUT THEREBY BECOMING LIABLE TO MAKE SIMILAR CHANGES IN MACHINERY, EQUIPMENT OR PARTS PREVIOUSLY SOLD.

INDEX

0909094194	FRAME ASSY	1
0909094195	GANG DISC	2
0501040132	FRICION BEARING ASSY	3
0501046912	CM GX 7" Q 1 PR BEARING ASSY	4
0501046921	7.5" Q1" OIL BATH BEARING	5

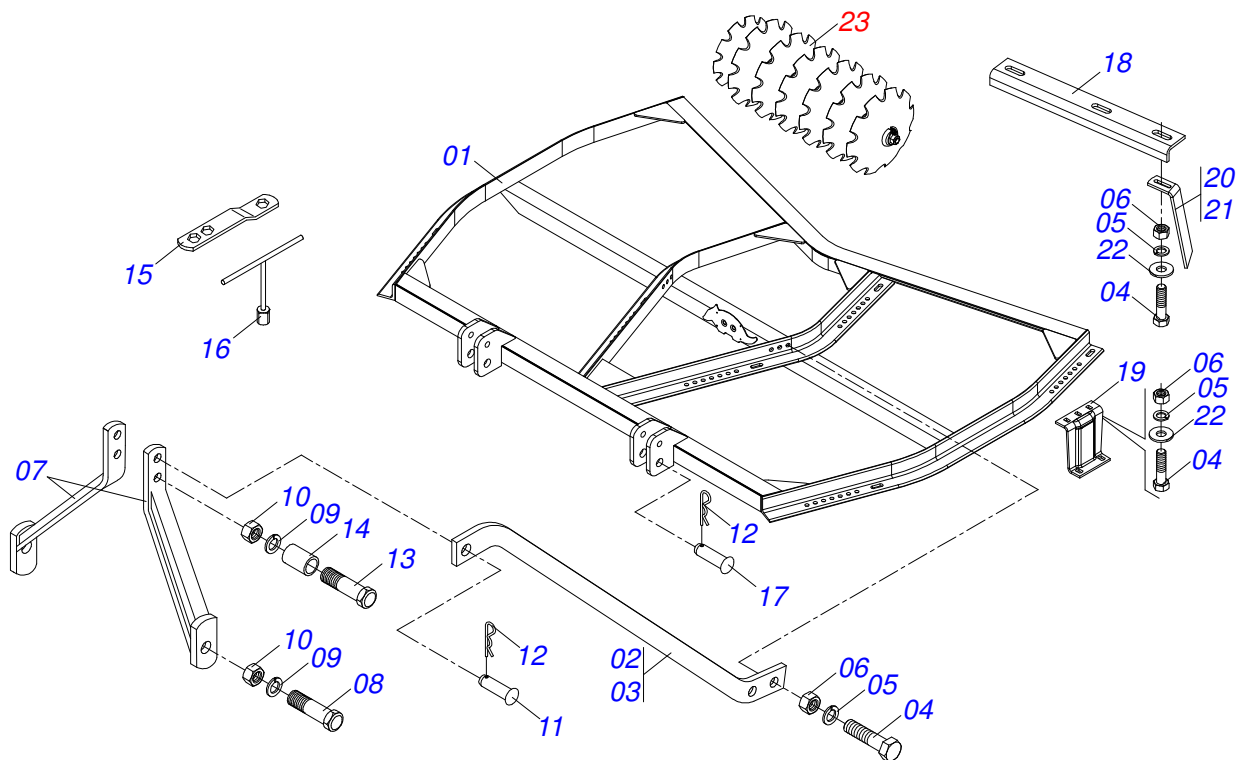

Item	Code	Description	QT
01	0501065765	FRAME	01
02	0501010404	RIGHT ATTACHMENT BAR	01
03	0501010407	LEFT ATTACHMENT BAR	01
04	0503011082	C1/2" X 1.3/4" BOLT	04
05	0503010019	1/2" SPRING WASHER	40
06	0503010060	1/2" NUT	40
07	0551010920	DRAWBAR	02
08	0501018059	3/4" X 2-1/4" BOLT	02
09	0503010023	SPRING WASHER	03
10	0503010014	3/4" NUT	03
11	0521010579	COUPLING SHAFT	01
12	0503031035	HAIR PIN	03
13	0503011198	C3/4" X 6" BOLT	01
14	0521010490	SLEEVE SPACER	01
15	0511018451	5/8" X 3/4" X 1" UNIVERSAL	01
16	0501068289	5/8" WRENCH T	01
17	0521010595	1.1" X 4.3" COUPLING SHAFT	02
18	0511011999	19.5" BAR OF THE FIX OF THE SCRAPER	04
19	0501010451	BRACKET	08
20	0511014512	FRONT SCRAPER GH	02
21	0511014511	REAR SCRAPER GH	02
22	0511017302	FLAT WASHER	40
23	0909094195	GANG DISC	01

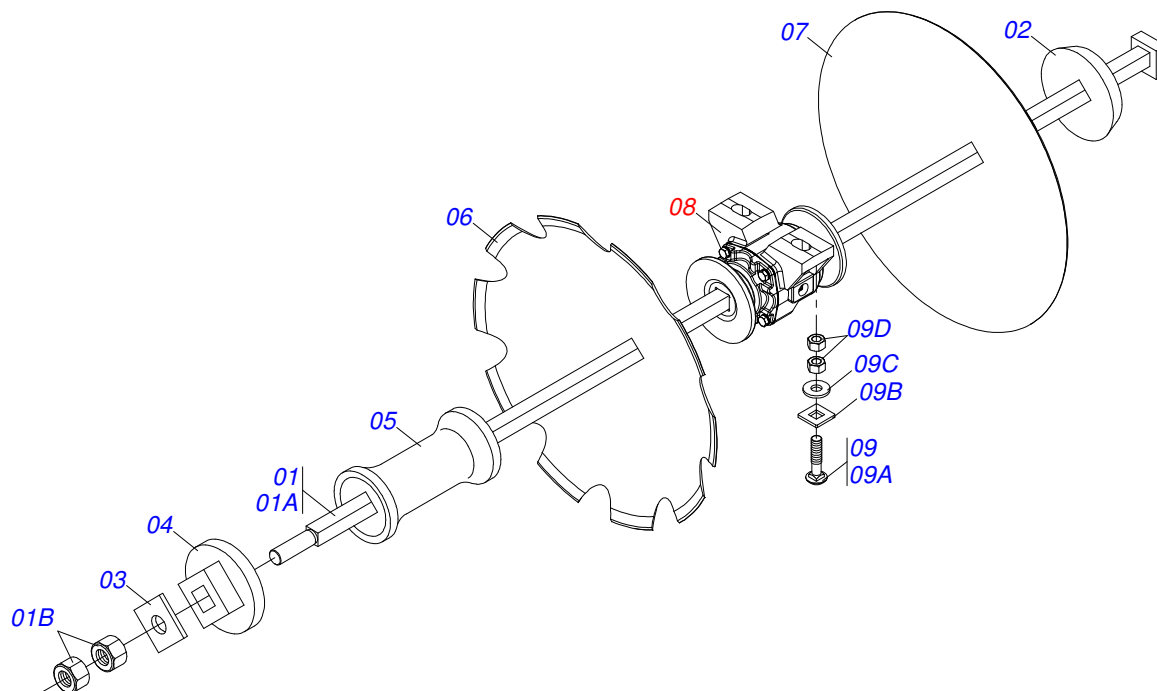

Item	Code	Description	QT
01	0501040681	1" X 27.7" SQUARE AXLE WITH NUTS	04
01A	0501010441	1" X 27.7" SQUARE SHAFT	04
01B	0501010059	1.5/8 NUT	08
02	0502010075	EXTERNAL AXLE WASHER	04
03	0501010450	NUT LOCK	04
04	0502010076	INNER AXLE WASHER FQ	04
05	0502010933	192,5 SPACER	04
06	0602025078	DR18X3 C44AF02FC26,59 9REC L.M.	08
06.	0602025180	DR18X3,5 C44AF02FC1.1/16 9REC JUMIL	16
06..	0602027230	DR20X3,5 C57AF02FC1.1/16 10RE JUMIL	16
06...	0602027353	DR20X4 C57AF02FC1.1/16 10REC TATU	08
06....	0602029424	DR22X4,5 C64AF02FC1.1/16 10REC TATU	08
07	0601025166	DL18X3 C45AF02FC1.1/16 JUMIL	01
07.	0601025254	DL18X3,5 C45AF02FC1.1/16 TATU	08
07..	0601027184	DL20X3,5 C57AF02FC1.1/16 9901022 JU	08
07...	0601027283	DL20X4 C57AF02FC1.1/16 D094	08
07....	0601029103	DL22X4,5 C63AF02FC26,59 FT	08
08	0501040132	FRICTION BEARING ASSY	08
08.	0501046912	CM GX 7" Q 1 PR BEARING ASSY	08
08..	0501046921	7.5" Q1" OIL BATH BEARING	08
09	0501048788	CONJUNTO PCS IMPL 5/8 UNC X 2.1/2 CA	16
09A	0501014177	5/8" X 2-1/2" BOLT	16
09B	0501010947	5/8 NUT LOCK	16
09C	0501012140	FLAT WASHER	16
09D	0503010013	5/8" NUT	32

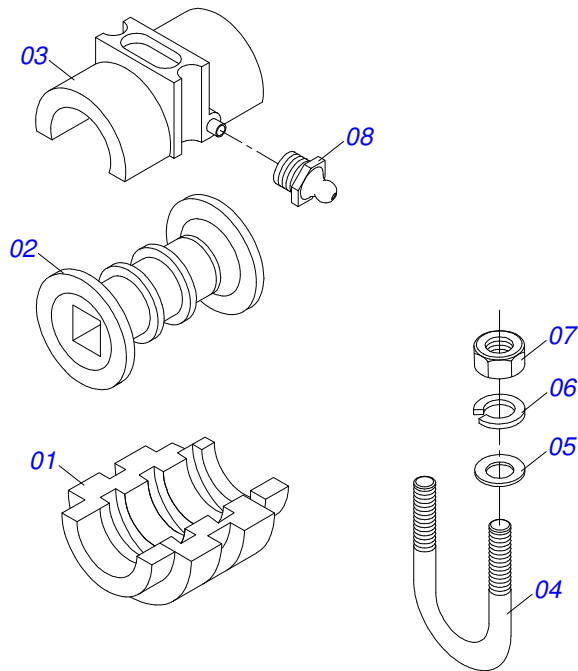

Item	Code	Description	QT
01	0502030006	LOWER COVER HOUSING	01
02	0502030011	REEL	01
03	0502030004	UPPER COVER HOUSING	01
04	0521012326	5/8 UNC X 138 X 117 FASTENER	01
05	0501012140	FLAT WASHER	02
06	0503010027	SPRING WASHER	02
07	0503010013	5/8" NUT	02
08	0503010002	1800 GREASE FITTING	01

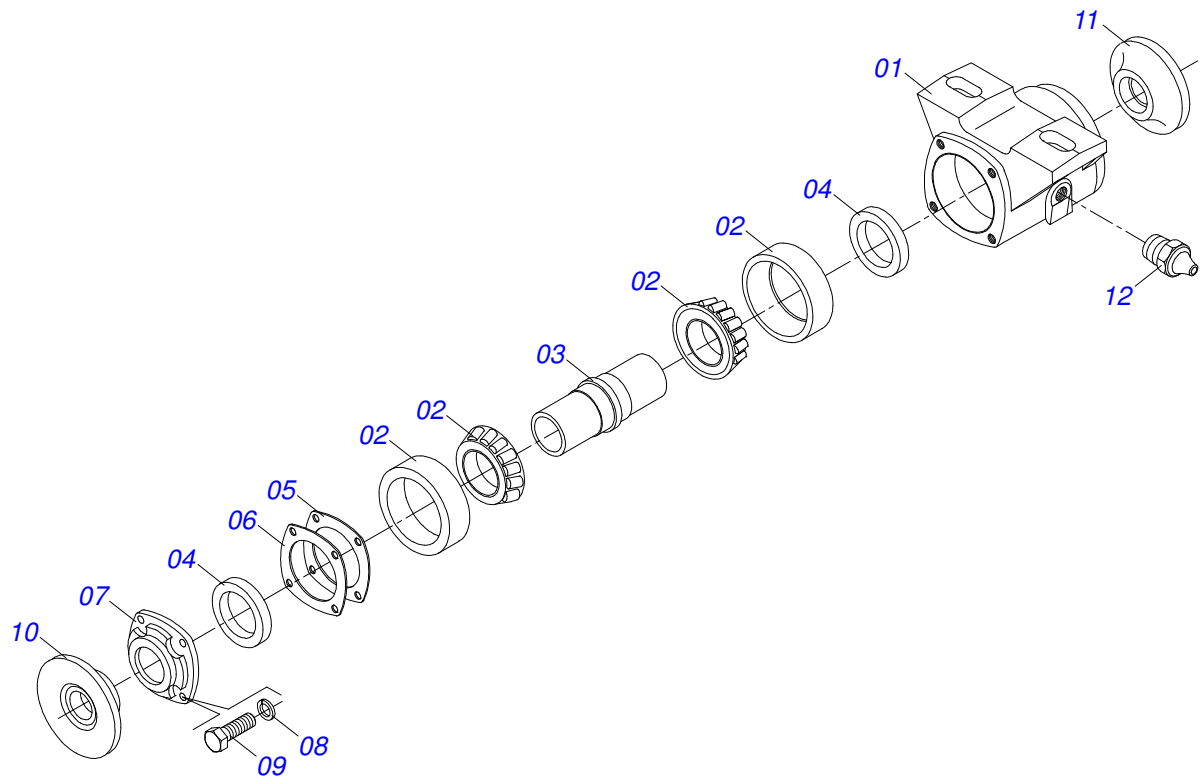

Item	Code	Description	QT
01	0502020313	HOUSING CM	01
02	0503010111	30210 ROLLER BEARING	02
03	0502040381	AXLE	01
04	0503010468	SEAL 01199-GB	02
05	0503030013	4.4" X 3.5" X 0.004" JOINT	02
06	0503030684	4.4" X 3.5" X 0.004" JOINT	01
07	0502020273	HOUSING CAP CM	01
08	0503011443	SPRING WASHER	04
09	0503011087	3/8" X 1" BOLT	04
10	0502010297	OUTER FLANGE	01
11	0502010298	INNER FLANGE	01
12	0503010002	1800 GREASE FITTING	01

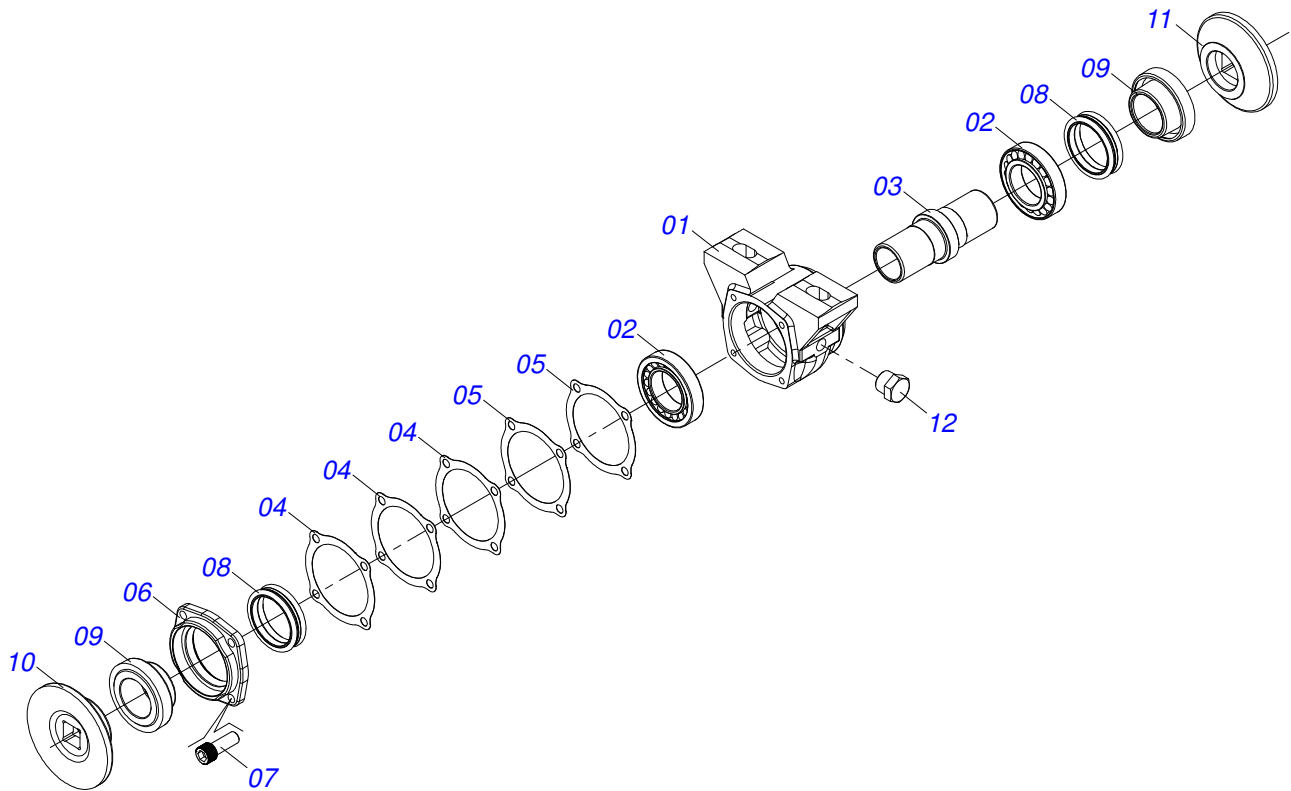

Item	Code	Description	QT
01	0502010540	HOUSING DM	01
02	0503010111	30210 ROLLER BEARING	02
03	0502040381	AXLE	01
04	0503030013	4.4" X 3.5" X 0.004" JOINT	03
05	0503030684	4.4" X 3.5" X 0.004" JOINT	02
06	0502020424	HOUSING CAP DM	01
07	0503010134	3/8" X 1" BOLT	04
08	0503030026	SEAL LP JB-253	02
09	0502010541	SEAL RETAINER	02
10	0502010297	OUTER FLANGE	01
11	0502010298	INNER FLANGE	01
12	0503010856	OIL PLUG	01



MARCHESAN IMPLEMENTOS E MÁQUINAS AGRÍCOLAS TATU S.A.

AV. Marchesan, 1979 - Post office box, 131 - CEP 15994-900 - Matão - SP - Brazil

Phone +55 16.3382-8282

(FAX Parts) + 55 16.3382. 8297 - (Export) + 55 16.3382.1003

e.mail: tatu@marchesan.com.br www.marchesan.com.br

Technical Publications: Elaboration

ALESSANDRA PATRICIA KAWAHARA CARRILI

Technical Publications: Revision

ALESSANDRA PATRICIA KAWAHARA CARRILI

Contact Catálogo:

E-mail = jgaspari@marchesan.com.br

**ORIGINAL PARTS
TATU**

