

CATÁLOGO DE PIEZAS

PALAS DELANTERAS

PD MF 4292-4 SHT/BT TC-ZF/CA
S-0510

Código: 0501091486



Serie: S-0510

Revisión: SETEMBRO/15

PIEZAS ORIGINALES
TATU



INDICE

0909090754	CHASSI PD MF 4292-4 S-0510	1
0909090756	SUPT.MOVEL MF 4292-4 BT/SHT S-0510	2
0909090758	CIRC.HIDR. MF 4292-4 BT S-0510	3
0909090759	CIRC.HIDR. 4292-4 SHT TC-ZF/CA S-0510	4
0909090760	CIL.HIDR.44,45X85,7X1010X400 DIR/ESQ.	5

ATENCIÓN: **IMPORTANTE**

MARGHESAN SE RESERVA EL DERECHO DE PERFECCIONAR Y/O MODIFICAR LAS CARACTERÍSTICAS TÉCNICAS DE SUS PRODUCTOS, SIN LA OBLIGACIÓN DE PROCEDER CON LOS YA COMERCIALIZADOS Y SIN CONOCIMIENTO PREVIO DEL DISTRIBUIDOR AUTORIZADO O DEL CONSUMIDOR.

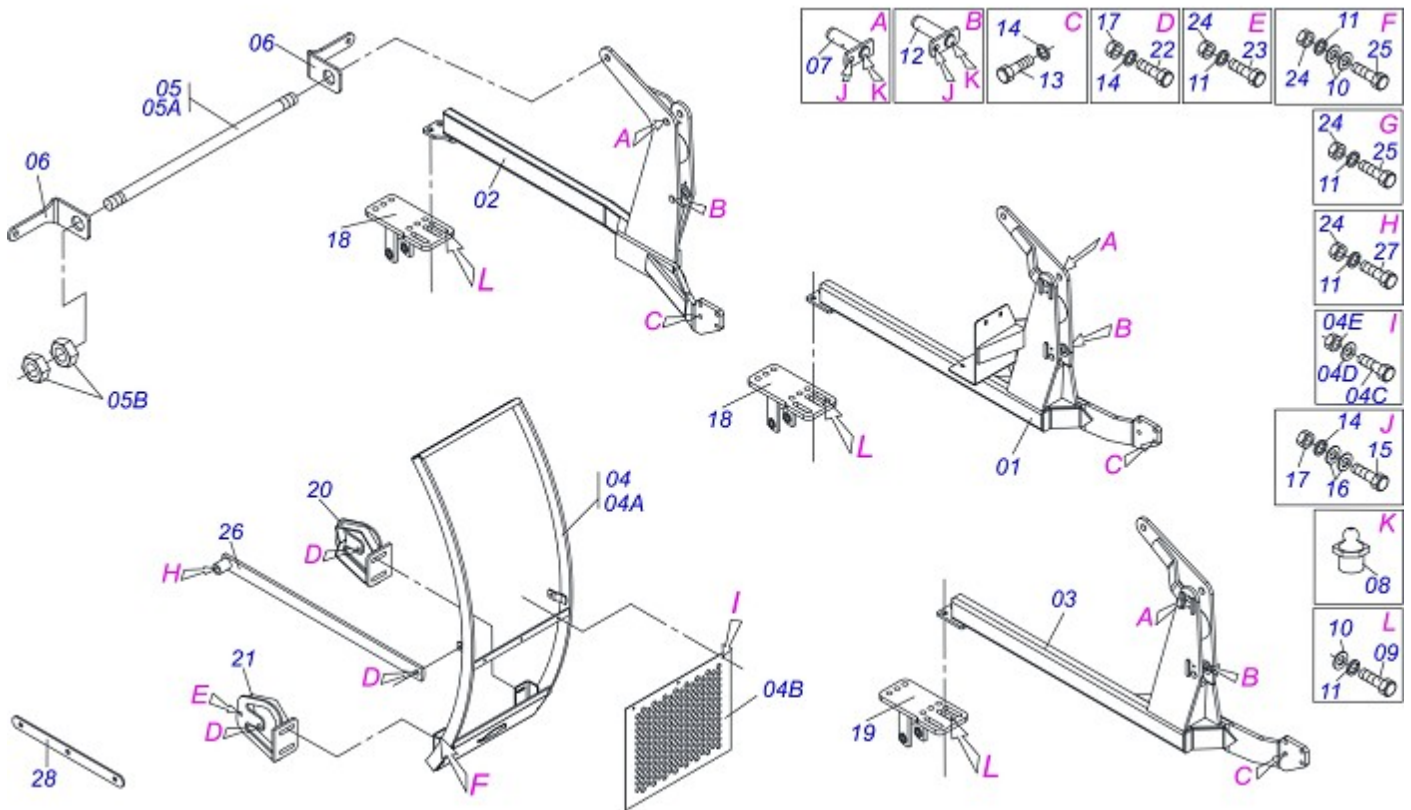

Artículo	Código	Descripción	QT
01	0521061634		01
02	0521061635		01
03	0521061636		01
04	0511049956	GUIA SOPORTE MOVIL COMPL	01
04A	0521062696		01
04B	0501017431	PROTECCIÓN DELANTERA	01
04C	0503010751	TORNILLO 3/8" UNC X 1.1/4"	03
04D	0501010984	ARANDELA PLANA	03
04E	0503010026	TUERCA 3/8"	03
05	0511043351	VARON 1.1/4 NC X 1000	01
05A	0541015018		01
05B	0501010087	TUERCA 1.1/4" UNC 7FPP	04
06	0561010051		02
07	0501063751	EJE ARTIC 37,2 X 140	02
08	0503010002		02
09	0503010962		04
10	0501012140	ARANDELA PLANA	08
11	0503010027		10
12	0501063960	EJE ARTIC TRABA 37,2 X 130	02
13	0503013390	TORNILLO 3/4" UNC X 2.1/2	12
14	0503010023		10
15	0501010500	TORNILLO 3/4" UNC X 3"	04
16	0501010322		08
17	0503010014		06
18	0511069461		01
19	0511069462		01
20	0521061644		01
21	0521061643		01
22	0503011322	TORNILLO M20 X 2,5 X 50	02
23	0501010100	TORNILLO 5/8" UNC X 2"	02
24	0503010013		06
25	0503010233	TORNILLO 5/8" UNC X 2.1/2"	04
26	0521063340		02



PD MF 4292-4 SHT/BT TC-ZF/CA S-0510

Página 1

CHASSI PD MF 4292-4 S-0510

0909090754

Artículo	Código	Descripción	QT
27	0503016110	SOPORTE LINEA ABONO LONGA	02
28	0561016347		02

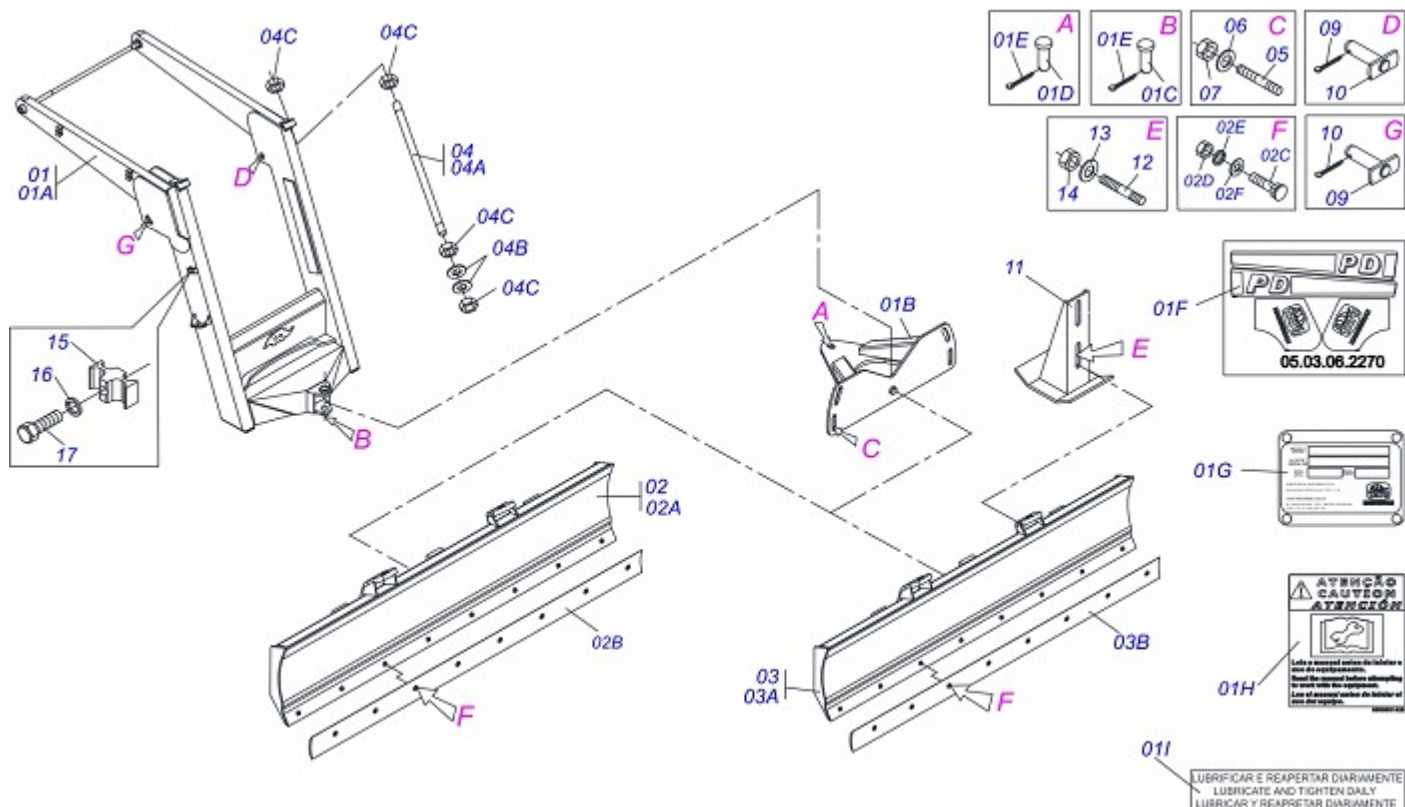

Artículo	Código	Descripción	QT
00	0909090756	SUPT.MOVEL MF 4292-4 BT/SHT S-0510	01
01	0511049953		01
01A	0521062701		01
01B	0501062637	SOPORTE REGULACION	01
01C	0521010618	EJE UNION 37,50 X 220	01
01D	0521010612	EJE UNION 37,50 X 90	01
01E	0503010010	PASADOR ABIERTO 1/4 X 2.1/2	02
01F	0503062270	CONJUNTO DE ETIQUETAS ADHESIVAS	01
01G	0503034003		01
01H	0503031428	ETIQUETA ADHESIVA ATENCIÓN	01
01I	0503031827	ETIQUETA ADHESIVA	01
02	0501047708	SOPORTE CUCHILLA 2400	01
02A	0501067999	SOPORTE CUCHILLA 2390	01
02B	0622360016	RASPADOR REVERSIBLE 2400	01
02C	0501012240	TORNILLO 5/8" UNC X 2.1/2"	08
02D	0503010013		08
02E	0503010027		08
02F	0501012140	ARANDELA PLANA	08
03	0501047710	SOPORTE CUCHILLA 2600 COMPL	01
03A	0501068001	SOPORTE CUCHILLA 2590	01
03B	0622360011	RASPADOR REVERSIBLE 2400	01
04	0501041427	VARON 1.1/4" NC X 1540	02
04A	0501014250	VARON 1.1/4" X 1540	02
04B	0502012180	ARANDELA TENSORA	04
04C	0501010087	TUERCA 1.1/4" UNC 7FPP	08
05	0561016755	PRISIONERO 1 UNC X 1 UNC X 76 ZN	04
06	0501010574	ARANDELA PLANA	04
07	0501010059		04
08	0521063354	EJE UNION	01
09	0521063358		01
10	0503010534	03	02
11	0501063411	ZAPATA ESTAB	02
12	0561016756	PRISIONERO 3/4 UNC X 3/4 UNC X 56	04



Artículo	Código	Descripción	QT
13	0501010322		04
14	0503010014		04
15	0502012702	CUERPO SUPERIOR PRESILLA 7/16	03
16	0503012555	TORNILLO 7/16" UNC X 2"	03
17	0503010180	ARANDELA PRESION 7/16"	03

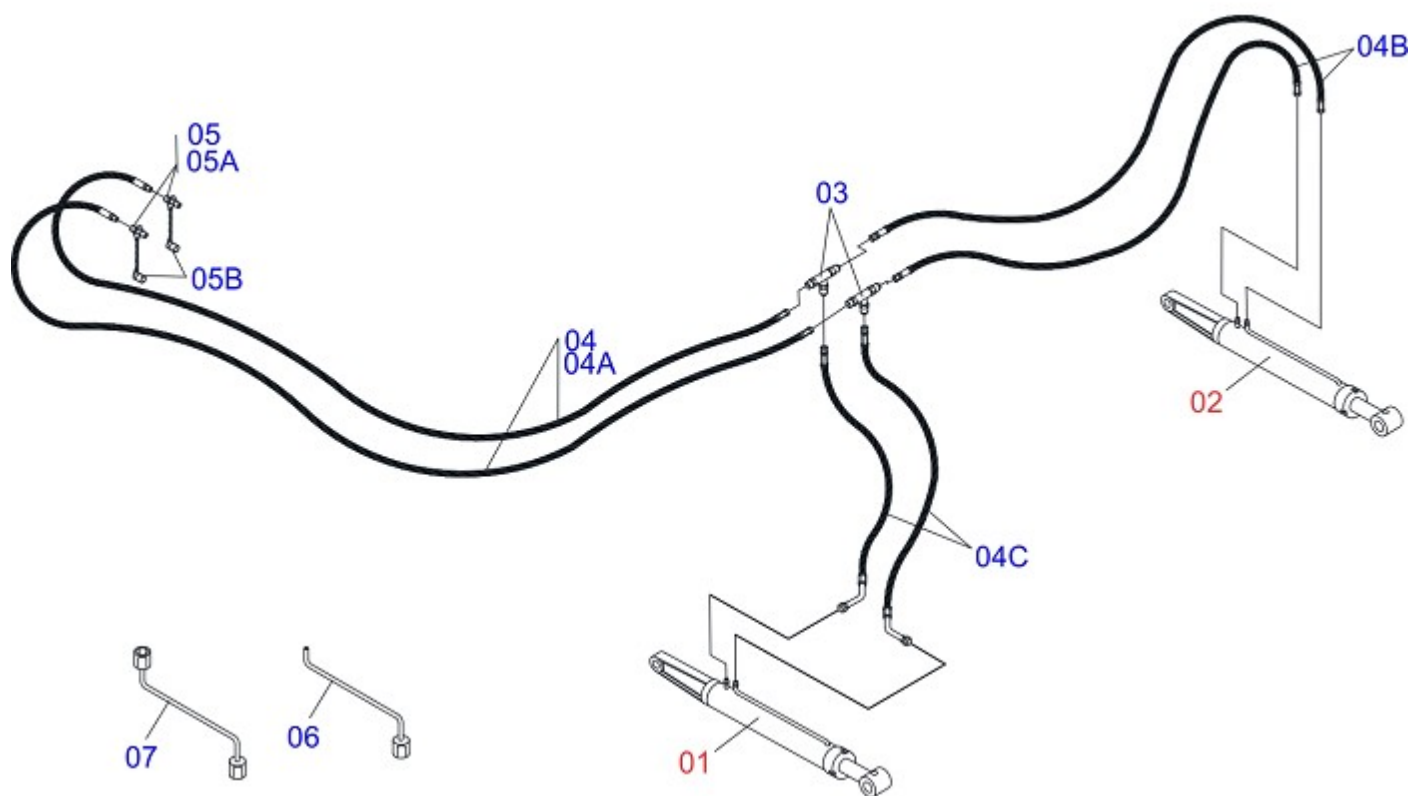

Artículo	Código	Descripción	QT
00	0909090758	CIRC.HIDR. MF 4292-4 BT S-0510	01
01	0501046992	CILINDRO HIDRAULICO 44,45 X 85,7 X1010 X 400 BBD	01
02	0501046993	CILINDRO HIDRAULICO 44,45 X 85,7 X1010 X 400 BBE	01
03	0503013493	CONEXION T MACHO	02
04	0501059946		01
04A	0501080076	MANGUERA 1/2 X 2500 TR-TM	02
04B	0501080014		02
04C	0501080267		02
05	0501053834	MACHO ENG RAP 1/2 NPT CON TAPA	02
05A	0503011627	MACHO ENGANCHE RAP AGR 1/2 NPT	02
05B	0503011882	TAPA PLASTICA P/ ENG RAP	02
06	0501061617	CLAVE 1 CABO PLANO	01
07	0501068213	CLAVE DOBLE 5/8 X 3/4	01

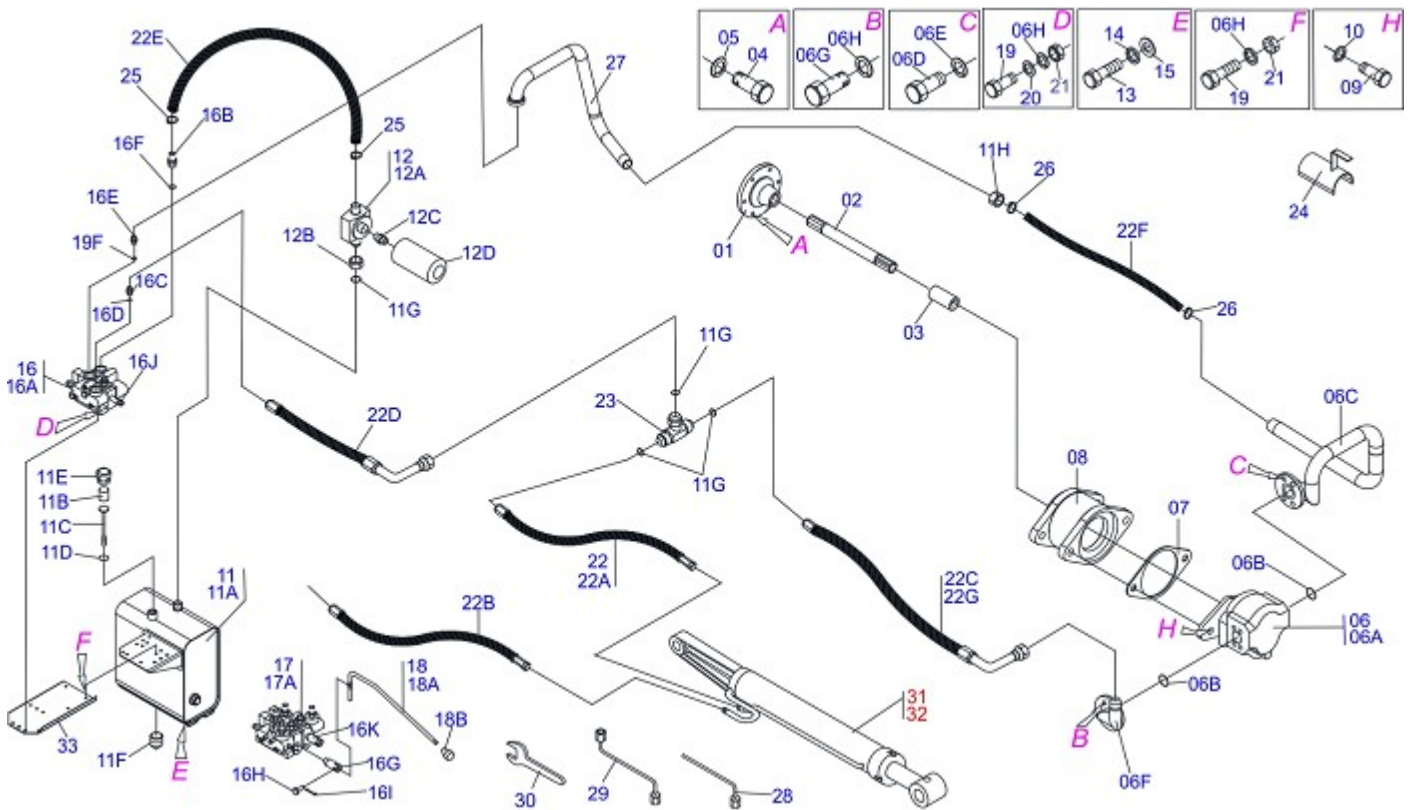

Artículo	Código	Descripción	ZF / CA
01	0501067327	BRIDA ACOPLAMIENTO	01 01
02	0503030838	BUJE 1.1/8" X 61 ESTR	00 01
02.	0501059981		01 00
03	0503030838	BUJE 1.1/8" X 61 ESTR	01 01
04	0503011313	TORNILLO M8 X 1,25 X 50	06 06
05	0503010180	ARANDELA PRESION 7/16"	06 06
06	0501059935		01 01
06A	0503061770	BOMBA B31	01 01
06B	0503010173	ANILLO O'RING 2-220 N 3006-9B	02 02
06C	0521061552		01 01
06D	0503010355	TORNILLO 7/16" UNC X 1"	04 04
06E	0503011446		04 04
06F	0501069661	DUCTO PRESION BOMBA	01 01
06G	0503010134	TORNILLO 3/8" UNC X 1"	04 04
06H	0503010025		10 10
07	0561016191		01 01
08	0511069926		01 01
09	0503010752		02 02
10	0503010019		02 02
11	0501047575	RESERVOIR OLEO COMPLETO	01 01
11A	0501068685	RESERVOIR OLEO	01 01
11B	0503030044	ELEM FILTRANTE AR	01 01
11C	0501060975	MEDIDOR ACEITE	01 01
11D	0503010185	ANILLO O'RING 2-221 N 3006-9B	01 01
11E	0502020472	CUERPO TAPA TANQUE	01 01
11F	0503031604	TAPON 1/2 BSP	01 01
11G	0503010046	ANILLO O'RING 2-216 N 3006-9B	05 05
11H	0501016309	TUERCA 2" UNC 16FPP X 2.5/16"	01 01
12	0501041108	FILTRO RETORNO MAYOR COMPL	01 01
12A	0502050002	CABCT FILTRO RETORNO	01 01
12B	0501010594	TUERCA 1" BSP S 1.5/8"	01 01
12C	0501010595	NIPLE 1 NF SEXT.1.1/8 X 37	01 01
12D	0503010183	FILTRO RETORNO	01 01



Artículo	Código	Descripción	ZF / CA
13	0501010161	TORNILLO 1/2" UNC X 1.1/4"	04 04
14	0503010019		04 04
15	0511017302		04 04
16	0501040871	COMANDO 1/2" COMPLETO	01 01
16A	0503060080	COMANDO 1/2"	01 01
16B	0501010591	BICO P/MANGUERA	01 01
16C	0501010589	NIPLE 1.1/16UN	01 01
16D	0503011109	ANILLO O'RING 2-119 N 3006-9B	02 02
16E	0501010590	NIPLE 7/8 NF HEX 1 X 48	02 02
16F	0503010045	ANILLO O'RING 2-116 N 3006-9B	02 02
16G	0503030347	FIJADOR SUP PALANCA (SAUER DANFOSS)	01 01
16H	0521010533	EJE UNION 7,85 X 25	01 01
16I	0503010140		01 01
16J	0503030387	PLUG	02 02
16K	0503030388	PLUG	01 01
17	0501059952		01 01
17A	0503060016	COMANDO DOBLE 1/2"	01 01
18	0501048023	ACCIONADOR MANDO	02 02
18A	0511060695	ACCIONADOR MANDO	02 02
18B	0503030878	MANOPLA PALANCA	02 02
19	0501010080	TORNILLO 3/8" UNC X 1.1/2"	06 06
20	0501010984	ARANDELA PLANA	06 06
21	0503010026	TUERCA 3/8"	06 06
22	0501059945		01 01
22A	0501081384		02 02
22B	0501080022	MANGUERA 1/2 X 1100 TR-TR	02 02
22C	0501080062		02 02
22D	0501081077	MANG 3/4" X 3100 TC-TC	01 01
22E	0501010610	MANGUERA 1" X 800 AB-AB	01 01
22F	0551012897		01 01
22G	0501080825	MANGUERA 1/2" X 1100 TR-TC	02 02
23	0503013493	CONEXION T MACHO	02 02
24	0511064563	PROTECTOR MANGUERA	01 01
25	0503010184	ABRAZADERA 1.1/4 A 1.1/2	02 02
26	0503010243	ABRAZADERA 1.1/2" A 2"	02 02
27	0521061677		01 01
28	0501061617	CLAVE 1 CABO PLANO	01 01
29	0501068213	CLAVE DOBLE 5/8 X 3/4	01 01
30	0511010153	CLAVE FIXA 2.5/16	01 01
31	0501046992	CILINDRO HIDRAULICO 44,45 X 85,7 X1010 X 400 BBD	01 01
32	0501046993	CILINDRO HIDRAULICO 44,45 X 85,7 X1010 X 400 BBE	01 01
33	0561016462		01 01

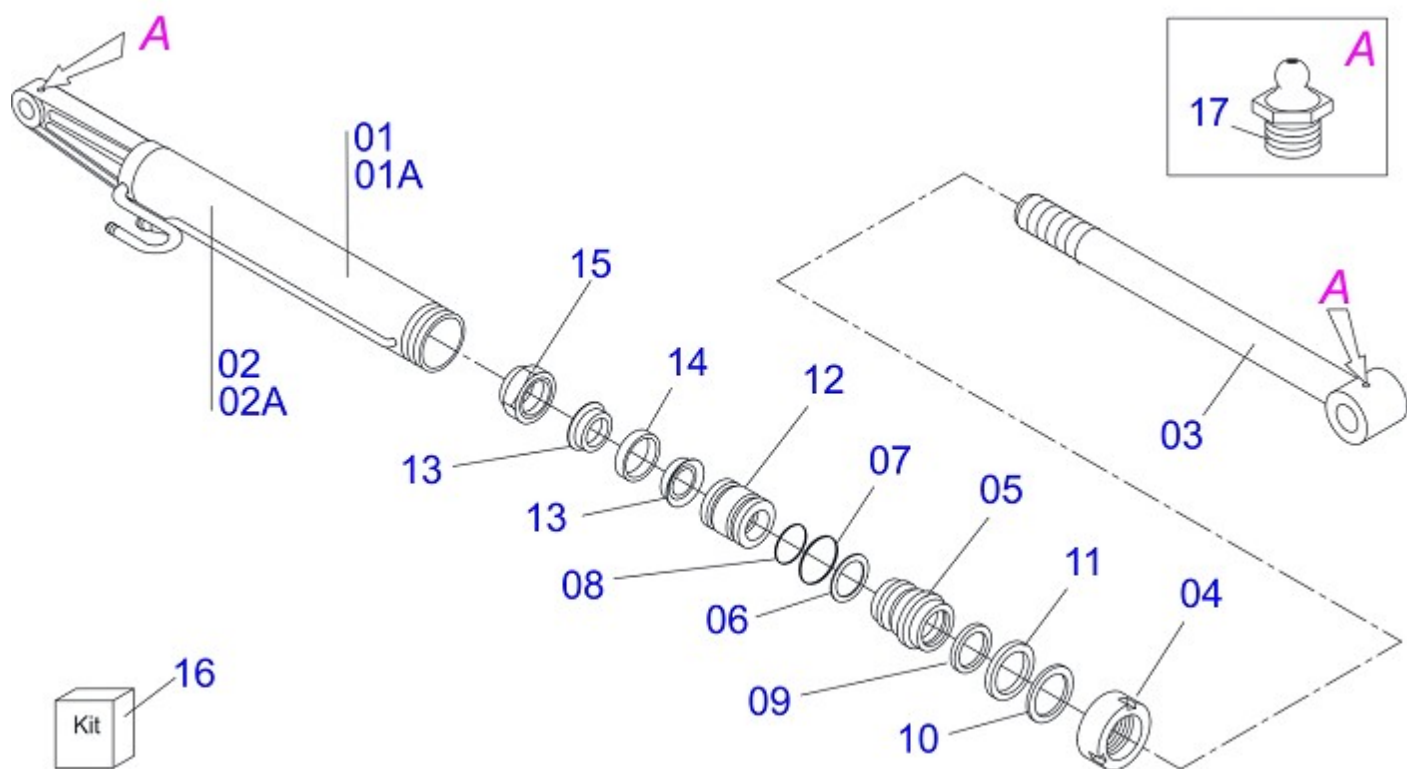

Artículo	Código	Descripción	QT
00	0909090760	CIL.HIDR.44,45X85,7X1010X400 DIR/ESQ.	01
01	0501046992	CILINDRO HIDRAULICO 44,45 X 85,7 X1010 X 400 BBD	01
01A	0501046993	CILINDRO HIDRAULICO 44,45 X 85,7 X1010 X 400 BBE	01
02	0501068207	CAMISA 85,72 X 855 ESQ PD MF 292-4	01
02A	0501068206	CAMISA 85,72 X 855 DIR PD MF 292-4	01
03	0501068208	EXTENSOR 44,45 X 670	01
04	0502010993	TAPA MOVIL 85,72	01
05	0502010781	SOPORTE ANILLOS 44,45 X 85,72	01
06	0503010761	ANILLO RASCADOR D-1750	01
07	0503010990	ANILLODE VEDACION	01
08	0503010949	ANILLO GUIA INTERNO W2-2000-500	01
09	0503011060	ANILLO BACK-UP 8-336	01
10	0503010979	ANILLODE VEDACION	01
11	0503010042	ANILLO O-RING 2-214 N 3006-9B	01
12	0502010843	EMBOLO 44,45 X 85,7	01
13	0503010170	ANILLODE VEDACION	02
14	0503010948	ANILLO GUIA EXTERNO W4-3346-590	01
15	0503010063	TUERCA 1" UNF	01
16	0503030387	PLUG	02
17	0503010002		02



MARCHESAN IMPLEMENTOS E MÁQUINAS AGRÍCOLAS TATU S.A.

AV. Marchesan, 1979 - Casilla de Correos, 131 - CEP 15994-900 - Matão - SP - Brasil

Fono: +55 16.3382-8282

(FAX Venta)+55 16.3382.8297 - (Exportar) + 55 16.3382.1003

e.mail: tatu@marchesan.com.br

Home Page: www.marchesan.com.br

Redaccion e Ilustracion = GASPARI
e.mail = jgaspari@marchesan.com.br

**PIEZAS ORIGINALES
TATU**

