

CHASER BIN

DCA MAX 12000 BT

Code: 0501091456
Series: S-0813
Revision: 00
Date Revision: JULHO/2023

PARTS CATALOGUE

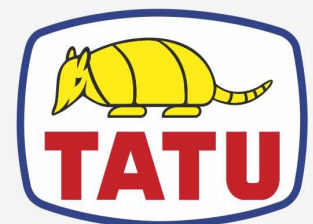

MARCHESAN



PRODUCTS

Code	Description	
0109090158	DCA MAXX 12000 BT	S-0813
0109090159	DCA MAXX 12000 BT S/PN	S-0813
0109090197	DCA MAXX 12000 ESPECIAL	S-0813

ATTENTION: IMPORTANT

Marchesan S.A. reserves the right to improve and/or modify the technical features of its products, without obligation to do the same with those products already sold and without prior knowledge of the dealer or the customer. The photos are only illustrative.



MARCHESAN

INDEX

0909091877	FRAME	1
0909091878	BUCKET	2
0521042342	ENDLESS REDUCER	3
0511057727	LADDER ASSY	4
0511053577	ASSY RUNNING MACHINE TRANSPORT	5
0521042348	ASSY DISTRIBUTOR	6
0531055343	1,4:1 CONICAL SHAFT MULTIPLIER BOX WITH MOTOR SUPPORT	7
0531055337	1,4:1 30 CONICAL SHAFT TRIPLE MULTIPLIER BOX	8
0511053582	SLUICE VALVE ASSY	9
0511054884	TRANSMISSION BOX	10
0511053583	SET FLOW DIVIDING	11
0511053584	SET FLOW DIVIDING MAT	12
0511053586	SET FIXER COVER REAR	13
0511053589	DISC FERTILIZER RIGHT ASSY	14
0511053590	DISC FERTILIZER LEFT ASSY	15
0511053503	DISC DISTRIBUTOR LIMESTONE RIGHT ASSY	16
0511053504	DISC DISTRIBUTOR LIMESTONE LEFT ASSY	17
0511053572	RIGHT WHEEL ASSY	18
0909091875	CALIBRATION KIT	19
0511056596	SET PLUVIOMETER	20
0511053812	SYSTEM HYDRAULIC	21
0511055729	FIELD-IQ TRIMB CONTROL CABIN ASSY	22
0511058686	CONDUITE SET APT TRIMBLE	23
0511054663	PARTS APT TRIMBLE	24

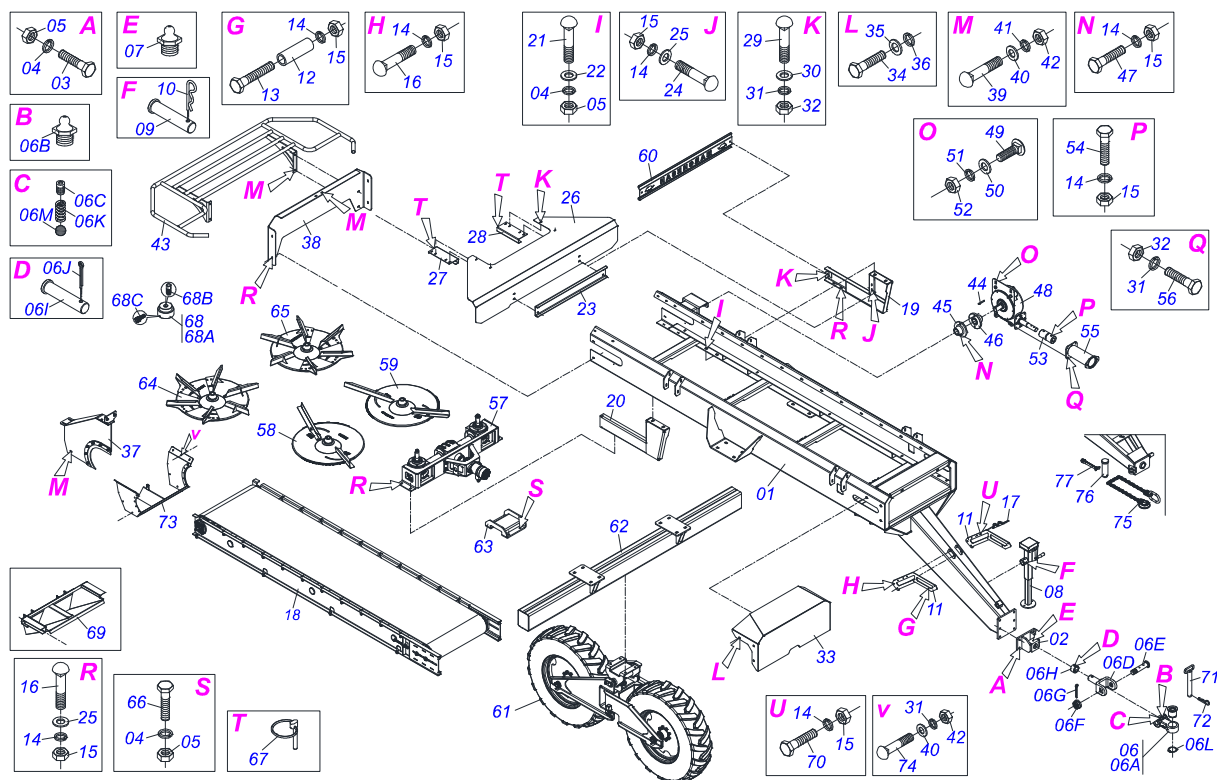

Item	Code	Description	See page	QT
01	0521064722	FRAME DCA MAXX 12000		01
02	0521062543	HITCH SUPPORT		01
03	0501010125	3/4" X 2-1/2" BOLT		04
04	0503010023	3/4" SPRING WASHER		16
05	0503010014	3/4" HEX NUT		16
06	0511054601	HITCH ARTICULATED TRACTOR		01
06A	0501110778	TRACTOR HITCH		01
06B	0503010002	1800 GREASE FITTING		01
06C	0503016482	BOLT		02
06D	0502040846	U TRACTOR HITCH		01
06E	0571012612	PIVOT SHAFT		01
06F	0501011301	1.1/2 UNC 6FPP 2.5/16 NUT		01
06G	0503010010	1/4" X 2.1/2" COTTERPIN		01
06H	0521010681	BUSHING COUPLING BODY		01
06I	0521010639	COUPLING SHAFT		01
06J	0503010571	1/4" X 1.1/2 COTTERPIN		01
06K	0503033731	LEFT COMPRESSION SPRING		02
06L	0503010396	501060 CLAMPING RING (FOR AXLE)		01
06M	0503011331	3/8 BALL		02
07	0503010002	1800 GREASE FITTING		01
08	0511041259	DRAWBAR JACK ASSY		01
09	0521010549	COUPLING SHAFT		01
10	0503030168	HITCH PIN CLIP		01
11	0571014202	BODY SUPPORT HOSE		02
12	0571014203	SLEEVE \varnothing 13,50 X \varnothing 19 X 105 DCA		04
13	0503011124	3/8" X 5" BOLT		04
14	0503010025	3/8 SPRING WASHER		25
15	0503010026	3/8" NUT		25
16	0501011643	3/8 X 1" BOLT		12
17	0541011767	HOSE FIXATION		01
18	0511053577	ASSY RUNNING MACHINE TRANSPORT	5	01



Item	Code	Description	See page	QT
19	0521064163	SUPPORT LEFT DISTRIBUTOR		01
20	0521064164	SUPPORT RIGHT DISTRIBUTOR		01
21	0503013438	3/4 UNC X 1.3/4 C A P Q G.2 BOLT		04
22	0501017065	FLAT WASHER		04
23	0571017693	LOCK SUPPORT DISTRIBUTOR		01
24	0501010942	3/8" X 1-1/4" BOLT		04
25	0501013518	FLAT WASHER		12
26	0571017694	BAMPER (INOX)		01
27	0521065577	SUPPORT RIGHT		01
28	0521065578	SUPPORT LEFT		01
29	0503011952	5/16" X 3/4" BOLT		06
30	0501010694	FLAT WASHER		06
31	0503010179	LOCK WASHER 5/16 ZN 1K01528		10
32	0503010337	5/16" NUT		10
33	0521064191	COVER FRONT FRAME		01
34	0503010834	1/2 X 1 BOLT		06
35	0501013519	FLAT WASHER		06
36	0503010019	1/2" SPRING WASHER		06
37	0511053584	SET FLOW DIVIDING MAT	12	01
38	0571014193	COVER REAR FRAME		01
39	0503011953	5/16" X 1" BOLT		07
40	0501010694	FLAT WASHER		07
41	0503010179	LOCK WASHER 5/16 ZN 1K01528		07
42	0503010337	5/16" NUT		07
43	0521064170	PROTECTION DISC		01
44	0501010540	KEYWAY SQUARE		02
45	0511016540	MAT COUPLING FLANGE		01
46	0511016541	REDUCTION COUPLING FLANGE		01
47	0503010849	3/8" X 1-1/2" BOLT		02
48	0521042342	ENDLESS REDUCER	3	01
49	0503012407	5/8" X 1-1/2" BOLT		02
50	0501012140	FLAT WASHER		02
51	0503010027	5/8 SPRING WASHER		02
52	0503010013	5/8 NUT		02
53	0521064187	COUPLING REDUCTOR		01
54	0503011268	3/8" X 2-1/2" BOLT		01
55	0521064186	SUPPORT HIDRAULIC MOTOR		01
56	0503010371	5/16" X 1" BOLT		04
57	0521042348	ASSY DISTRIBUTOR	6	01
58	0511053589	DISC FERTILIZER RIGHT ASSY	14	01
59	0511053590	DISC FERTILIZER LEFT ASSY	15	01
60	0571014197	COVER REAR		01
61	0511053572	RIGHT WHEEL ASSY	18	02
62	0521064153	CARRYING-WHEELS SUPPORT		01
62.	0521066737	CARRYING-WHEELS SUPPORT		01
63	0521064155	SUPPORT FIXER ARTICULATION CARRYING-WHEELS		02
64	0511053503	DISC DISTRIBUTOR LIMESTONE RIGHT ASSY	16	01
65	0511053504	DISC DISTRIBUTOR LIMESTONE LEFT ASSY	17	01
66	0503011198	C3/4" X 6" SCREW		08
67	0503030119	LOCK PIN		02
68	0521045169	SACADOR DISC DISTRIBUTOR		01
68A	0571017679	SLEEVE SACADOR DISC DISTRIBUTOR		01
68B	0571017678	BOLT SACADOR		01
68C	0503011148	3/8" X 1/2" BOLT		02
69	0521065576	COLLECCION		01
70	0503010751	C3/8" X 1.1/4" HEX BOLT G.5		02
71	0501069080	COUPLING SHAFT		01
72	0503031035	HITCH PIN CLIP		01



DCA MAX 12000 BT
FRAME

Page 1
0909091877

Item	Code	Description	See page	QT
73	0511053583	SET FLOW DIVIDING	11	01
74	0503011762	SCREW 5/16UNC X 1.1/4 CAPQ G.2 ZN		06
75	0503013150	1300 X 3/8 CHAIN		01
76	0581011220	COUPLING SHAFT		01
77	0503010131	3/16" X 1-1/2" COTTERPIN		01

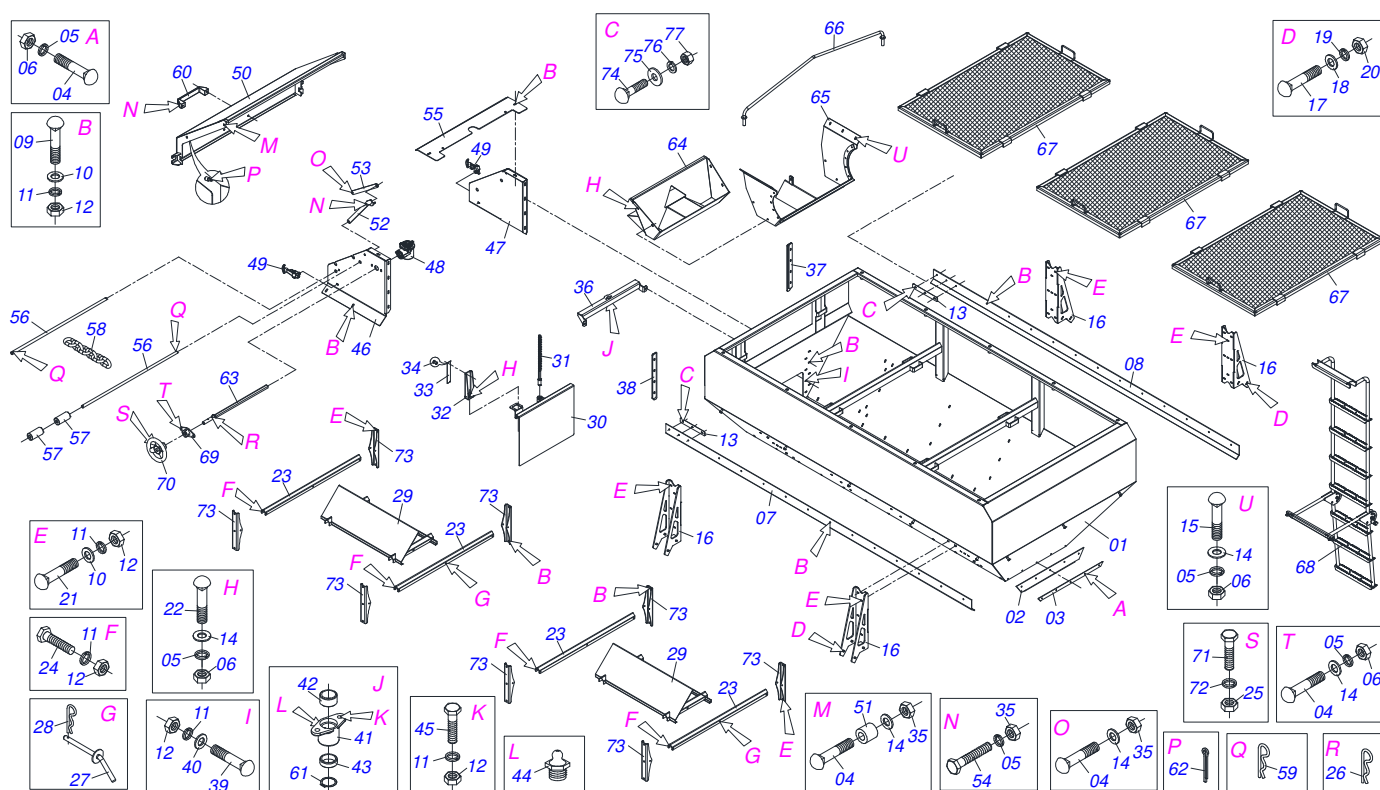

Item	Code	Description	See page	QT
01	0521064146	BUCKET INOX 6M³ DCA		01
02	0503033819	ANGLE BAR SEALING FRONT		01
03	0571014206	FIXER RUBBER SEALING FRONT		01
04	0503011953	5/16" X 1" BOLT		10
05	0503010179	LOCK WASHER 5/16 ZN 1K01528		21
06	0503010337	5/16" NUT		18
07	0503033820	ANGLE BAR SEALING RIGHT		01
08	0503033821	ANGLE BAR SEALING LEFT		01
09	0501011643	3/8 X 1" BOLT		38
10	0501013518	FLAT WASHER		86
11	0503010025	3/8 SPRING WASHER		104
12	0503010026	3/8" NUT		104
13	0571014204	FIXER ANGLE BAR SIDE		02
14	0501010694	FLAT WASHER		16
15	0503011762	SCREW 5/16UNC X 1.1/4 CAPQ G.2 ZN		06
16	0521064167	REINFORCING BUCKET		04
17	0503014378	1/2" X 1-1/2" BOLT		16
18	0501013519	FLAT WASHER		16
19	0503010019	1/2" SPRING WASHER		16
20	0503010060	1/2 UNC G.5 ZN HEX NUT		16
21	0501010942	3/8" X 1-1/4" BOLT		24
22	0503011952	5/16" X 3/4" BOLT		05
23	0571014201	BODY SUPPORT DEFLECTOR		04
24	0503010765	3/8" X 3" BOLT		08
25	0503010144	1/4" NUT		01
26	0503030012	HITCH PIN CLIP		01
27	0501068994	8,30 X 78 LOCK PIN		04
28	0503030168	HITCH PIN CLIP		04
29	0521064197	DEFLECTOR		02
30	0511053582	SLUICE VALVE ASSY	9	01
31	0521064184	SPINDLE SLUICE VALVE		01



Item	Code	Description	See page	QT
32	0571014290	SUPPORT SCALE		01
33	0503030751	REGULATOR PLATE		01
34	0503010001	3.2 X 5.5 RIVET		04
35	0503013759	NUT		06
36	0521064182	SUPPORT BEARING REGULACION		01
37	0521064180	GUIDE LEFT SLUICE VALVE		01
38	0521064181	GUIDE RIGHT SLUICE VALVE		01
39	0501010942	3/8" X 1-1/4" BOLT		08
40	0501013518	FLAT WASHER		08
41	0502010581	ROD BEARING		01
42	0521010457	SLEEVE		01
43	0521010458	SLEEVE		01
44	0503010002	1800 GREASE FITTING		01
45	0503010371	5/16" X 1" BOLT		02
46	0521064176	COVER SIDE RIGHT		01
47	0521064177	COVER SIDE LEFT		01
48	0511054884	TRANSMISSION BOX	10	01
49	0511053586	SET FIXER COVER REAR	13	02
50	0521064179	COVER REAR		01
51	0561011952	10 X 13 X 16 SLEEVE		02
52	0571014209	BAR LOWER ARTICULATION COVER REAR		01
53	0571014210	BAR SMALLER ARTICULATION COVER REAR		01
54	0503010363	BOLT 5/16 UNC X 1 C S G.2 ZN		01
55	0571014192	LOCK SIDE SLUICE VALVE		01
56	0571014190	AXLE 19,05 X 900		02
57	0571014191	SLEEVE 20,50 X 50,80 X 104		07
58	0503016743	CHAIN 3/4" X 6 LINK		06
59	0503030285	HITCH PIN CLIP		04
60	0503011957	NYLON HANDLE		01
61	0503010406	501025 CLAMPING RING (FOR AXLE)		01
62	0503010140	1/8" X 3/4" COTTERPIN		01
63	0521064185	AXLE HANDLE SLUICE VALVE		01
64	0521064175	FLOW DIVIDING		01
65	0511053583	SET FLOW DIVIDING	11	01
66	0521064169	BRACKET DITRIBUTOR		05
67	0521064168	SCREEN		03
68	0511057727	LADDER ASSY	4	01
69	0521064183	BEARING AXLE LEVER		01
70	0561010179	SEED REGULACION HANDLE		01
71	0503010373	SCREW 1/4 UNC X 2 CS G.2 ZN		01
72	0503010143	1/4" SPRING WASHER		01
73	0571014200	FIXER SUPPORT DEFLECTOR		08
74	0503011762	SCREW 5/16UNC X 1.1/4 CAPQ G.2 ZN		06
75	0501010694	FLAT WASHER		06
76	0503010179	LOCK WASHER 5/16 ZN 1K01528		06
77	0503010337	5/16" NUT		06

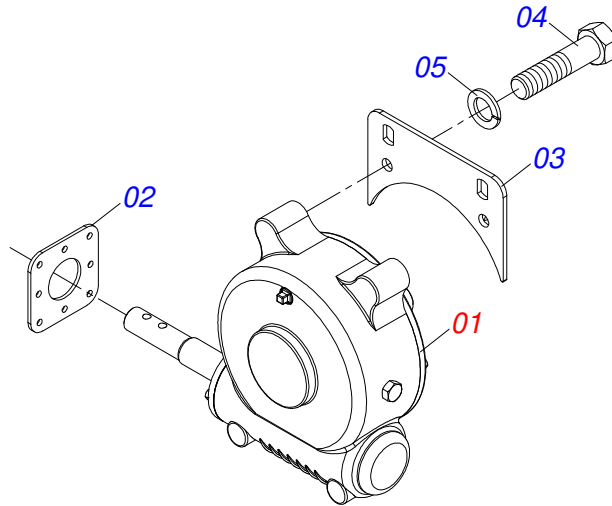

Item	Code	Description	See page	QT
01	0501047985	REDUCER		01
02	0571014238	FLANGE REDUCTION		01
03	0571014194	SUPPORT REDUCTION		01
04	0503011167	M16 X 2 X 30 BOLT		02
05	0503010027	5/8 SPRING WASHER		02

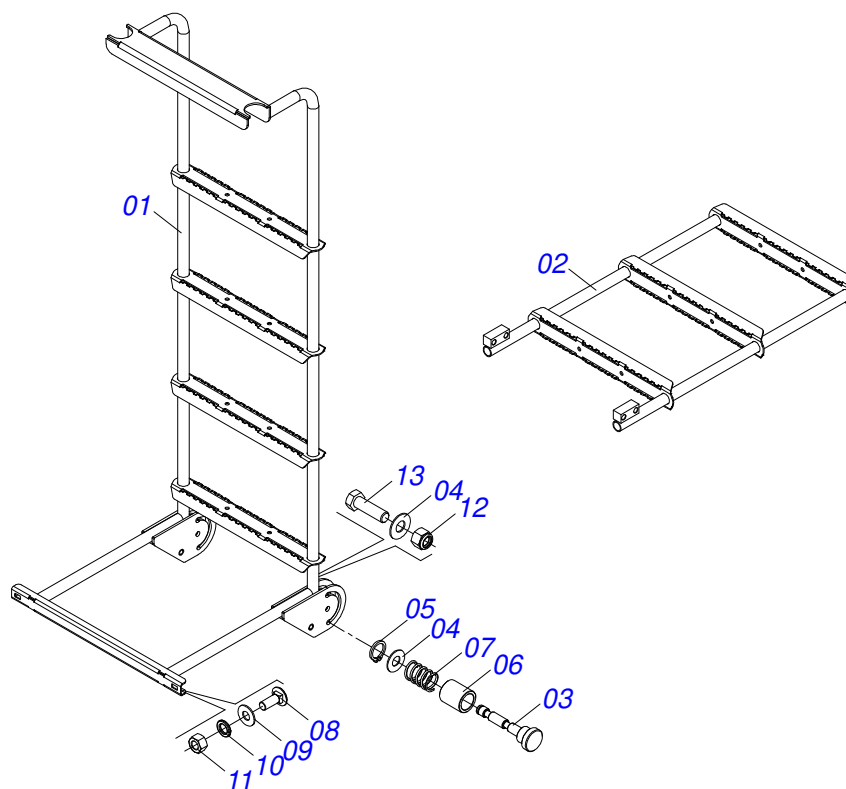

Item	Code	Description	See page	QT
01	0521066335	LADDER		01
02	0521066336	EXTENSION		01
03	0571019930	EXTENSION LOCK AXLE		01
04	0501013519	FLAT WASHER		03
05	0503010291	501012 CLAMPING RING (FOR AXLE)		01
06	0571019931	GUIDE GLOVE		01
07	0503032035	0.7" X 1.2" X 1" COMPRESSION SPRING		01
08	0501011643	3/8 X 1" BOLT		02
09	0501013518	FLAT WASHER		02
10	0503010025	3/8 SPRING WASHER		02
11	0503010026	3/8" NUT		02
12	0503010589	1/2" UNC SELF ADJUSTING NUT		02
13	0503010734	1/2" X 2-1/2" BOLT		02

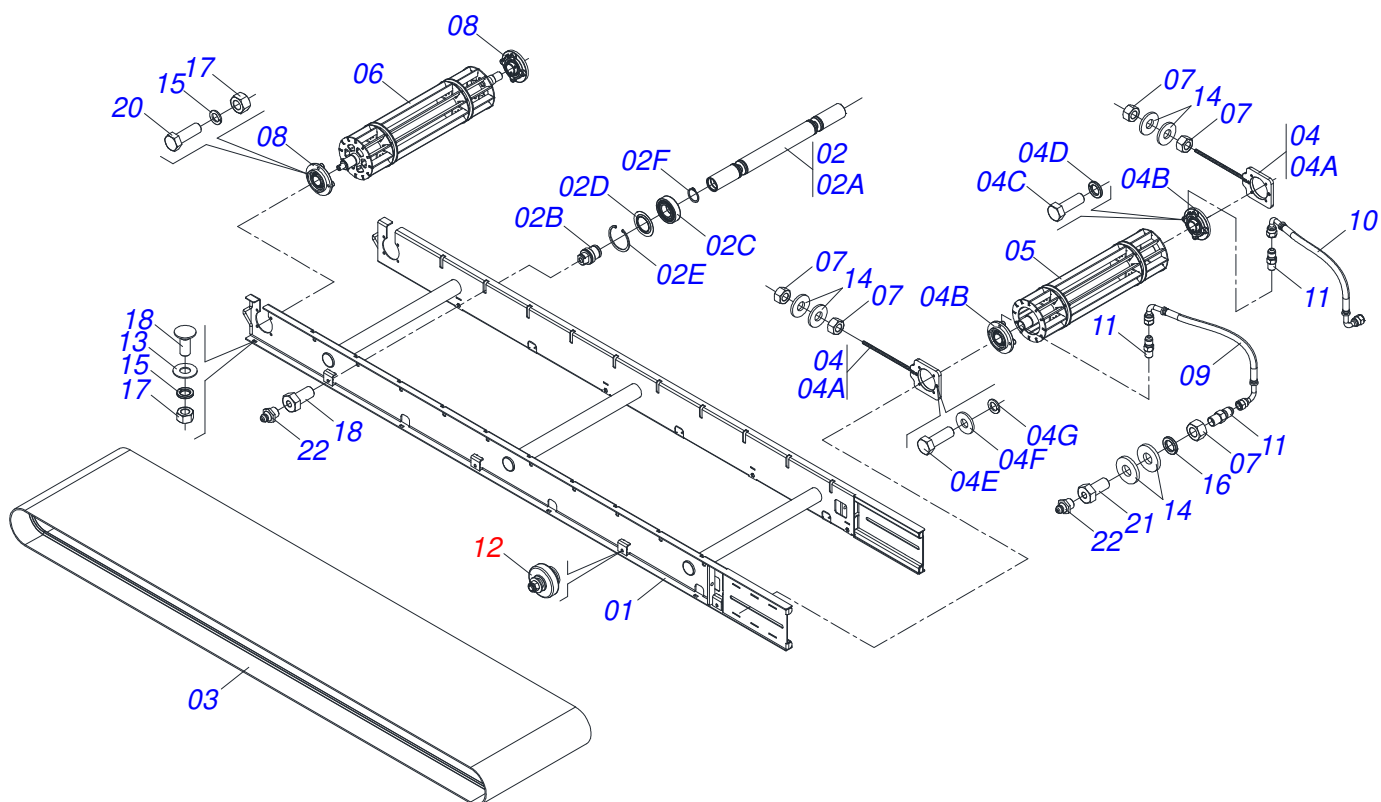

Item	Code	Description	See page	QT
01	0521064148	SUPPORT MAT	01	01
02	0511053576	ROLL LOAD SUPPORT ASSY	10	10
02A	0521064152	ROLL LOAD SUPPORT	01	01
02B	0571014234	AXLE ROLL LOAD SUPPORT	02	02
02C	0513010786	6206 RS1 BEARING	02	02
02D	0503016508	RING MILOS 6206 JV	02	02
02E	0503011800	SEAL RING	02	02
02F	0503010707	501030 CLAMPING RING (FOR AXLE)	02	02
03	0503033742	MAT RUBBER TWO GUIDES	01	01
04	0511053575	TENSIONER MAT ASSY	02	02
04A	0521064149	TENSIONER MAT	01	01
04B	0503062591	BEARING ASSY TENSOR	01	01
04C	0503011195	7/16" X 1.3/4" BOLT	04	04
04D	0503010180	7/16" SPRING WASHER	04	04
04E	0501010108	5/8" X 1" BOLT	02	02
04F	0501010453	FLAT WASHER	02	02
04G	0503010027	5/8 SPRING WASHER	02	02
05	0521064150	ROLL TIGHTENER	01	01
06	0521064151	ROLL ARRASTRE	01	01
07	0503010013	5/8 NUT	06	06
08	0503062591	BEARING ASSY TENSOR	02	02
09	0501082059	HOSE 1/4 X 300 TC-TC 90G	01	01
10	0501082060	HOSE 1/4 X 300 TC-TC 90G	01	01
11	0503012776	1/8" NF NIPPLE	04	04
12	0531055843	COMPLETE PULLEY	08	08
13	0501013519	FLAT WASHER	08	08
14	0501012140	FLAT WASHER	08	08
15	0503010019	1/2" SPRING WASHER	16	16
16	0503010027	5/8 SPRING WASHER	02	02
17	0503010060	1/2 UNC G.5 ZN HEX NUT	16	16
18	0501215078	R.1/2 UNC 1 BOLT WITH HOLE FOR GREASE NIPPLE	02	02



DCA MAX 12000 BT
ASSY RUNNING MACHINE TRANSPORT

Page 5
0511053577

Item	Code	Description	See page	QT
19	0503014734	BOLT		08
20	0501010077	1/2" X 2" BOLT		08
21	0581011495	SCREW 5/8 UNC X 1.1/4		02
22	0503010002	1800 GREASE FITTING		06

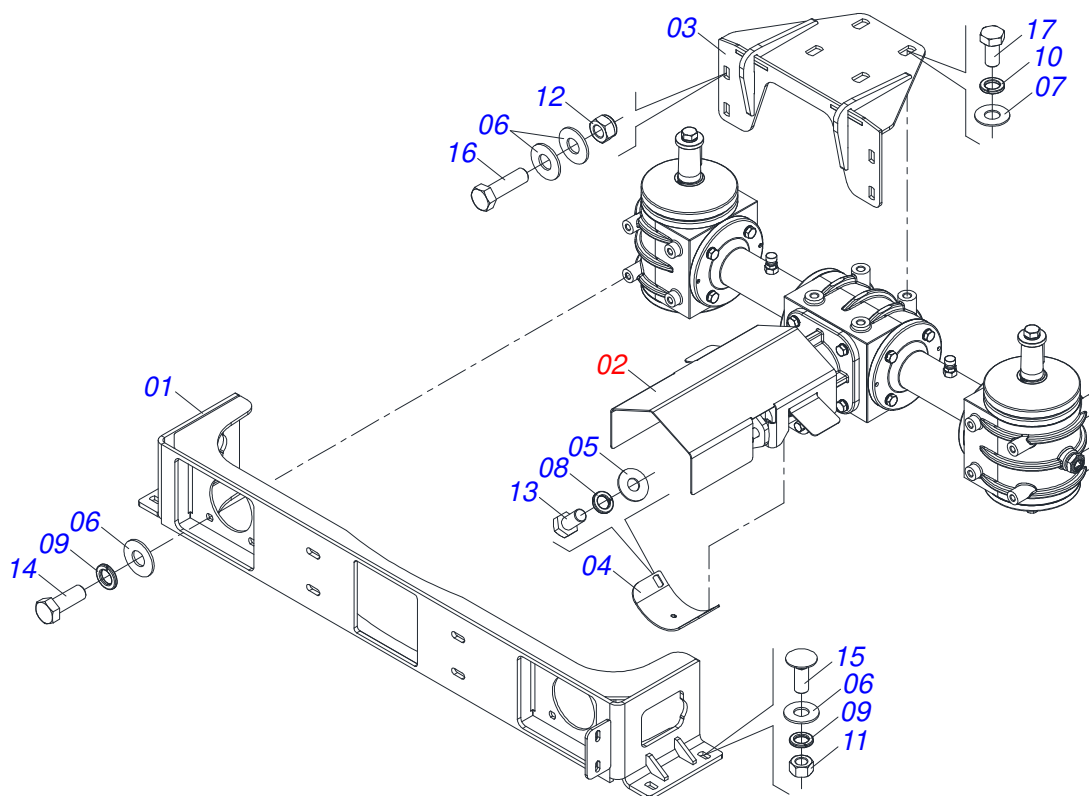

Item	Code	Description	See page	QT
01	0521064189	SUPPORT BOX TRANSMISSION		01
02	0531055343	1,4:1 CONICAL SHAFT MULTIPLIER BOX WITH 7 MOTOR SUPPORT		01
03	0531066477	BOX CENTRAL SUPPORT		01
04	0501310938	LOWER COVER SUPPORT		01
05	0503010357	8 X 20 X 1 FLAT WASHER		02
06	0501013518	FLAT WASHER		20
07	0501013519	FLAT WASHER		04
08	0503010179	LOCK WASHER 5/16 ZN 1K01528		02
09	0503010025	3/8 SPRING WASHER		12
10	0503010019	1/2" SPRING WASHER		04
11	0503010026	3/8" NUT		04
12	0503013357	3/8 SELF-ADJUSTING NUT		04
13	0503010295	SCREW 5/16 UNC X 5/8 CS G.2 ZN		02
14	0503011087	3/8" X 1" BOLT		08
15	0501011643	3/8 X 1" BOLT		04
16	0503010751	C3/8" X 1.1/4" HEX BOLT G.5		04
17	0503014691	M12 X 1,75 X 25 BOLT		04

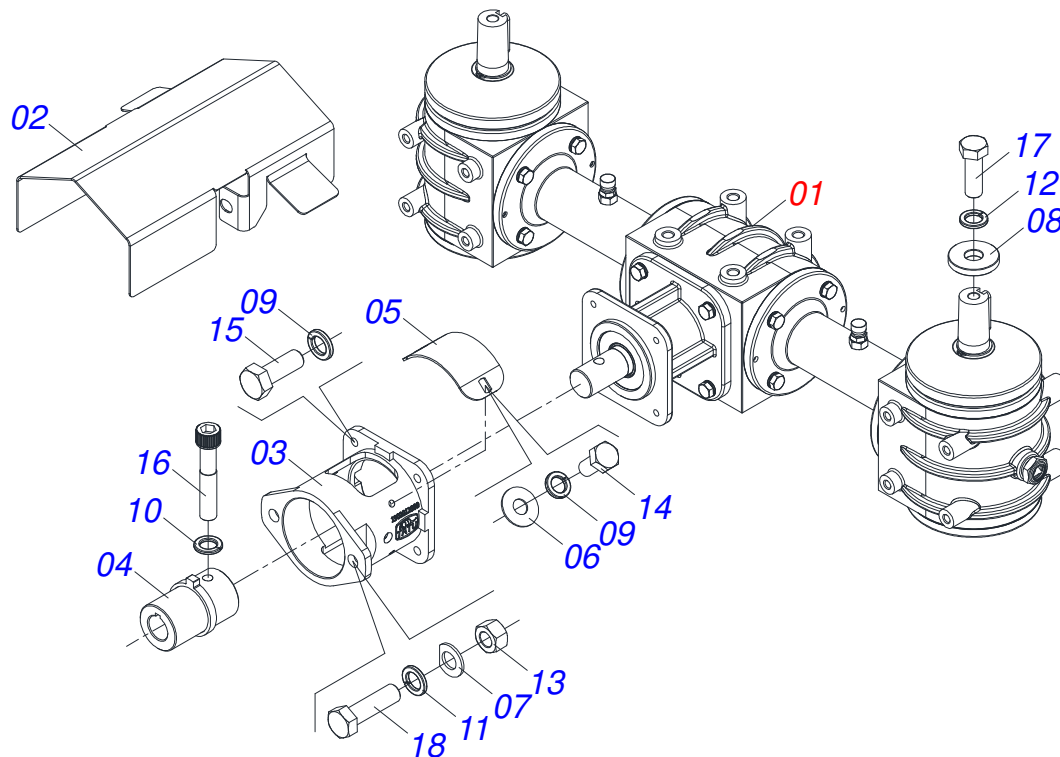

Item	Code	Description	See page	QT
01	0531055337	1,4:1 30 CONICAL SHAFT TRIPLE MULTIPLIER BOX	8	01
02	0501214379	HYDRAULIC MOTOR DEFLECTOR		01
03	0502012999	HYDRAULIC MOTOR SUPPORT		01
04	0531064304	COUPLING BUSHING WITH GEAR		01
05	0501214798	SUPPORT COVER		01
06	0503010357	8 X 20 X 1 FLAT WASHER		02
07	0501214404	13 X 24 X 2,00 FLAT WASHER		02
08	0571017696	WASHER 13,50 X 38 X 4,75		02
09	0503010179	LOCK WASHER 5/16 ZN 1K01528		06
10	0503010025	3/8 SPRING WASHER		01
11	0503010019	1/2" SPRING WASHER		02
12	0503012536	1/2" SPRING WASHER		02
13	0503010060	1/2 UNC G.5 ZN HEX NUT		02
14	0503010295	SCREW 5/16 UNC X 5/8 CS G.2 ZN		02
15	0503010358	5/16" X 5/8" BOLT		04
16	0503011094	3/8" X 2" BOLT		01
17	0503012808	1/2" X 1-1/2" BOLT		02
18	0503018701	SCREW 1/2 UNC X 1.3/4 CS G.5 ZN		02

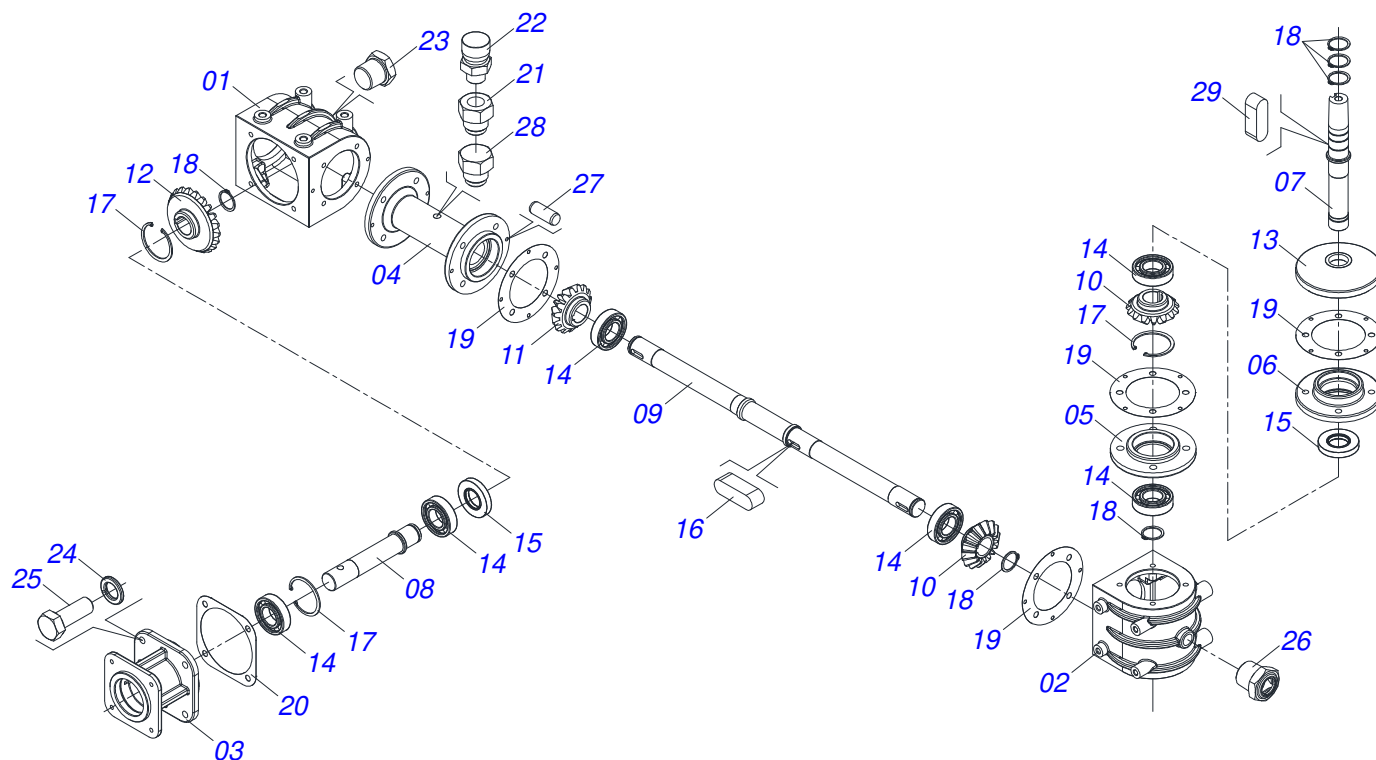

Item	Code	Description	See page	QT
01	0502013051	MULTIPLIER CENTRAL BOX		01
02	0502013052	MULTIPLIER SIDE BOX		02
03	0502013053	CENTRAL CUBE		01
04	0502013054	FLANGED SPOOLS		02
05	0502010357	LOWER COVER		02
06	0502010324	UPPER COVER		02
07	0571014239	AXLE DITRIBUTOR		02
08	0501214772	DRIVE AXLE MULTIPLICATOR BOX		01
09	0501214457	MULTIPLIER BOX AXLE		01
10	0503030153	15Z CONICAL GEAR		04
11	0503035809	BEVEL GEAR		01
12	0503035810	BEVEL GEAR		01
13	0581018645	RETENTION PROTECTOR		02
14	0503013427	BEARING 6206		10
15	0503010083	50791MBL SEAL		03
16	0503031030	5/16" X 1.98" KEYWAY		06
17	0503011800	SEAL RING		04
18	0503010707	501030 CLAMPING RING (FOR AXLE)		11
19	0503030157	5.12" X 3.21" X 0.008" JOINT		08
20	0503035818	127 X 110,5 X 0,20 JOINT BEARIN		01
21	0511016550	0.87" BREATHING HOLE		02
22	0503010325	VCA-118 VALVE		02
23	0503031604	1/2" BSP PLUG		03
24	0503011443	3/8" SPRING WASHER		36
25	0503010237	3/8" X 1" BOLT		36
26	0513010009	LEVEL DISPLAY		03
27	0513010725	PARALLEL GUIDE PIN 6 X 16 WITH INTERNAL THREAD		08
28	0501214378	RUBBER STOPPER		02
29	0501010536	KEYWAY SQUARE		02

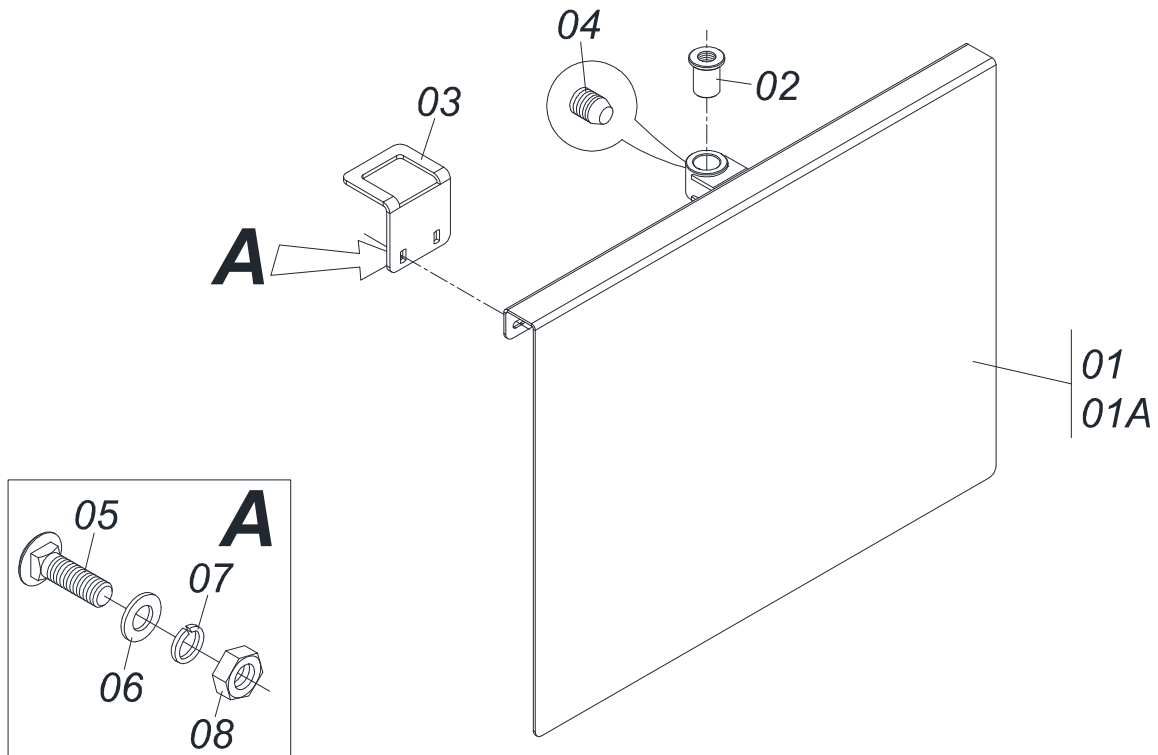

Item	Code	Description	See page	QT
01	0511053582	SLUICE VALVE ASSY	9	01
01A	0521064178	SLUICE VALVE		01
02	0501019831	ADJUSTING NUT		01
03	0571014211	ARROW SLUICE VALVE		01
04	0503011148	3/8" X 1/2" BOLT		01
05	0503011952	5/16" X 3/4" BOLT		02
06	0501010694	FLAT WASHER		02
07	0503010179	LOCK WASHER 5/16 ZN 1K01528		02
08	0503010337	5/16" NUT		02

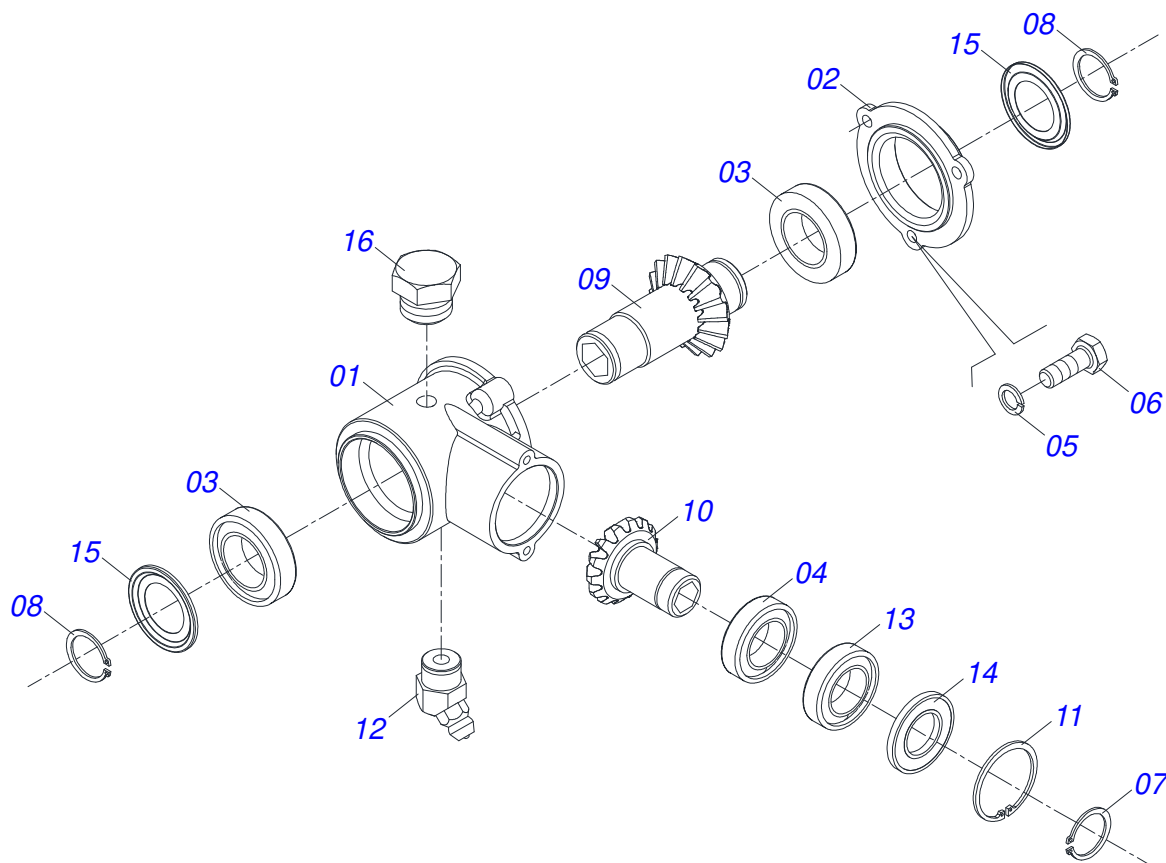

Item	Code	Description	See page	QT
01	0502012465	TRANSMISSION HUB		01
02	0502012464	HOPPER TRANSMISSION LID		01
03	0503016995	6006 BALL BEARING		02
04	0503015895	6005 Z BALL BEARING		01
05	0503010143	1/4" SPRING WASHER		03
06	0503011378	M6X1X16 C S 8.8 ZN BOLT		03
07	0503010406	501025 CLAMPING RING (FOR AXLE)		01
08	0503010707	501030 CLAMPING RING (FOR AXLE)		02
09	0502040856	CONICAL GEAR		01
10	0502040857	CONICAL GEAR		01
11	0503011105	SEAL RING		01
12	0503010003	1845 GREASE FITTING		01
13	0503011409	6005 Z BALL BEARING		01
14	0503017008	SEAL RING		01
15	0503017007	SEAL RING		02
16	0511017907	1/8" BSPT X 6 PLUG		01

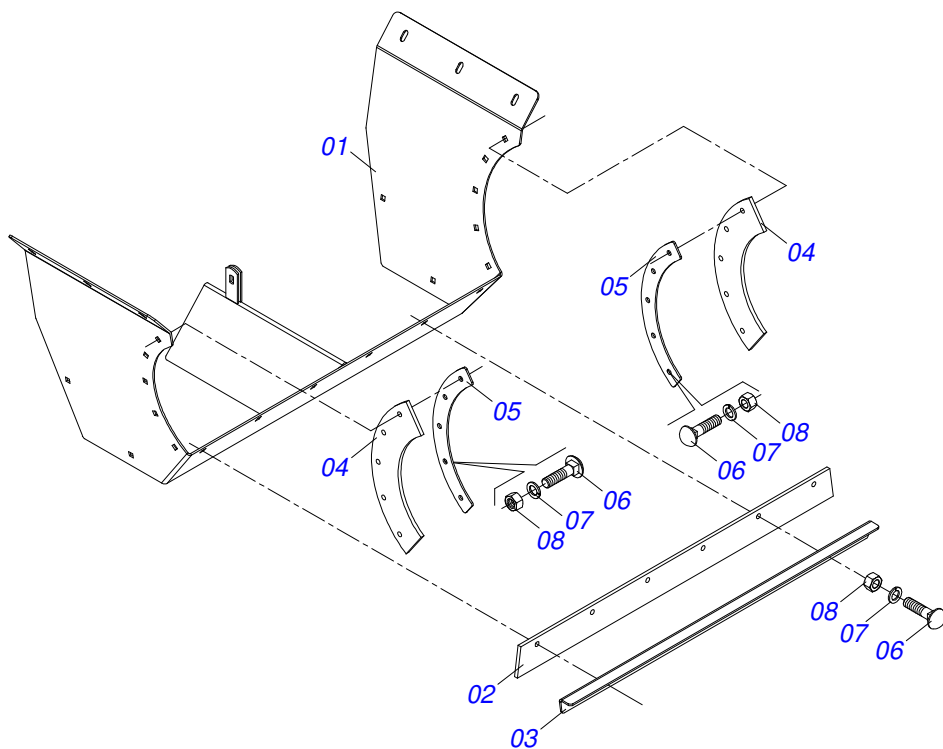

Item	Code	Description	See page	QT
01	0521064174	FLOW DIVIDER		01
02	0503033818	SCRAPER		01
03	0571014207	FIXER SCRAPER		01
04	0503033822	SCRAPER SIDE		02
05	0571014205	FIXER SCRAPER		02
06	0503011953	5/16" X 1" BOLT		16
07	0503010179	LOCK WASHER 5/16 ZN 1K01528		16
08	0503010337	5/16" NUT		16

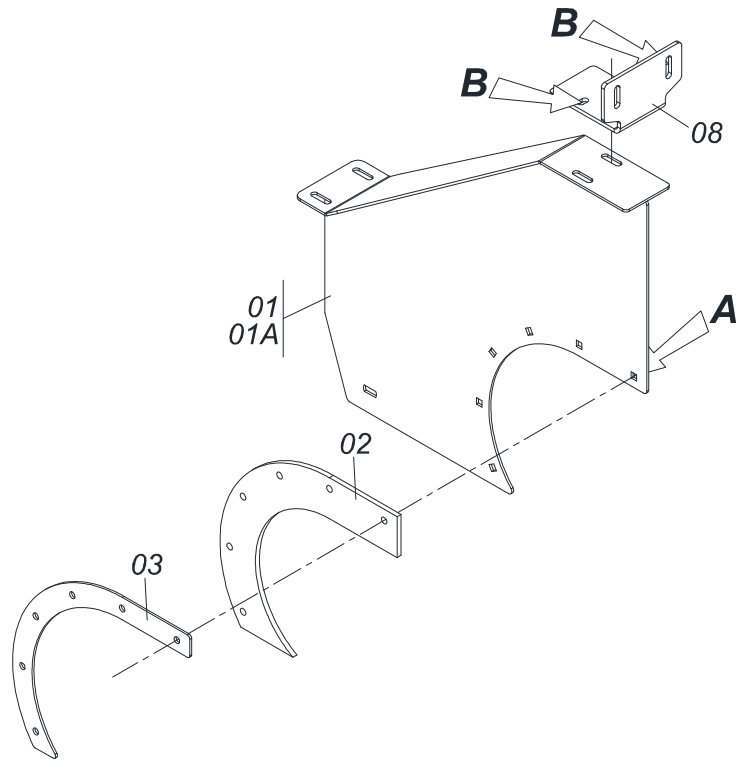
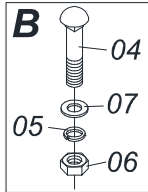
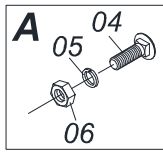

Item	Code	Description	See page	QT
01	0511053584	SET FLOW DIVIDING MAT	12	01
01A	0521064173	SUPPORT FLOW DIVIDING DCA		01
02	0503033823	FLOW DIVIDING		01
03	0571014208	FIXER RUBBER CENTRAL		01
04	0503011953	5/16" X 1" BOLT		10
05	0503010179	LOCK WASHER 5/16 ZN 1K01528		10
06	0503010337	5/16" NUT		10
07	0501010694	FLAT WASHER		04
08	0571017721	LOCK SUPPORT FLOW DIVIDING		01

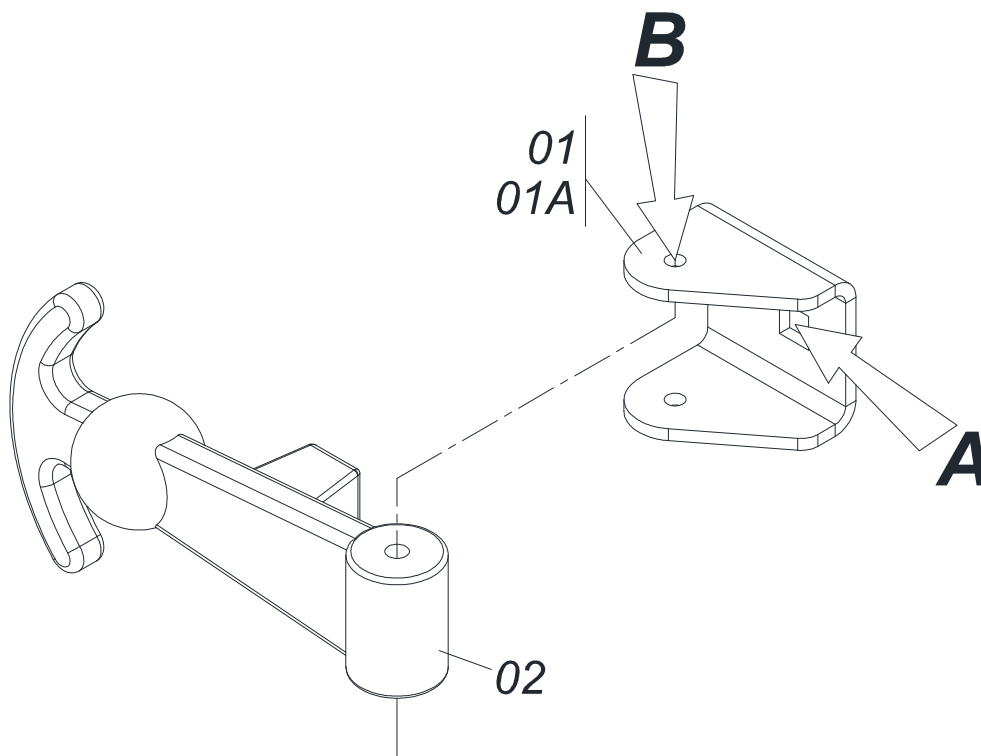
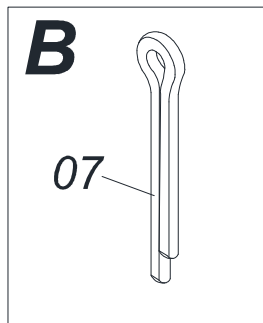
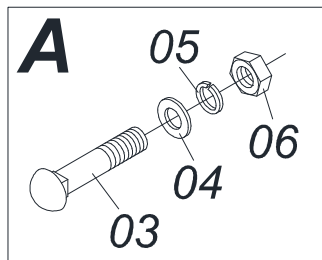

Item	Code	Description	See page	QT
01	0511053586	SET FIXER COVER REAR	13	01
01A	0571014198	SUPPORT FIXER CAP		01
02	0503011333	COVER FIXER		01
03	0503011952	5/16" X 3/4" BOLT		01
04	0501010694	FLAT WASHER		01
05	0503010179	LOCK WASHER 5/16 ZN 1K01528		01
06	0503010337	5/16" NUT		01
07	0503010274	5/32"X 2" COTTERPIN		01

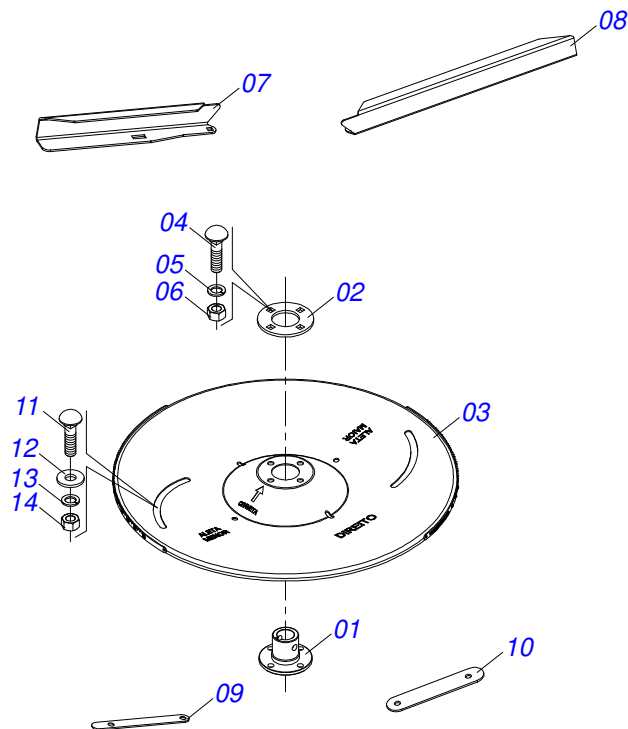

Item	Code	Description	See page	QT
01	0581010973	DISTRIBUTOR DISC SLEEVE		01
02	0571013670	DISTRIBUTOR DISC FLANGE		01
03	0521066690	DISC FERTILIZER RIGHT		01
04	0503012540	3/8" X 1" BOLT		04
05	0503012535	3/8" SPRING WASHER		04
06	0503012531	3/8" INOX NUT		04
07	0571017670	FLIP FERTILIZER RIGHT 295		01
08	0571017669	FLIP FERTILIZER RIGHT 385		01
09	0571017674	BAR LOWER FLIP LARGER		01
10	0571017673	BAR LOWER FLIP SMALLER		01
11	0503016881	5/16 UNC X 3/4 BOLT		04
12	0503012545	FLAT WASHER		04
13	0503012534	LOCK WASHER		04
14	0503012530	5/16" INOX NUT		04

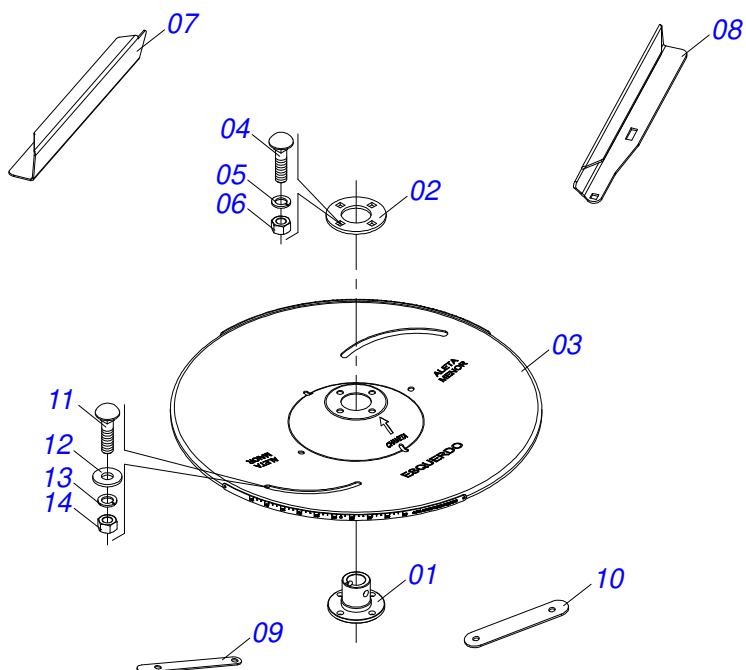

Item	Code	Description	See page	QT
01	0581010973	DISTRIBUTOR DISC SLEEVE		01
02	0571013670	DISTRIBUTOR DISC FLANGE		01
03	0521066691	DISC FERTILIZER		01
04	0503012540	3/8" X 1" BOLT		04
05	0503012535	3/8" SPRING WASHER		04
06	0503012531	3/8" INOX NUT		04
07	0571017672	FLIP FERTILIZER LEFT 295		01
08	0571017671	FLIP FERTILIZER LEFT 385		01
09	0571017674	BAR LOWER FLIP LARGER		01
10	0571017673	BAR LOWER FLIP SMALLER		01
11	0503016881	5/16 UNC X 3/4 BOLT		04
12	0503012545	FLAT WASHER		04
13	0503012534	LOCK WASHER		04
14	0503012530	5/16" INOX NUT		04

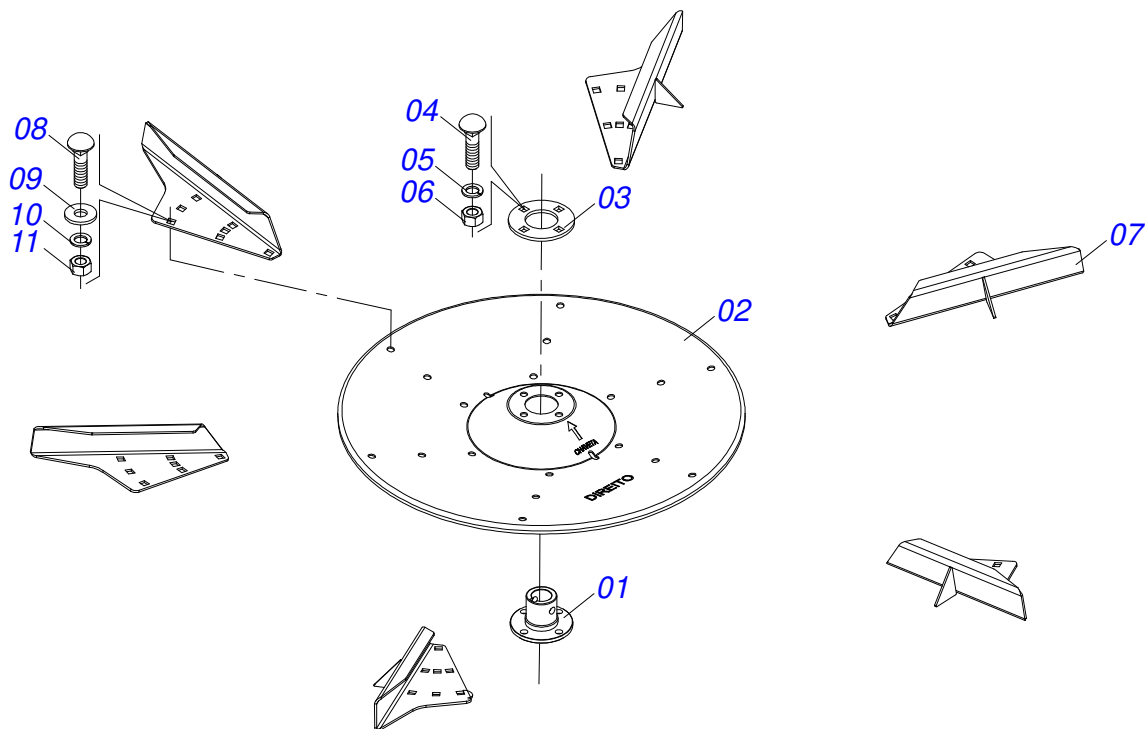

Item	Code	Description	See page	QT
01	0581010973	DISTRIBUTOR DISC SLEEVE		01
02	0581010971	RH DISC FERTILIZER BODY		01
03	0571013670	DISTRIBUTOR DISC FLANGE		01
04	0503012540	3/8" X 1" BOLT		04
05	0503012535	3/8" SPRING WASHER		04
06	0503012531	3/8" INOX NUT		04
07	0521065574	FLIP LIMESTONE RIGHT		06
08	0503016881	5/16 UNC X 3/4 BOLT		06
09	0503012545	FLAT WASHER		18
10	0503012534	LOCK WASHER		18
11	0503012530	5/16" INOX NUT		18

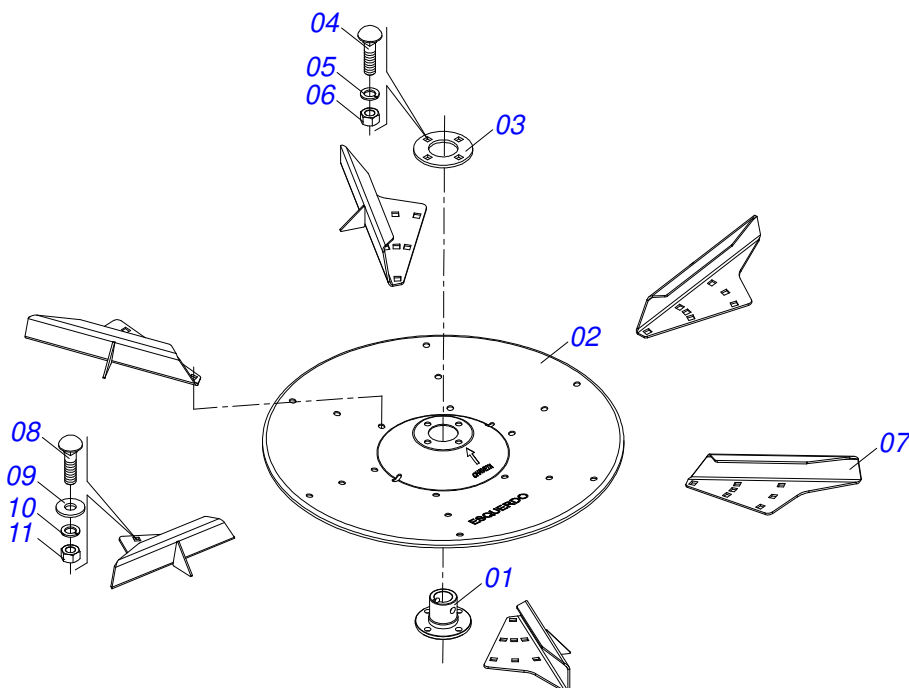

Item	Code	Description	See page	QT
01	0581010973	DISTRIBUTOR DISC SLEEVE		01
02	0581010972	LH DISC FERTILIZER BODY		01
03	0571013670	DISTRIBUTOR DISC FLANGE		01
04	0503012540	3/8" X 1" BOLT		04
05	0503012535	3/8" SPRING WASHER		04
06	0503012531	3/8" INOX NUT		04
07	0521065575	FLIP LIMESTONE LEFT		06
08	0503016881	5/16 UNC X 3/4 BOLT		18
09	0503012545	FLAT WASHER		18
10	0503012534	LOCK WASHER		18
11	0503012530	5/16" INOX NUT		18

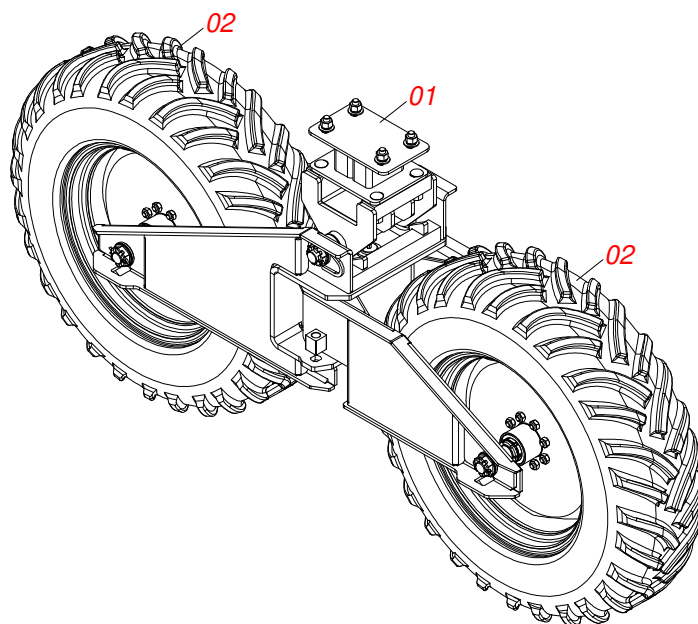

Item	Code	Description	See page	QT
01	0511053596	ASSEMBLY WHEEL WITHOUT TIRE RIGHT		01
02	0511059223	WHEEL WITH LEFT SIDE TIRE		02

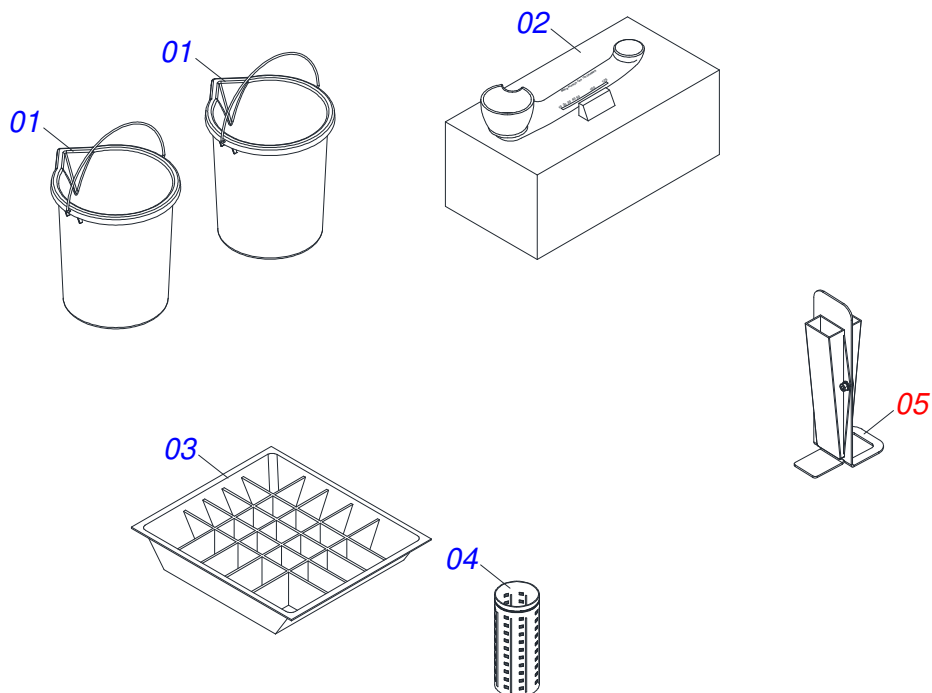

Item	Code	Description	See page	QT
01	0503017461	BUCKET GRADUATE 20LT		02
02	0503017463	MINI BALANCE		01
03	0503017464	TRAY COLLECTOR FERTILIZER		08
04	0503017698	GLASS CALIBRADOR 1000 ML		01
05	0511056596	SET PLUVIOMETER	20	01

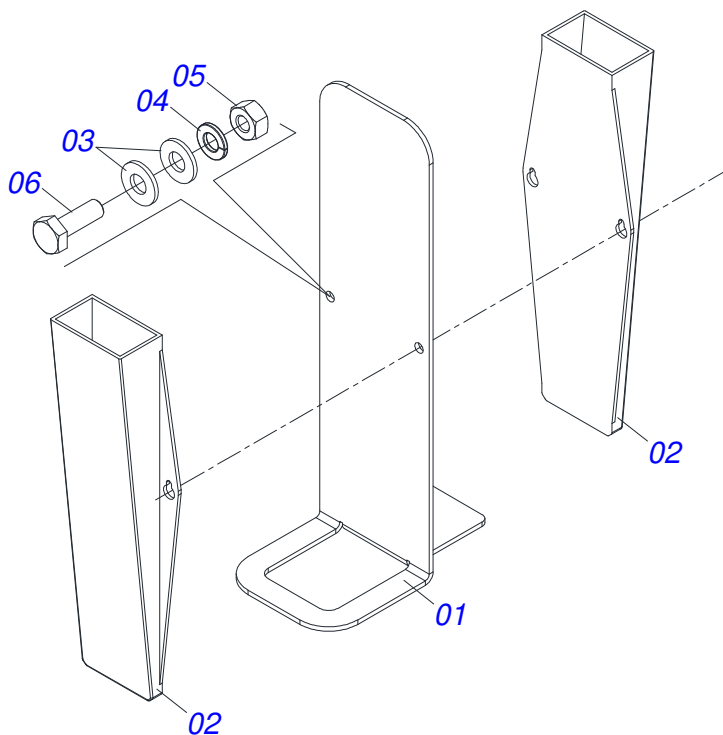

Item	Code	Description	See page	QT
01	0571017692	SUPPORT PLUVIOMETER		01
02	0503017462	PLUVIOMETER CAP 130 MM		02
03	0511017303	FLAT WASHER		04
04	0503010143	1/4" SPRING WASHER		02
05	0503010144	1/4" NUT		02
06	0503010282	1/4" X 3/4" BOLT		02

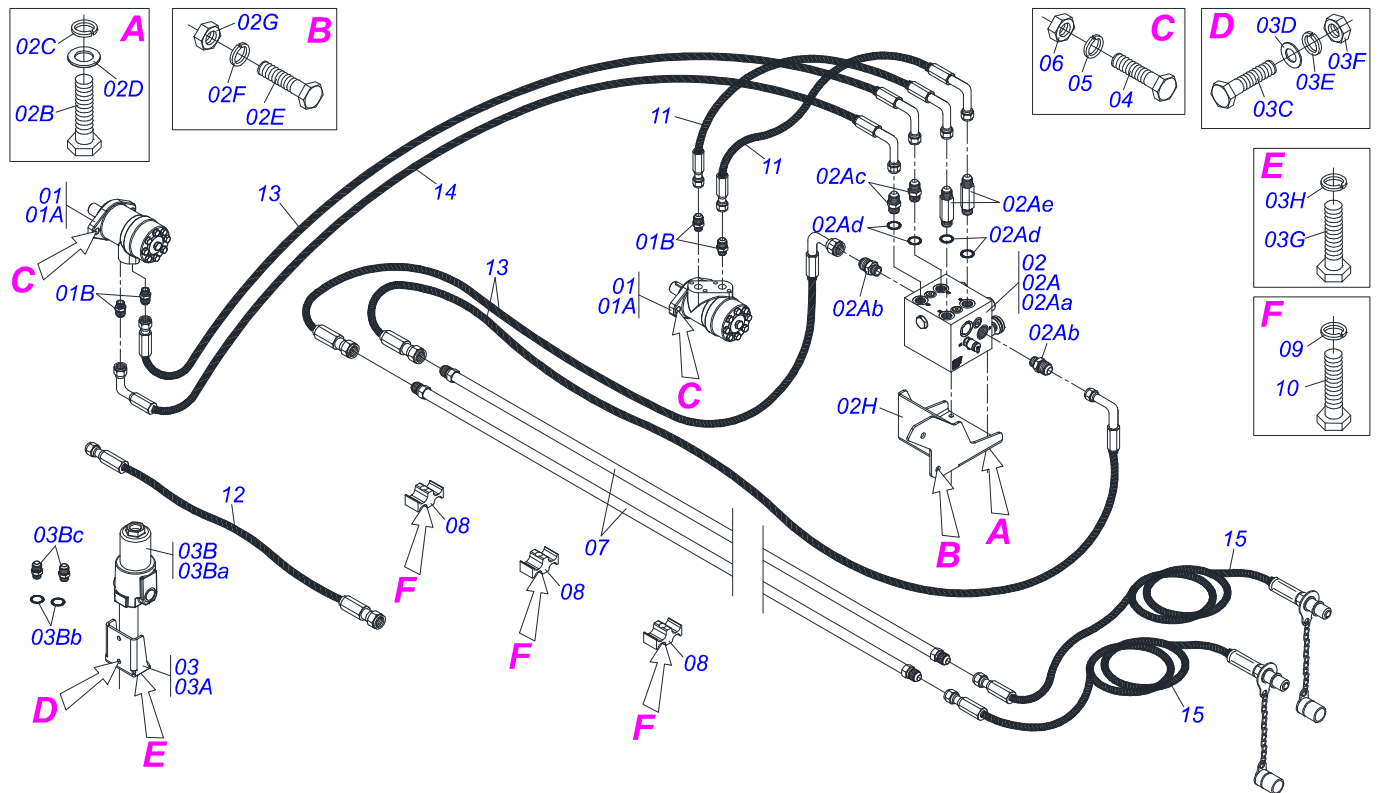

Item	Code	Description	See page	QT
01	0511053588	MOTOR HYDRAULIC OMP 80 WITH NIPPLE 7/8 NIPPE 7/8		02
01A	0503016055	PARKER OMP 80 ISOBUS HYDRAULIC MOTOR		02
01B	0511014065	7/8" NF X R1/2NPT X 52 NIPPLE		04
02	0511053807	BLOCK COMMAND HFB130315 WITH SUPORT		01
02A	0511053779	BLOCK COMMAND HFB130315 WITH NIPLES		01
02Aa	0503016515	BLOCK COMMAND		01
02Ab	0551011253	R1.1/16 JICX7/8 SAE S1.1/8X50 NIPPLE		02
02Ac	0501010590	NIPPLE		02
02Ad	0503010045	O'RING		04
02Ae	0501011510	NIPLE R 7/8 NF HEX 1 X 96		02
02B	0503010172	M10 X 1,5 X 25 BOLT		04
02C	0503010180	7/16" SPRING WASHER		04
02D	0501013519	FLAT WASHER		04
02E	0501010161	1/2" X 1.1/4" BOLT		02
02F	0503010019	1/2" SPRING WASHER		02
02G	0503010060	1/2 UNC G.5 ZN HEX NUT		02
02H	0571015452	SUPPORT BLOCK COMMAND		01
03	0511053806	FILTER SPRING TRIMBLE 80561		01
03A	0571014394	SUPPORT FILTER		01
03B	0511053778	FILTER SPRING TRIMBLE 80561 WITH NIPLE		01
03Ba	0503016335	FILTER SPRING TRIMBLE		01
03Bb	0503010045	O'RING		02
03Bc	0551011253	R1.1/16 JICX7/8 SAE S1.1/8X50 NIPPLE		02
03C	0503011087	3/8" X 1" BOLT		02
03D	0501013518	FLAT WASHER		02
03E	0503010025	3/8 SPRING WASHER		02
03F	0503010026	3/8" NUT		02
03G	0503014141	M6 X 1 X 20 BOLT		02
03H	0503010143	1/4" SPRING WASHER		02
04	0503010920	1/2 UNC X 1.1/2 C S G.5 ZN BOLT		04
05	0503010019	1/2" SPRING WASHER		04



**DCA MAX 12000 BT
SYSTEM HYDRAULIC**

Page 21
0511053812

Item	Code	Description	See page	QT
06	0503010060	1/2 UNC G.5 ZN HEX NUT		04
07	0521064188	2400 DCA TUBE		02
08	0502012702	BODY SUPPORT CLAMP		06
09	0503012555	SCREW 7/16 UNC X 2 CS RT G.7 ZN		06
10	0503010180	7/16" SPRING WASHER		06
11	0501080040	HOSE 1/2 X 500 TR-TC		02
12	0501080091	1/2" X 550 TR-TR HOSE		01
13	0501081235	1/2 X 650 TR- TC HOSE		03
14	0501011381	1/2 X 650 TC- TC 90G HOSE		01
15	0501081876	1/2 X 3000 TR- TM HOSE		02

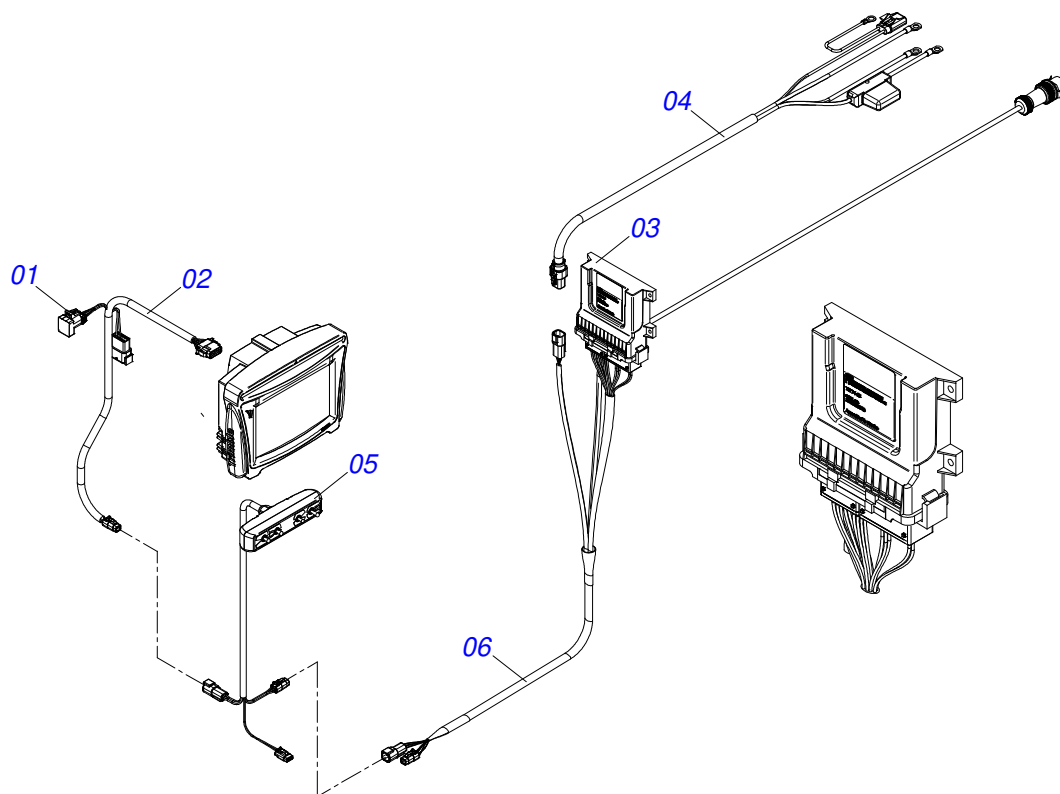

Item	Code	Description	See page	QT
01	0503016988	CORNER		01
02	0503062225	CABLE		01
03	0503016240	MODULE		01
04	0503062226	CABLE ASSY		01
05	0503062224	CONTROLLER		01
06	0503016990	CABLE TRIMBLE 88649		01

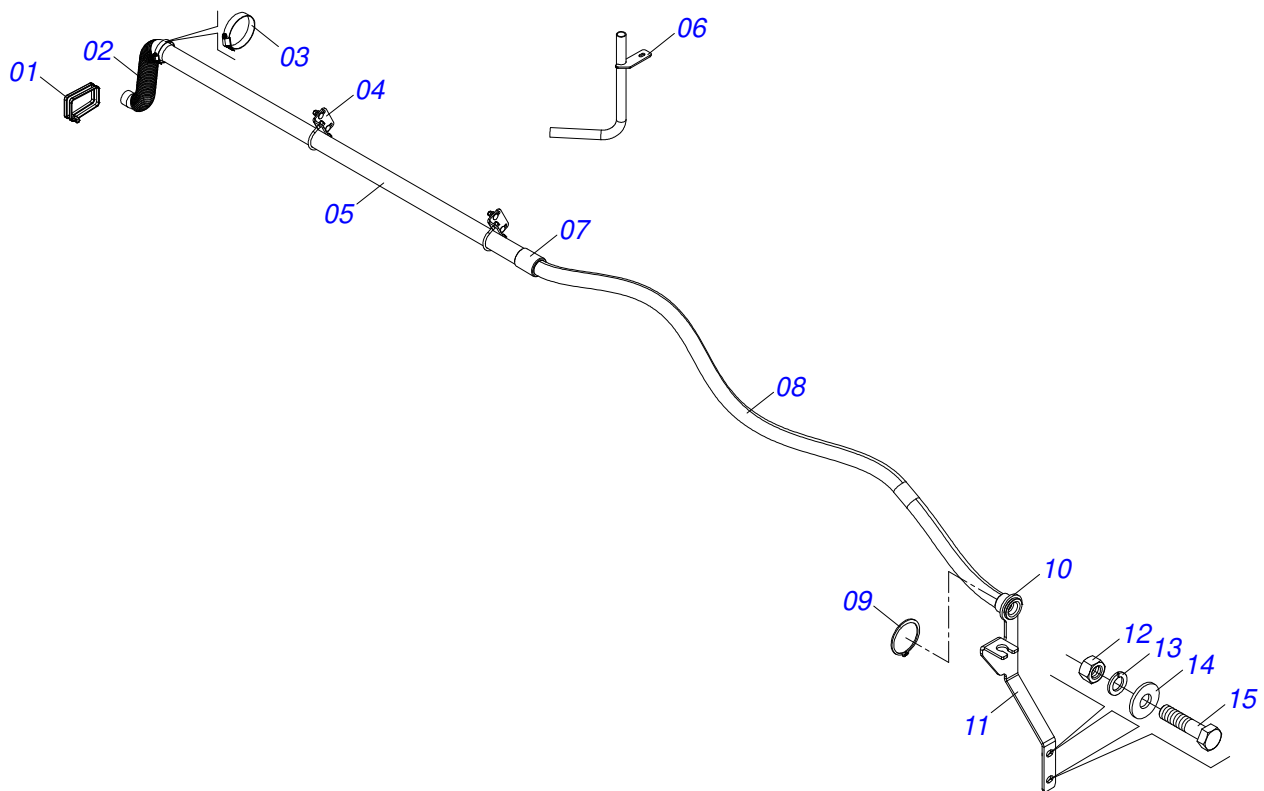

Item	Code	Description	See page	QT
01	0503010267	NYLON CLAMP		02
02	0503010368	1.1/2" X 2" X 12.2" HOSE		01
03	0503010246	CLAMP		01
04	0521046081	CONDUITE FIXING ASSY		02
05	0581010960	CONDUIT		01
06	0521066714	CONDUITE CURVO		01
07	0581010959	GLOVE CONDUIT		01
08	0581010961	HOSE		01
09	0503011416	RING		01
10	0581010958	CONDUIT SLEEVE		01
11	0581010957	SUPPORT BODY		01
12	0503010014	3/4" HEX NUT		02
13	0503010023	3/4" SPRING WASHER		02
14	0501017065	FLAT WASHER		02
15	0501010500	3/4" X 3" BOLT		02

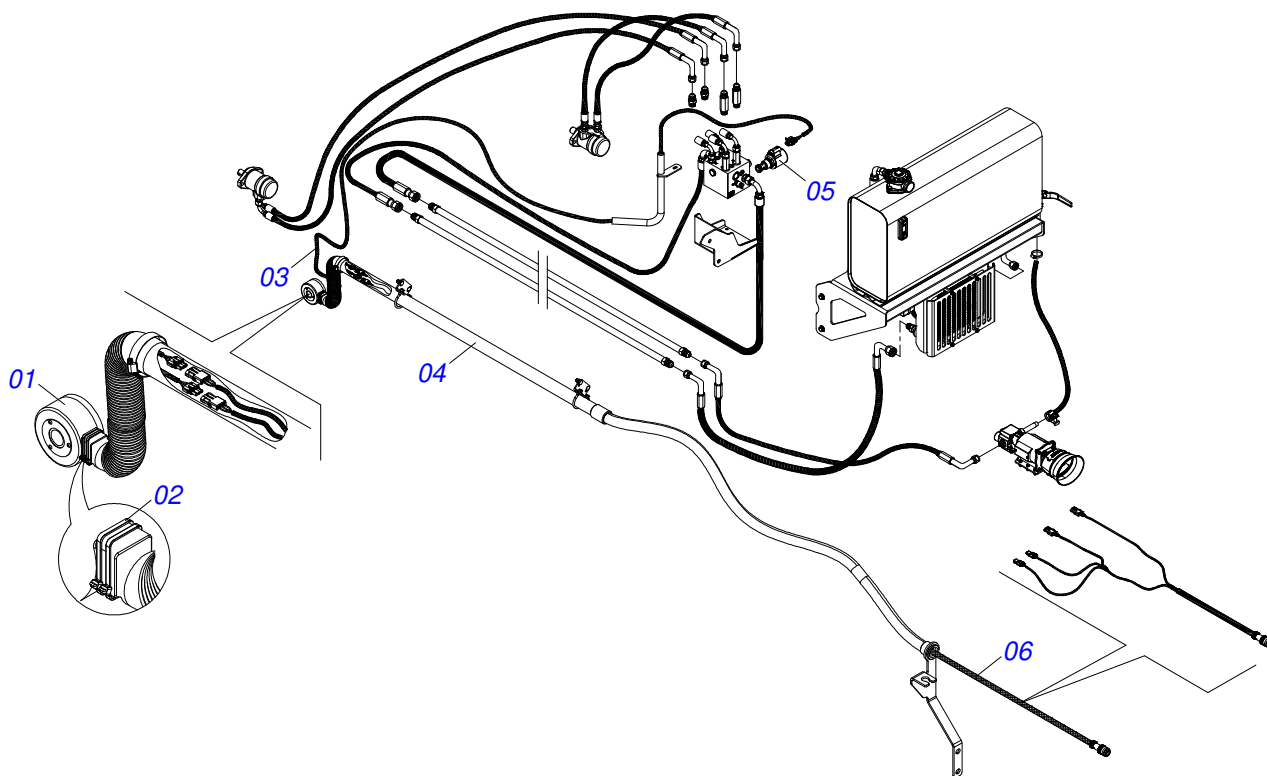

Item	Code	Description	See page	QT
01	0503016451	SENSOR		01
02	0503016033	4.8 X 1.3 X 300 MM NYLON CLAMP		30
03	0521050908	ADAPTER CABLE		01
04	0511058686	CONDUITE SET APT TRIMBLE	23	01
05	0503016978	VALVE		01
06	0503016989	CABLE		01



MARCHESAN

Technical Publications | Elaboration and Revision
JOSÉ DOMINGOS GASPARI

www.marchesan.com.br

