

# PARTS CATALOG

## FRONT LOADER

PD VALTRA 1680-4S/1880-4S  
S-0300

Code: 0501091423



Series: S-0300

Review: MARÇO/00

ORIGINAL PARTS  
TATU



# INDEX

0909090310	FRONT LOADER VTR1680-4S - 1880-4S	.....	1
0909090309	HYDRAULIC CIRCUIT VTR 1680 -1880-4S	.....	2
0909090269	HYDRAULIC CYLINDER	.....	3

**ATTENTION: IMPORTANT**

MARCHESAN RESERVES THE RIGHT AT ANY TIME TO MAKE IMPROVEMENTS IN THE DESIGN, MATERIAL OR SPECIFICATIONS OF MACHINERY, EQUIPMENT OR PARTS WITHOUT THEREBY BECOMING LIABLE TO MAKE SIMILAR CHANGES IN MACHINERY, EQUIPMENT OR PARTS PREVIOUSLY SOLD.

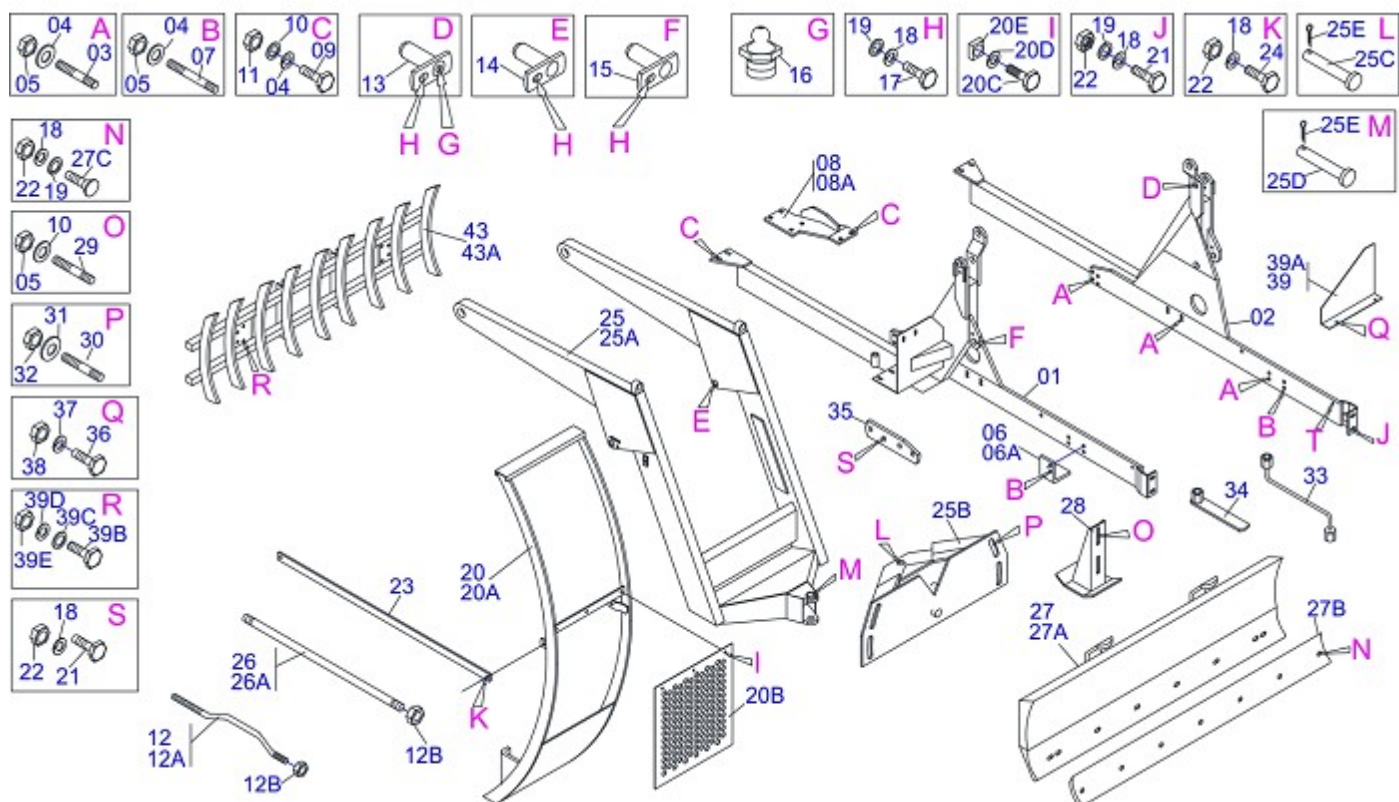

Item	Code	Description	QT
01	0511061745	RIGHT FRAME	01
02	0511061746	LEFT FRAME	01
03	0501010603	PRISONER M20 X 3/4 UNF X 95	10
04	0503010023	3/4" SPRING WASHER	18
05	0503010335	3/4" NUT	18
06	0511014395	FRONT AXLE BEATER	01
06A	0511014396	FRONT AXLE BEATER	01
07	0511014160	PRISONER M20 X 3/4 UNF X 115	04
08	0501064839	RH FRAME BRACKET	01
08A	0501064840	LH FRAME BRACKET	01
09	0501010500	3/4" X 3" BOLT	04
10	0501010322	FLAT WASHER	12
11	0503010014	3/4" NUT	04
12	0501047774	1.1/4" X 33.46" ROD	01
12A	0521010387	1.1/4" X 33.46" ROD CURVED	01
12B	0501010087	1.1/4" UNC NUT	12
13	0501063751	1.5" X 5.5" PIVOT SHAFT	02
14	0501063958	1.5" X 4.3" PIVOT SHAFT LOCK	02
15	0501063959	PIVOT SHAFT	02
16	0503010002	GREASE FITTING	02
17	0503010962	5/8" X 1-1/4" BOLT	06
18	0503010027	5/8" SPRING WASHER	22
19	0501012140	FLAT WASHER	24
20	0501049367		01
20A	0511061956		01
20B	0501014687	FRONT PROTECTION	01
20C	0503010751	3/8" X 1.1/4" HEX BOLT G.5	03
20D	0501010984	FLAT WASHER	03
20E	0501011338	3/8" SQUARE NUT	03
21	0501010100	5/8" X 2" BOLT	04
22	0503010013	5/8" NUT	16
23	0521017844	1730 ATTACHMENT BAR	02
24	0503010232	5/8" X 1.3/4" BOLT	02



Item	Code	Description	QT
25	0501044604	MOBILE SUPPORT ASSY	01
25A	0501066834	MOBILE SUPPORT	01
25B	0501062637	5/8" REGULATOR SUPPORT	01
25C	0521010612	1.4" X 3.5" COUPLING SHAFT	01
25D	0521010618	1.4" X 8.6" COUPLING SHAFT	01
25E	0503010010	1/4" X 2.1/2" COTTERPIN	02
26	0501041427	1.1/4" NC X 1540 ROD	02
26A	0501014250	1.1/4" X 1540 ROD	02
27	0501047710	2600MM BLADE SUPPORT ASSY	01
27A	0501068001	2590MM BLADE SUPPORT ASSY	01
27B	0622360011	2600 SCRAPER REVERSIBLE	01
27C	0501012240	5/8" X 2-1/2" BOLT	08
28	0501063411	ESTABILIZER BRACKET	02
29	0501010571	3/4 NC X 3/4 NF X 56 PRISONER	04
30	0501010572	1 UNC X 1 UNS X 76 PRISONER	04
31	0501010574	FLAT WASHER	04
32	0503010340	1" UNF NUT	04
33	0501068213	5/8" WRENCH DOUBLE	01
34	0501061617	1" WRENCH CYLINDRICAL HEX	01
35	0521018671	RIGHT RADIATOR PROTECTION	01
35A	0521018672	LEFT RADIATOR PROTECTION	01
36	0108010002	9 TEETH ROTH RAKER	01
36A	0501060958	9 TEETH ROTH RAKER	01
36B	0501010276	1" X 3" BOLT	04
36C	0501010065	FLAT WASHER	04
36D	0503010012	1" SPRING WASHER	04
36E	0501010059	1" NUT HEX	04

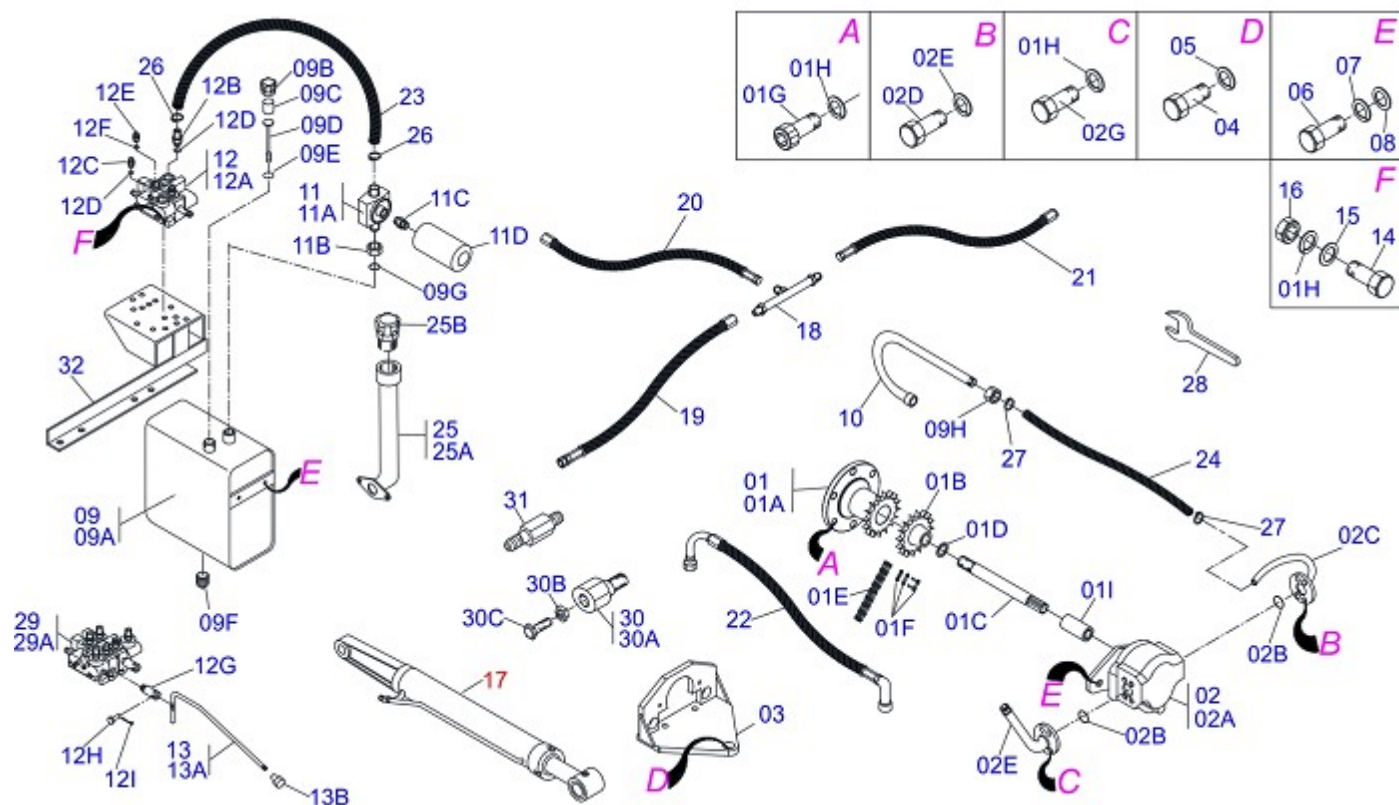

Item	Code	Description	QT
01	0501048930		01
01A	0501066770		01
01B	0502040508	16Z GEAR	01
01C	0511061497	10.82" X 7/8" AXLE	01
01D	0501010890	FLANGE WASHER	01
01E	0503010455	50-2 CHAIN X 15 LINK + MENDING	01
01F	0503010560	AMENDMENT WITH LOCK	01
01G	0503011313	M8 X 2" BOLT	06
01H	0503010025	3/8" SPRING WHASHER	13
01I	0503030838	1-1/8" X 2.4" SLEEVE	01
02	0501046870	PUMP WITH TUBE	01
02A	0503060045	40L 1/2" PUMP	01
02B	0503010173	2-220 N 3006-9B O'RING	02
02C	0501061277	PUMP SUCTION TUBE	01
02D	0503010355	7/16" X 1" BOLT	04
02E	0503010180	7/16" SPRING WASHER	04
02F	0501067719	PUMP PRESSURE TUBE	01
02G	0503010237	3/8" X 1" HEX BOLT G5	04
03	0501064140	PUMP SUPPORT	01
04	0503010148	M16 X 2 X 40 BOLT	03
05	0503010027	5/8" SPRING WASHER	03
06	0501010161	1/2" X 1-1/4" BOLT	06
07	0503010019	1/2" SPRING WASHER	06
08	0511017302	FLAT WASHER	06
09	0501047807	RESERVOIR OIL ASSY	01
09A	0501068880	RESERVOIR OIL	01
09B	0502020472	TANK COVER BODY	01
09C	0503030044	FILTERING ELEMENT	01
09D	0501060975	OIL GAGE	01
09E	0503010185	2-221 N 3006-9B O'RING	01
09F	0503031604	1/2" BSP PLUG	01
09G	0503010046	2-216 N 3006-9B O'RING	01
09H	0501016309	2" 1X 2.5/16" NUT	01



## HYDRAULIC CIRCUIT VTR 1680 -1880-4S

0909090309

Item	Code	Description	QT
10	0501063383	TANK OUTER TUBE	01
11	0501041108	RETURNING FILTER ASSY	01
11A	0502050002	RETURNING FILTER HEAD	01
11B	0501010594	1" NUT HEX	01
11C	0501010595	1" NF NIPPLE	01
11D	0503010183	RETURNING FILTER	01
12	0501040871	1/2" COMMAND SIMPLE ASSY	01
12A	0503060080	1/2" COMMAND SIMPLE	01
12B	0501010591	HOSE NIPPLE	01
12C	0501010589	1-1/16 NIPPLE	01
12D	0503010602	2-211 N 3006-9B O'RING	02
12E	0501010590	7/8" REDUCTION NIPPLE	02
12F	0503010045	2-116 N 3006-9B O'RING	02
12G	0503030347	UPPER LEVER ASSY (SAUER DANFOSS)	01
12H	0521010533	0.3" X 1" COUPLING SHAFT	01
12I	0503010140	1/8" X 3/4" COTTERPIN	01
13	0501048023	CONTROL VALVE	01
13A	0511060695	CONTROL VALVE	01
13B	0503030878	LEVER CRANK	01
14	0501010080	3/8" X 1-1/2" BOLT	03
15	0501010984	FLAT WASHER	03
16	0503010026	3/8" NUT	03
17	0501040161	RIGHT HYDRAULIC CYLINDER	01
17A	0501040162	LEFT HYDRAULIC CYLINDER	01
18	0501068942	"T" CONNECTION NIPPLES	02
19	0501080021	1/2" X 51" TR-TR HOSE ASSY	02
20	0501080022	1/2" X 43" TR-TR HOSE ASSY	02
21	0501080336	1/2" X 2450 TR-TR HOSE	02
22	0501080712	3/4" X 3000 TC-TC HOSE ASSY	01
23	0501019999	1" X 43.3" HOSE ASSY	01
24	0511010498	HOSE CLAMP 1.1/4" X 72.83"	01
25	0501047999	TANK COVER PROTRACTOR	01
25A	0501065168	TANK COVER PROTRACTOR	01
25B	0502020549	TANK COVER	01
26	0503010184	1-1/4" TO 1-1/2" CLAMP	02
27	0503010243	1-1/2" TO 2" CLAMP	02
28	0511010153	2-5/16" FIXED WRENCH	01
29	0501040873	1/2" DOUBLE COMMAND	01
29A	0503060081	1/2" DOUBLE COMMAND	01
30	0501051748	ADAPTER ASSY	02
30A	0511016921	ADAPTER BODY BOLT BEATER	02
30B	0521010905	M16 X 08" X 0.23" PD V 1380-4S NUT	02
30C	0521010906	M16 X 2 X 50 BOLT	02
31	0511015888	RADIATOR OIL TUBE ADAPTER	02
32	0501069824	SUPPORT CONTROL VALVE	01

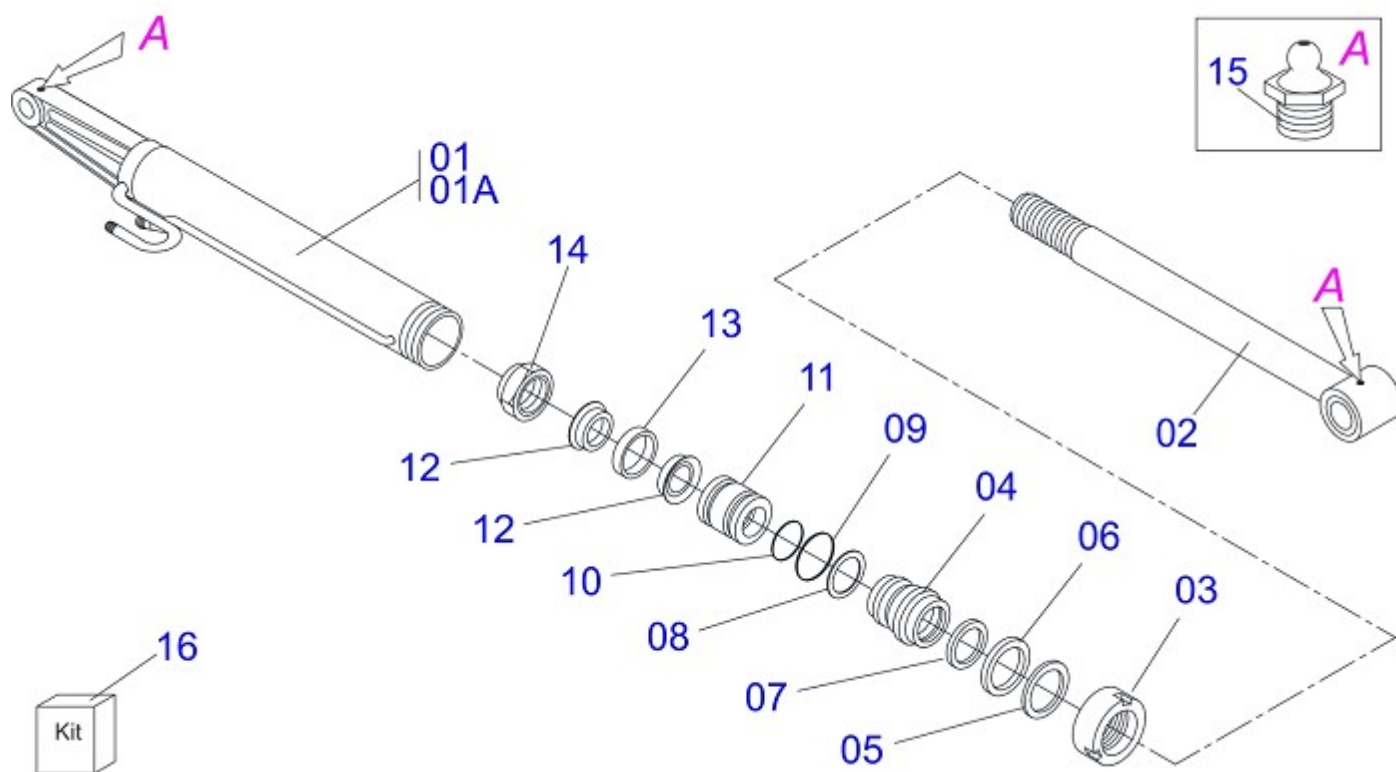

Item	Code	Description	
00	0501040161	RIGHT HYDRAULIC CYLINDER	
00A	0501040162	LEFT HYDRAULIC CYLINDER	
01	0501063658	RH 101,6 X 472 CYLINDER CASE	01
01A	0501063659	LH 101,6 X 472 CYLINDER CASE	01
02	0501068966	HYDRAULIC CYLINDER TURNBUCKLE	01
03	0502010017	4" HEAD	01
04	0502010778	2" X 4.2" RING SUPPORT	01
05	0503010039	D-2000 SCRAPER RING	01
06	0503010991	PACKING 1870-2000-375-B	01
07	0503010952	W2-2250-500 PK RING G.E	01
08	0503011061	8-342 BACK-UP RING	01
09	0503010338	2-342 N 3006-9B O'RING	01
10	0503010345	2-218 N 3006-9B O'RING	01
11	0502010992	2.0" X 4.0" PISTON	01
12	0503010043	PACKING 3750-3250	02
13	0503010994	W2-4000-500 PK RING G.E	01
14	0503010817	1.1/4" UNF SELF ADJUSTING NUT	01
15	0503010002	GREASE FITTING	02
16	0501031799	HYDRAULIC CYLINDER REPAIR KIT	01







**MARCHESAN**

**MARCHESAN IMPLEMENTOS E MÁQUINAS AGRÍCOLAS TATU S.A.**

AV. Marchesan, 1979 - Post office box, 131 - CEP 15994-900 - Matão - SP - Brazil

Phone +55 16.3382-8282

(FAX Parts) + 55 16.3382. 8297 - (Export) + 55 16.3382.1003

e.mail: [tatu@marchesan.com.br](mailto:tatu@marchesan.com.br) [www.marchesan.com.br](http://www.marchesan.com.br)

*Drafting and Illustration = GASPARI  
e.mail = [jgaspari@marchesan.com.br](mailto:jgaspari@marchesan.com.br)*

**ORIGINAL PARTS  
TATU**



**MARCHESAN**