

CATÁLOGO DE PIEZAS

PALAS DELANTERAS

PD MF L600 660-4 SHT S-0195

Código: 0501091404



Serie: S-0195

Revisión: JANEIRO/95

PIEZAS ORIGINALES
TATU



INDICE

0909091295	1
0909091298	2
0909091296	CIRCUITO HIDRAULICO	3

ATENCIÓN: **IMPORTANTE**

MARGESAN SE RESERVA EL DERECHO DE PERFECCIONAR Y/O MODIFICAR LAS CARACTERÍSTICAS TÉCNICAS DE SUS PRODUCTOS, SIN LA OBLIGACIÓN DE PROCEDER CON LOS YA COMERCIALIZADOS Y SIN CONOCIMIENTO PREVIO DEL DISTRIBUIDOR AUTORIZADO O DEL CONSUMIDOR.

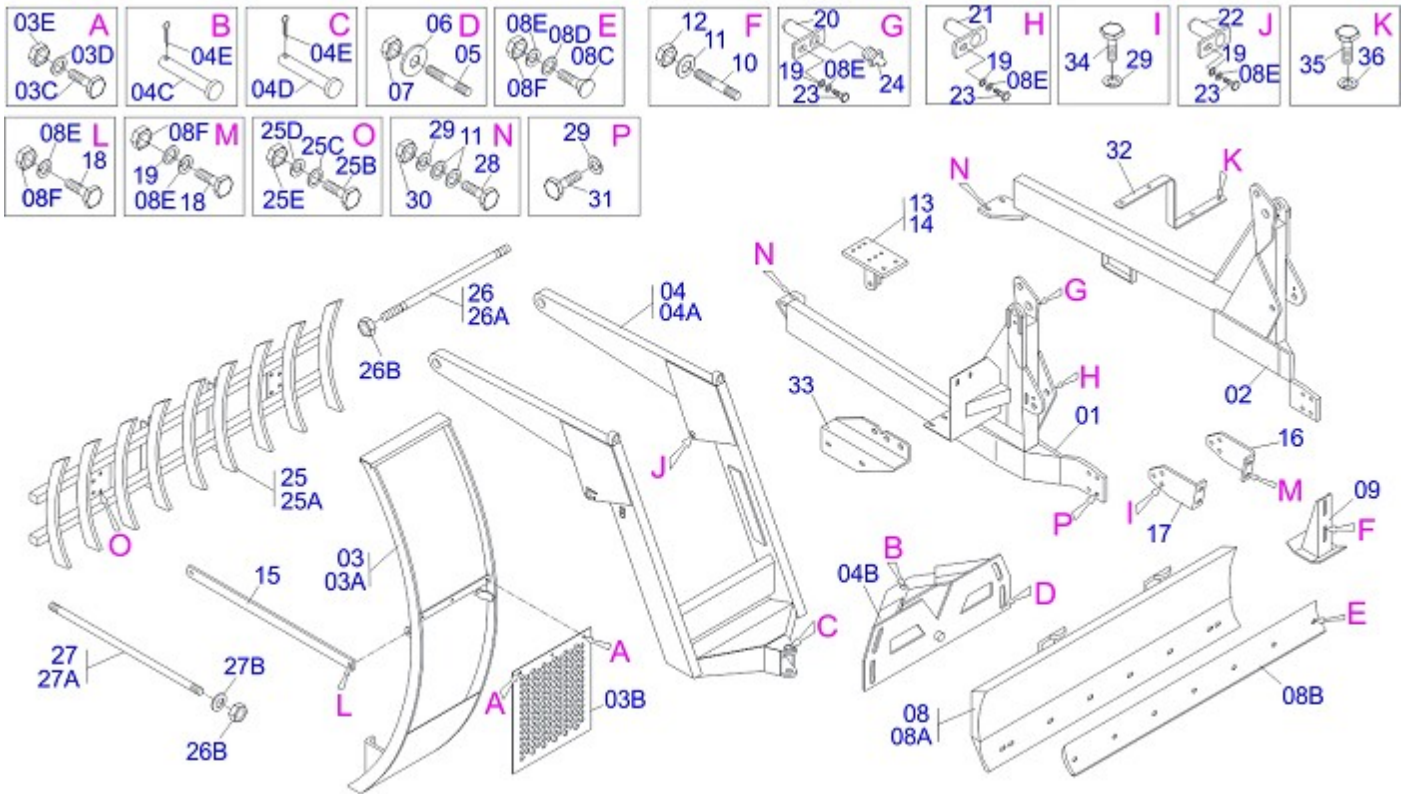

Artículo	Código	Descripción	
01	0501067040	CHASIS DERECHO	01
02	0501067041	CHASIS IZQUIERDO	01
03	0501044583		01
03A	0501067784		01
03B	0511014657		01
03C	0503010751	TORNILLO 3/8" UNC X 1.1/4"	03
03D	0501010984	ARANDELA PLANA	03
03E	0503010026	TUERCA 3/8"	03
04	0501044604	SOPORTE MOVIL COMPL	01
04A	0501066834	SOPORTE MOVIL	01
04B	0501062637	SOPORTE REGULACION	01
04C	0521010618	EJE UNION 37,50 X 220	01
04D	0521010613	EJE UNION 37,5 X 100	01
04E	0503010010	PASADOR ABIERTO 1/4 X 2.1/2	02
05	0501010572	PRISIONERO 1 UNC X 1 UNS X 76	04
06	0501010574	ARANDELA PLANA	04
07	0503010340	TUERCA 1" UNF	04
08	0501047710	SOPORTE CUCHILLA 2600 COMPL	01
08A	0501068001	SOPORTE CUCHILLA 2590	01
08B	0622360011	RASPADOR REVERSIBLE 2400	01
08C	0501812240		08
08D	0501810301	ARANDELA PLANA	08
08E	0503011445	ARANDELA PRESION 5/8"	20
08F	0503810013	TUERCA 5/8" NC	14
09	0501063411	ZAPATA ESTAB	02
10	0501010571	PRISIONERO 3/4 NC X 3/4 NF X 56	04
11	0501010322	ARANDELA PLANA	12
12	0503010335	TUERCA 3/4" UNF	04
13	0501067262		01
14	0501067263		01
15	0511015529		02
16	0511017248		01
17	0511017249		01

Artículo	Código	Descripción	
18	0501010100	TORNILLO 5/8" UNC X 2"	06
19	0501012140	ARANDELA PLANA	10
20	0501063958	EJE ARTIC TRABA 37,2 X 110	02
21	0501063959	EJE ARTICULACION CON TRABA	02
22	0501063751	EJE ARTIC 37,2 X 140	02
23	0503010962	TORNILLO 5/8" UNC X 1.1/4"	06
24	0503010002	GRASERA 1800	02
25	0108010002	HILERADOR AGR 9 DIENTES	02
25A	0501060958	DESENRAIZADOR ENLEIRADOR 9 DIENTES	01
25B	0501010276	TORNILLO 1UNC X 3"	04
25C	0501010623	ARANDELA PLANA	04
25D	0503010012	ARANDELA PRESION 1"	04
25E	0503010059	RODAMIENTO 33287/33462	04
26	0501041849	VARON 1.1/4" NC X 910	01
26A	0501014914	VARON 1.1/4" X 910	01
26B	0501010087	TUERCA 1.1/4" UNC 7FPP	12
27	0501041427	VARON 1.1/4" NC X 1540	01
27A	0501014250	VARON 1.1/4" X 1540	01
27B	0502012180	ARANDELA TENSORA	02
28	0501010500	TORNILLO 3/4" UNC X 3"	04
29	0503010023	ARANDELA PRESION 3/4"	18
30	0503010014	TUERCA 3/4" UNC	04
31	0501018059	TORNILLO 3/4" UNC X 2.1/4"	08
32	0531017226		02
33	0511016977		01
34	0501011544	TORNILLO 3/4" UNC X 1.1/2"	06
35	0503011102	TORNILLO 7/16" UNC X 1.1/4"	04
36	0503010180	ARANDELA PRESION 7/16"	04

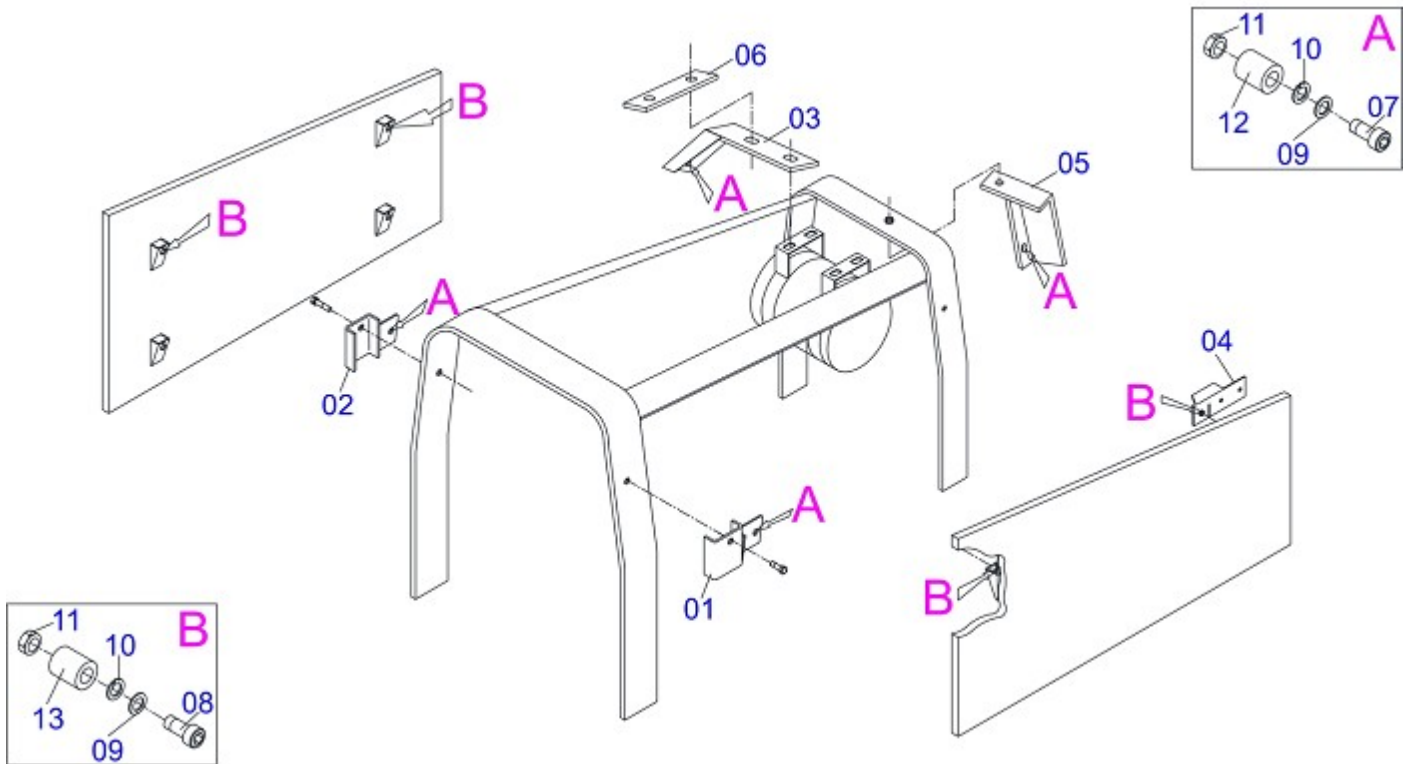

Artículo	Código	Descripción	
01	0501066793	SOPORTE FIJADOR CAPUCHA DERECHO	01
02	0501066794	SOPORTE FIJADOR CAPUCHA IZQUIERDO	01
03	0501066795	SOPORTE FIJADOR CAPUCHA TRASERO	01
04	0501068307	SOPORTE COJÍN CAPUCHA DELANTERO DER	01
05	0511066525	SOPORTE FIJA CAPUCHA DERECHO	01
06	0531015896	TRAVA SOPORTE FIJA CAPUCHA	01
07	0503010376	TORNILLO 5/16" UNC X 1"	04
08	0503011363	TORNILLO 5/16" UNC X 1.1/4"	04
09	0501010694	ARANDELA PLANA	08
10	0503010179	ARANDELA PRESION 5/16"	08
11	0503010337	TUERCA 5/16" UNC	08
12	0503011314	APOYO	04
13	0503011315	AMORTIGUADOR	04

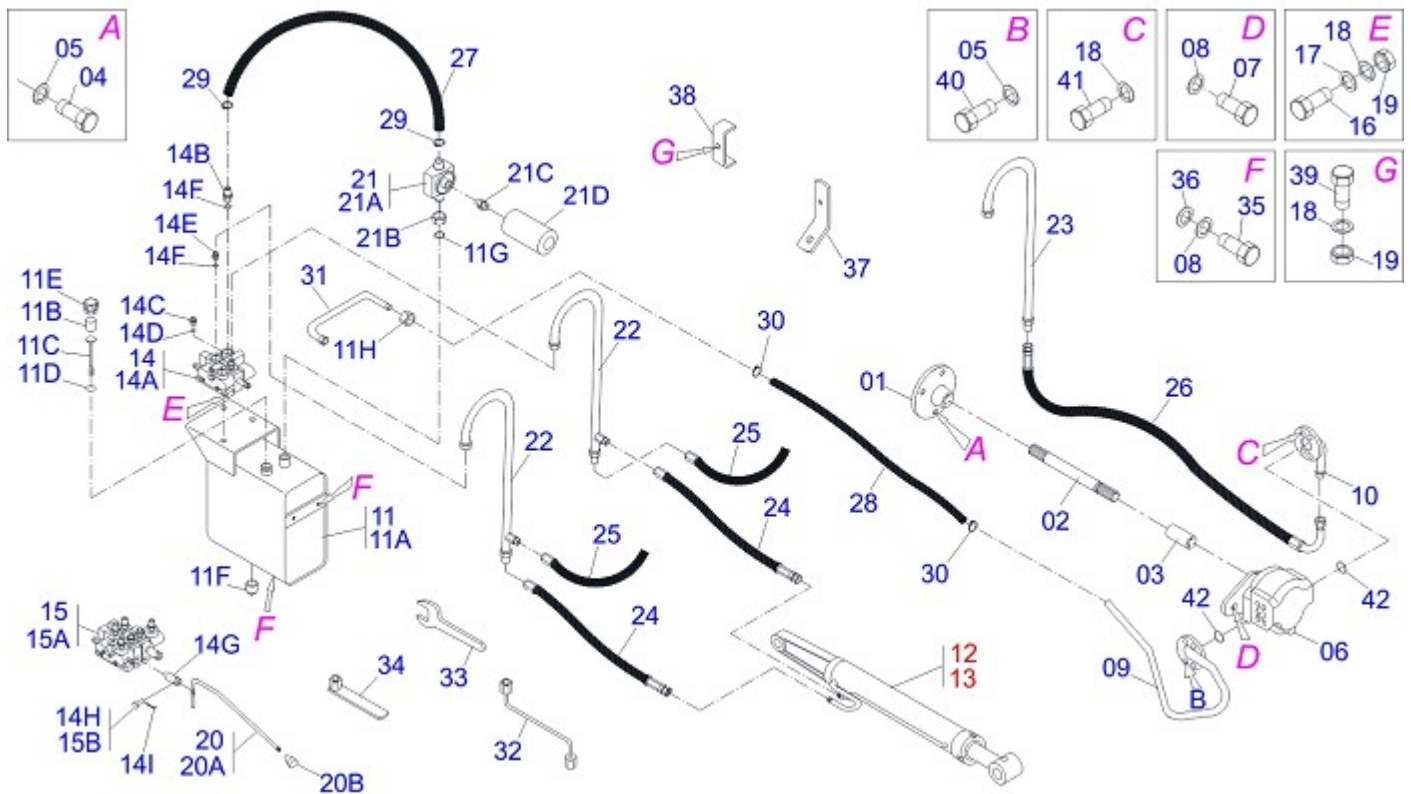

Artículo	Código	Descripción	CS	CD
01	0503050056	BRIDA ACOPLAMIENTO	01	01
02	0503030881	EJE 695 X 1.1/8 ESTR X 1.1/8-30G	01	01
03	0503030838	BUJE 1.1/8" X 61 ESTR	01	01
04	0503010119	TORNILLO 7/16" UN X 1.1/4"	04	04
05	0503010180	ARANDELA PRESION 7/16"	08	08
06	0503060153	BOMBA 40L 1/2"	01	01
07	0503010920	TORNILLO 1/2" UNC X 1.1/2"	02	02
08	0503010019	ARANDELA PRESION 1/2"	06	06
09	0501066833	DUCTO SUCCION BOMBA	01	01
10	0501066832	DUCTO PRESION BOMBA	01	01
11	0501047808	RESERVOIR OLEO COMPLETO	01	01
11A	0501068882	RESERVOIR OLEO	01	01
11B	0503030044	ELEM FILTRANTE AR	01	01
11C	0501060975	MEDIDOR ACEITE	01	01
11D	0503010185	ANILLO O'RING 2-221 N 3006-9B	01	01
11E	0502020472	CUERPO TAPA TANQUE	01	01
11F	0503031604	TAPON 1/2 BSP	01	01
11G	0503010046	ANILLO O'RING 2-216 N 3006-9B	01	01
11H	0501016309	TUERCA 2" UNC 16FPP X 2.5/16"	01	01
12	0501040161	CILINDRO HIDRAULICO 50,8 X 101,6 X 1028 X 472	01	01
13	0501040162	CILINDRO HIDRAULICO 50,8 X 101,6 X 1028 X 472	01	01
14	0501040871	COMANDO 1/2" COMPLETO	01	
14A	0503060080	COMANDO 1/2"	01	
14B	0501010591	BICO P/MANGUERA	01	01
14C	0501010589	NIPLE 1.1/16UN	01	01
14D	0503010602	ANILLO O'RING 2-211 N 3006-9B	02	02
14E	0501010590	NIPLE 7/8 NF HEX 1 X 48	02	04
14F	0503010045	ANILLO O'RING 2-116 N 3006-9B	02	04
14G	0503030347	FIJADOR SUP PALANCA (SAUER DANFOSS)	01	02
14H	0503010593	ANILLO O'RING 2-154 N 3000-7B	01	
14I	0503010140	PASADOR ABIERTO 1/8" X 3/4"	01	02
15	0501040873	COMANDO DOBLE 1/2"	01	
15A	0503060081	COMANDO DOBLE 1/2"	01	



Artículo	Código	Descripción	CS CD
15B	0521010532	EJE UNION 7,93 X 23	02
16	0501010080	TORNILLO 3/8" UNC X 1.1/2"	03 03
17	0501010984	ARANDELA PLANA	03 03
18	0503010025	ARANDELA PRESION 3/8"	08 08
19	0503010026	TUERCA 3/8"	04 04
20	0501045092	PALANCA COMANDO COMPL.	01 02
20A	0501067116	PALANCA COMANDO COMPL.	01 01
20B	0503030878	MANOPLA PALANCA	01 01
21	0501041108	FILTRO RETORNO MAYOR COMPL	01 01
21A	0502050002	CABCT FILTRO RETORNO	01 01
21B	0501010594	TUERCA 1" BSP S 1.5/8"	01 01
21C	0501010595	NIPLE 1 NF SEXT.1.1/8 X 37	01 01
21D	0503010183	FILTRO RETORNO	01 01
22	0501068945	CONEXION CURVO	02 02
23	0501064350	DUCTO PRESION COMANDO	01 01
24	0501080033		02 02
25	0501080102	MANG 1/2" X 2200 TR-TR	02 02
26	0501080202		01 01
27	0501013822	MANGUERA 1 X 650 AB-AB	01 01
28	0501013823		01 01
29	0503010184	ABRAZADERA 1.1/4 A 1.1/2	02 02
30	0503010243	ABRAZADERA 1.1/2" A 2"	02 02
31	0501067815	DUCTO SALIDA TANQUE	01 01
32	0501068213	CLAVE DOBLE 5/8 X 3/4	01 01
33	0511010153	CLAVE FIXA 2.5/16	01 01
34	0501061617	CLAVE 1 CABO PLANO	01 01
35	0501010161	TORNILLO 1/2" UNC X 1.1/4"	04 04
36	0511017302	ARANDELA PLANA	04 04
37	0511014792		01 01
38	0511012725	PRESILLA DISTRIBUIDOR OLEO	01 01
39	0501011048	TORNILLO 3/8" UNC X 2.1/2"	01 01
40	0503010355	TORNILLO 7/16" UNC X 1"	04 04
41	0503010237	TORNILLO 3/8" UNC X 1"	04 04
42	0503010173	ANILLO O'RING 2-220 N 3006-9B	02 02



MARCHESAN IMPLEMENTOS E MÁQUINAS AGRÍCOLAS TATU S.A.

AV. Marchesan, 1979 - Casilla de Correos, 131 - CEP 15994-900 - Matão - SP - Brasil

Fono: +55 16.3382-8282

(FAX Venta)+55 16.3382.8297 - (Exportar) + 55 16.3382.1003

e.mail: tatu@marchesan.com.br

Home Page: www.marchesan.com.br

Redaccion e Ilustracion = GASPARI
e.mail = jgaspari@marchesan.com.br

**PIEZAS ORIGINALES
TATU**

