

CATÁLOGO DE PIEZAS

PALAS DELANTERAS

PD MF 283-4 A 290-4 ADV S-0702

Código: 0501091401



Serie: S-0702

Revisión: JULHO/02

PIEZAS ORIGINALES
TATU



INDICE

0909091266		1
0909091265	CIRCUITO HIDRAULICO	2

ATENCIÓN: **IMPORTANTE**

MARGHESAN SE RESERVA EL DERECHO DE PERFECCIONAR Y/O MODIFICAR LAS CARACTERÍSTICAS TÉCNICAS DE SUS PRODUCTOS, SIN LA OBLIGACIÓN DE PROCEDER CON LOS YA COMERCIALIZADOS Y SIN CONOCIMIENTO PREVIO DEL DISTRIBUIDOR AUTORIZADO O DEL CONSUMIDOR.

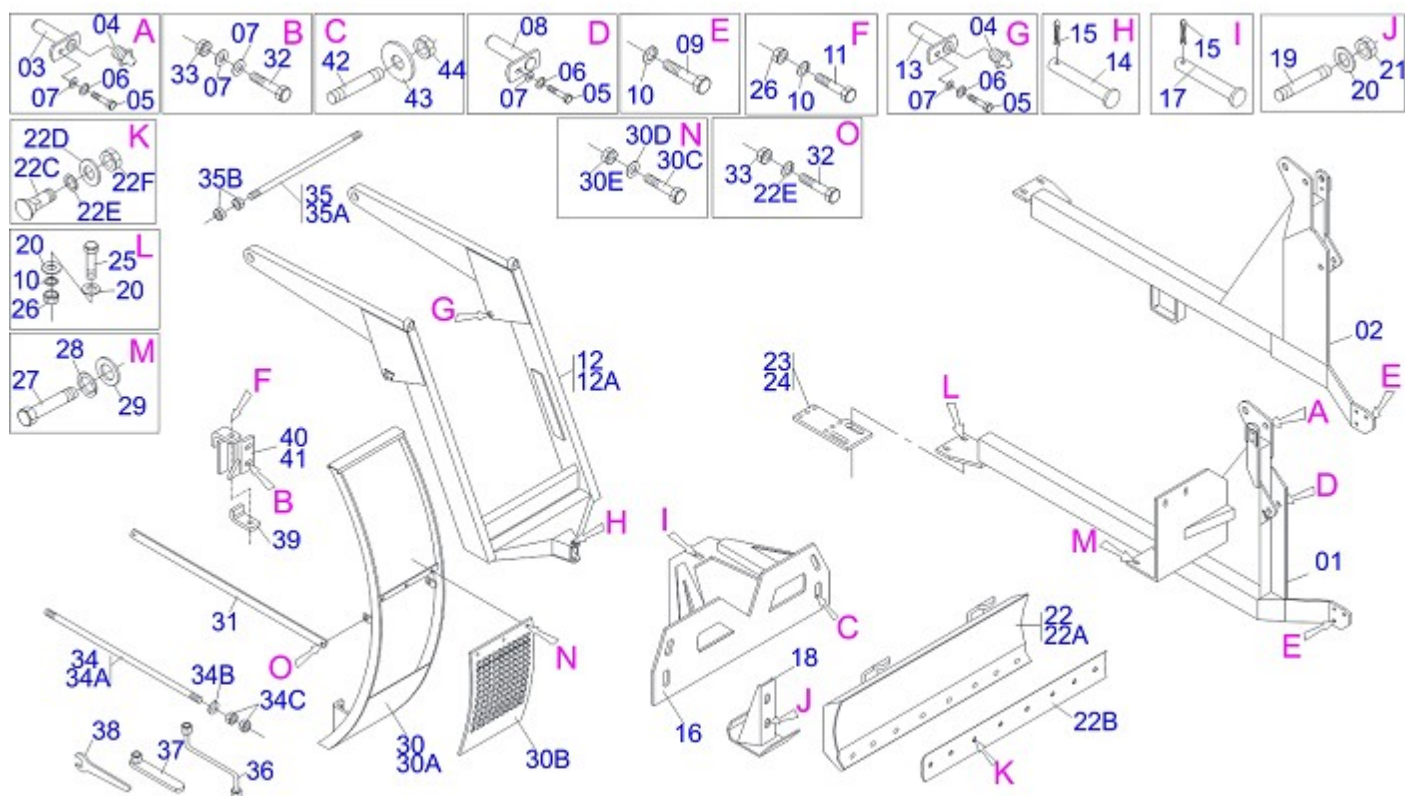

Artículo	Código	Descripción	QT
01	0501069138	CHASIS DERECHO	01
02	0501069139	CHASIS IZQUIERDO	01
03	0501063959	EJE ARTICULACION CON TRABA	02
04	0503010002	GRASERA 1800	04
05	0503010962	TORNILLO 5/8" UNC X 1.1/4"	06
06	0503010027	ARANDELA PRESION 5/8"	06
07	0501012140	ARANDELA PLANA	14
08	0501063958	EJE ARTIC TRABA 37,2 X 110	02
09	0501010098	TORNILLO 3/4" UNC X 2"	06
10	0503010023	ARANDELA PRESION 3/4"	12
11	0511016281	TORNILLO 3/4" UNC X 8"	02
12	0501047979		01
13	0501063751	EJE ARTIC 37,2 X 140	02
14	0521010613	EJE UNION 37,5 X 100	01
15	0503010010	PASADOR ABIERTO 1/4 X 2.1/2	02
16	0501062637	SOPORTE REGULACION	01
17	0521010618	EJE UNION 37,50 X 220	01
18	0501063411	ZAPATA ESTAB	02
19	0501010571	PRISIONERO 3/4 NC X 3/4 NF X 56	04
20	0501010322	ARANDELA PLANA	12
21	0503010335	TUERCA 3/4" UNF	04
22	0501047708	SOPORTE CUCHILLA 2400	01
22A	0501067999	SOPORTE CUCHILLA 2390	01
22B	0622360016	RASPADOR REVERSIBLE 2400	01
22C	0501012240	TORNILLO 5/8" UNC X 2.1/2"	08
22D	0501010301	ARANDELA PLANA	08
22E	0503010027	ARANDELA PRESION 5/8"	10
22F	0503010013	TUERCA 5/8" NC	08
23	0501064690		01
24	0501064689		01
25	0501010500	TORNILLO 3/4" UNC X 3"	04
26	0503010014	TUERCA 3/4" UNC	06
27	0501010161	TORNILLO 1/2" UNC X 1.1/4"	02



Artículo	Código	Descripción	QT
28	0503010019	ARANDELA PRESION 1/2"	02
29	0511017302	ARANDELA PLANA	02
30	0501047978		01
30A	0501069169		01
30B	0501014214		01
30C	0503010751	TORNILLO 3/8" UNC X 1.1/4"	03
30D	0501010984	ARANDELA PLANA	03
30E	0503010026	TUERCA 3/8"	03
31	0511016419		02
32	0501010100	TORNILLO 5/8" UNC X 2"	06
33	0503010013	TUERCA 5/8" NC	04
34	0501041427	VARON 1.1/4" NC X 1540	01
34A	0501014250	VARON 1.1/4" X 1540	01
34B	0502012180	ARANDELA TENSORA	02
34C	0501010087	TUERCA 1.1/4" UNC 7FPP	04
35	0501041652	VARON 1.1/4" X 810 COMPL	01
35A	0501014916	VARON 1.1/4" X 810	01
35B	0501010087	TUERCA 1.1/4" UNC 7FPP	04
36	0501068213	CLAVE DOBLE 5/8 X 3/4	01
37	0501061617	CLAVE 1 CABO PLANO	01
38	0511010153	CLAVE FIXA 2.5/16	01
39	0511013888		02
40	0501067316		01
41	0501067317		01
42	0501010572	PRISIONERO 1 UNC X 1 UNS X 76	04
43	0501010574	ARANDELA PLANA	04
44	0503010340	TUERCA 1" UNF	04

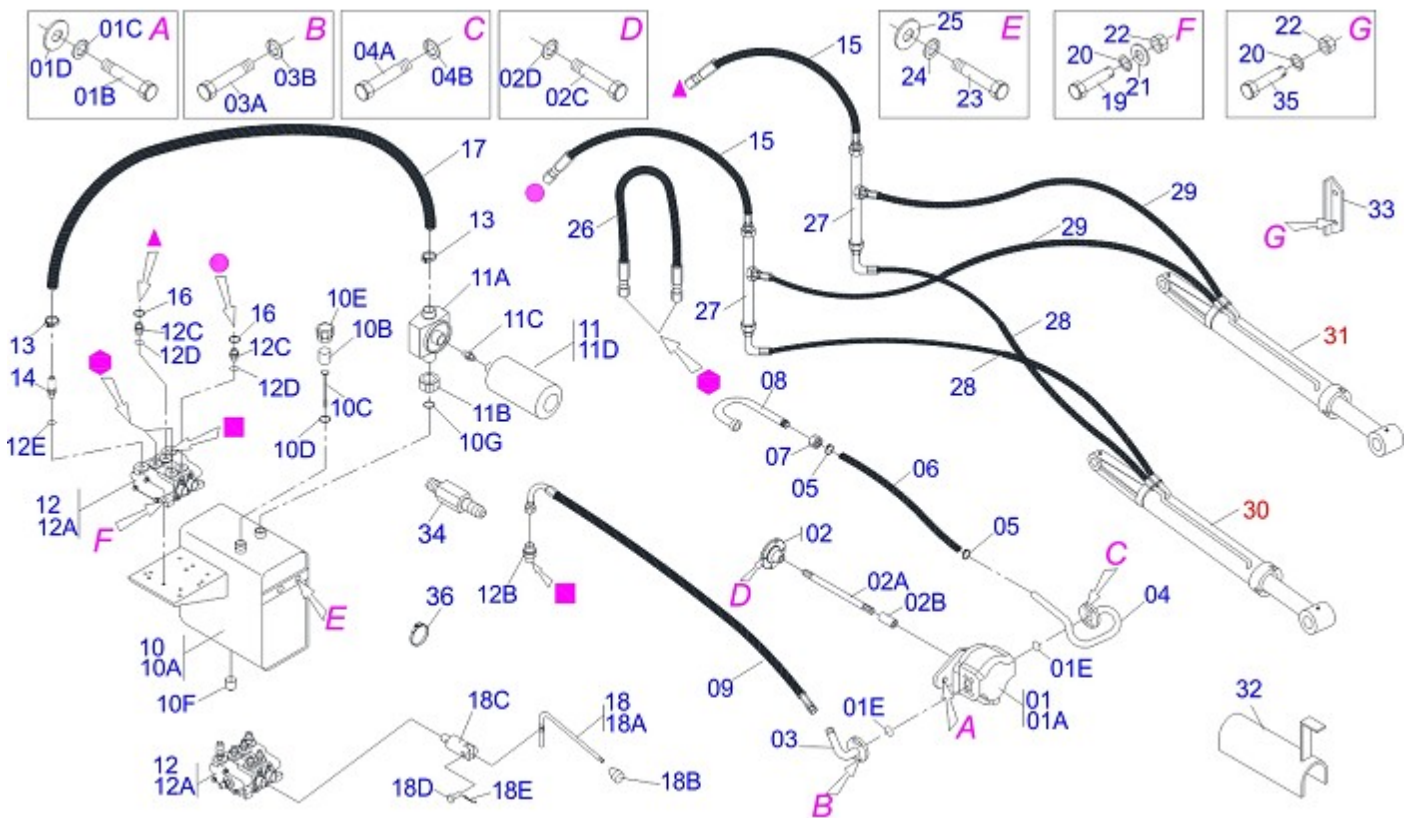

Artículo	Código	Descripción	QT
01	0501052129	BOMBA COMPLETA	01
01A	0503060045	BOMBA 40L 1/2"	01
01B	0501010080	TORNILLO 3/8" UNC X 1.1/2"	02
01C	0503010019	ARANDELA PRESION 1/2"	02
01D	0511017302	ARANDELA PLANA	02
01E	0503010173	ANILLO O'RING 2-220 N 3006-9B	02
02	0503050003	ACOPLAMIENTO	01
02A	0511064402	EJE 407 X 1.1/8 ESTR X 1.1/8-30G	01
02B	0503030838	BUJE 1.1/8" X 61 ESTR	01
03	0501069661	DUCTO PRESION BOMBA	01
03A	0503010237	TORNILLO 3/8" UNC X 1"	04
03B	0503010025	ARANDELA PRESION 3/8"	04
04	0501069536	DUCTO SUCCION BOMBA	01
04A	0503010355	TORNILLO 7/16" UNC X 1"	04
04B	0503010180	ARANDELA PRESION 7/16"	04
05	0503010243	ABRAZADERA 1.1/2" A 2"	02
06	0501010808	MANGUERA 1.1/4" X 1300 AB-AB	01
07	0501016309	TUERCA 2" UNC 16FPP X 2.5/16"	01
08	0501063383	DUCTO SALIDA TANQUE	01
09	0501080637	MANGUERA 3/4" X 2800 TR-TC	01
10	0501046828	RESERVOIR OLEO COMPLETO	01
10A	0501068067	RESERVOIR OLEO	01
10B	0503030044	ELEM FILTRANTE AR	01
10C	0501060975	MEDIDOR ACEITE	01
10D	0503010185	ANILLO O'RING 2-221 N 3006-9B	01
10E	0502020472	CUERPO TAPA TANQUE	01
10F	0503031604	TAPON 1/2 BSP	01
11	0501041108	FILTRO RETORNO MAYOR COMPL	01
11A	0502050002	CABCT FILTRO RETORNO	01
11B	0501010594	TUERCA 1" BSP S 1.5/8"	01
11C	0501010595	NIPLE 1 NF SEXT.1.1/8 X 37	01
11D	0503010183	FILTRO RETORNO	01
12	0501040873	COMANDO DOBLE 1/2"	01



CIRCUITO HIDRAULICO

Artículo	Código	Descripción	QT
12A	0503060081	COMANDO DOBLE 1/2"	01
12B	0501010589	NIPLE 1.1/16UN	01
12C	0501010590	NIPLE 7/8 NF HEX 1 X 48	04
12D	0503010045	ANILLO O'RING 2-116 N 3006-9B	04
12E	0503010602	ANILLO O'RING 2-211 N 3006-9B	02
13	0503010184	ABRAZADERA 1.1/4 A 1.1/2	02
14	0501010591	BICO P/MANGUERA	01
15	0501080014		02
16	0503010714	ANILLO O'RING 2-015 N 3006-9B	04
17	0501013822	MANGUERA 1 X 650 AB-AB	01
18	0501048023	ACCIONADOR MANDO	01
18A	0511060695	ACCIONADOR MANDO	01
18B	0503030878	MANOPLA PALANCA	01
18C	0503030347	FIJADOR SUP PALANCA (SAUER DANFOSS)	02
18D	0521010532	EJE UNION 7,93 X 23	02
18E	0503010140	PASADOR ABIERTO 1/8" X 3/4"	02
19	0501010080	TORNILLO 3/8" UNC X 1.1/2"	03
20	0503010025	ARANDELA PRESION 3/8"	07
21	0501010984	ARANDELA PLANA	03
22	0503010026	TUERCA 3/8"	07
23	0501010161	TORNILLO 1/2" UNC X 1.1/4"	02
24	0503010019	ARANDELA PRESION 1/2"	02
25	0511017302	ARANDELA PLANA	02
26	0501080120	MANGUERA 1/2 X 400 TR-TR	01
27	0501068942	CONEXION "T" NIPPLES	02
28	0501080010		02
29	0501080135		02
30	0501044368	CILINDRO HIDRAULICO 44,45 X 85,7 X 920 X 483	01
31	0501044369	CILINDRO HIDRAULICO 44,45 X 85,7 X 920 X 483	01
32	0511064563	PROTECTOR MANGUERA	01
33	0501018735	APOYO FAROL	02
34	0521014428	EXTENSION HEX	02
35	0503010134	TORNILLO 3/8" UNC X 1"	04
36	0503010246	ABRAZADERA 2" A 2.1/2" 5164	02



MARCHESAN IMPLEMENTOS E MÁQUINAS AGRÍCOLAS TATU S.A.

AV. Marchesan, 1979 - Casilla de Correos, 131 - CEP 15994-900 - Matão - SP - Brasil

Fono: +55 16.3382-8282

(FAX Venta)+55 16.3382.8297 - (Exportar) + 55 16.3382.1003

e.mail: tatu@marchesan.com.br

Home Page: www.marchesan.com.br

Redaccion e Ilustracion = GASPARI
e.mail = jgaspari@marchesan.com.br

**PIEZAS ORIGINALES
TATU**

