

CATÁLOGO DE PIEZAS

PALAS DELANTERAS

PD MF 290-4/TL SHT S-0198

Código: 0501091398



Serie: S-0198

Revisión: JANEIRO/98

PIEZAS ORIGINALES
TATU



INDICE

0909091033	PALAS DELANTERAS MF 290-4/TL SHT S-0198	1
0909091034	CIRCUITO HIDRAULICO MF 290-4	2

ATENCIÓN: **IMPORTANTE**

MARGHESAN SE RESERVA EL DERECHO DE PERFECCIONAR Y/O MODIFICAR LAS CARACTERÍSTICAS TÉCNICAS DE SUS PRODUCTOS, SIN LA OBLIGACIÓN DE PROCEDER CON LOS YA COMERCIALIZADOS Y SIN CONOCIMIENTO PREVIO DEL DISTRIBUIDOR AUTORIZADO O DEL CONSUMIDOR.

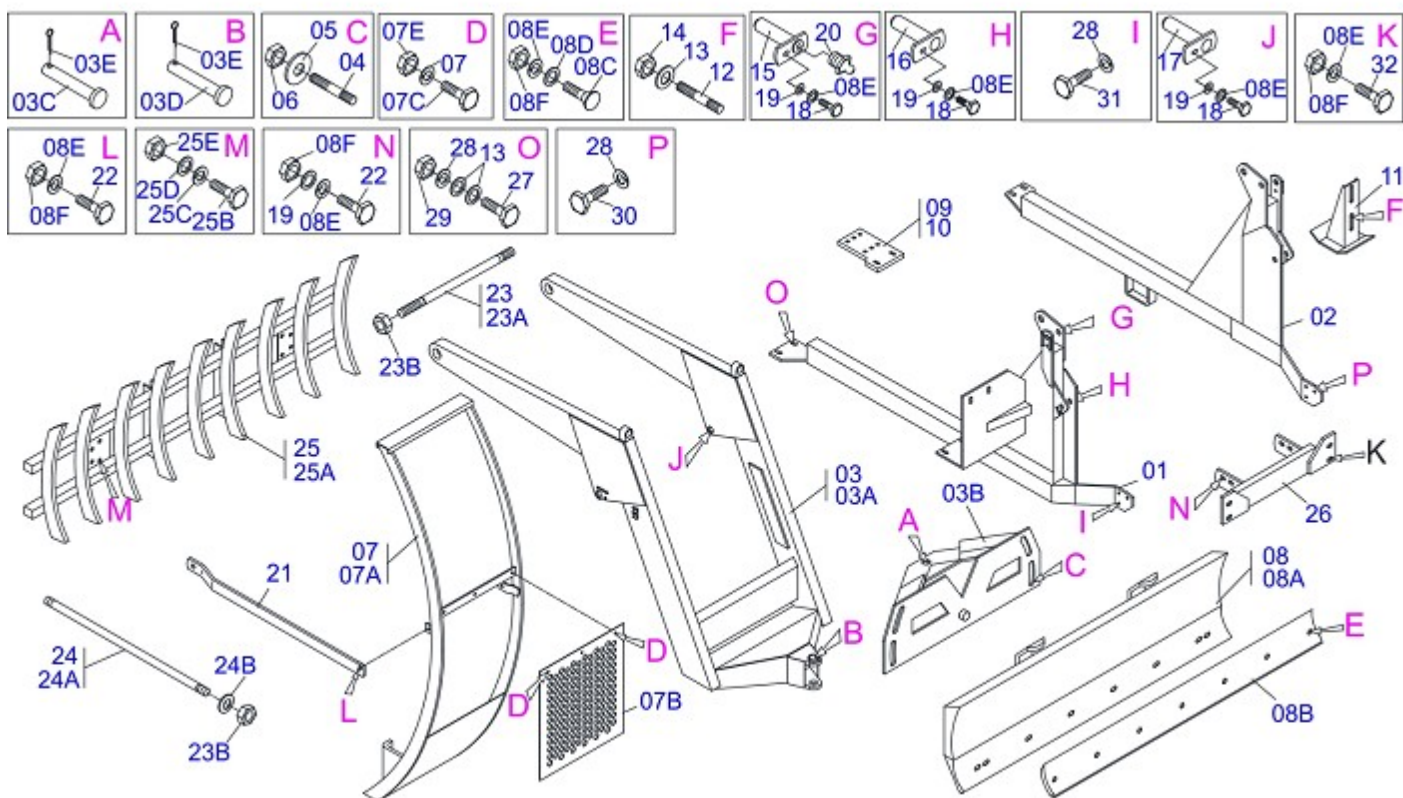

Artículo	Código	Descripción	QT
01	0501069138	CHASIS DERECHO	01
02	0501069139	CHASIS IZQUIERDO	01
03	0501047979		01
03A	0501069170		01
03B	0501062637	SOPORTE REGULACION	01
03C	0521010618	EJE UNION 37,50 X 220	01
03D	0501010612	PALANCA COMANDO	01
03E	0503010010	PASADOR ABIERTO 1/4 X 2.1/2	02
04	0501010572	PRISIONERO 1 UNC X 1 UNS X 76	04
05	0501010574	ARANDELA PLANA	04
05A	0501067999	SOPORTE CUCHILLA 2390	01
05B	0622360018	RASPADOR 940 STA-2-3	01
05C	0501012240	TORNILLO 5/8" UNC X 2.1/2"	08
05D	0501010301	ARANDELA PLANA	20
05E	0503010027	ARANDELA PRESION 5/8"	20
06	0503010340	TUERCA 1" UNF	04
07	0501047978		01
07A	0501069169		01
07B	0501014214		01
07C	0503010751	TORNILLO 3/8" UNC X 1.1/4"	03
07D	0501010984	ARANDELA PLANA	03
07E	0503010026	TUERCA 3/8"	03
08	0501047708	SOPORTE CUCHILLA 2400	01
08A	0501067999	SOPORTE CUCHILLA 2390	01
08B	0622360016	RASPADOR REVERSIBLE 2400	01
08C	0501012240	TORNILLO 5/8" UNC X 2.1/2"	08
08D	0501010301	ARANDELA PLANA	08
08E	0503010027	ARANDELA PRESION 5/8"	24
08F	0503010013	TUERCA 5/8" NC	18
09	0501064690		01
10	0501064689		01
11	0501063411	ZAPATA ESTAB	02
12	0501010571	PRISIONERO 3/4 NC X 3/4 NF X 56	04



Artículo	Código	Descripción	QT
13	0501010322	ARANDELA PLANA	12
14	0503010335	TUERCA 3/4" UNF	04
15	0501063958	EJE ARTIC TRABA 37,2 X 110	02
16	0501063959	EJE ARTICULACION CON TRABA	02
17	0501063751	EJE ARTIC 37,2 X 140	02
18	0503010962	TORNILLO 5/8" UNC X 1.1/4"	06
19	0501012140	ARANDELA PLANA	10
20	0503010002	GRASERA 1800	02
21	0511014684		02
22	0501010100	TORNILLO 5/8" UNC X 2"	06
23	0501042819	VARON 1.1/4"NC X 850	01
23A	0501018845	VARON 1./4" X 850	01
23B	0501010087	TUERCA 1.1/4" UNC 7FPP	04
24	0501041427	VARON 1.1/4" NC X 1540	02
24A	0501014250	VARON 1.1/4" X 1540	01
24B	0502012180	ARANDELA TENSORA	02
25	0108010002	HILERADOR AGR 9 DIENTES	01
25A	0501060958	DESENRAIZADOR ENLEIRADOR 9 DIENTES	01
25B	0501010276	TORNILLO 1UNC X 3"	04
25C	0501010065	ARANDELA PLANA	04
25D	0503010012	ARANDELA PRESION 1"	04
25E	0501010059	TUERCA 1" UNC 8FPP 1.5/8"	04
26	0501064510		01
27	0501010500	TORNILLO 3/4" UNC X 3"	04
28	0503010023	ARANDELA PRESION 3/4"	04
29	0503010014	TUERCA 3/4" UNC	04
30	0501010098	TORNILLO 3/4" UNC X 2"	04
31	0501010125	TORNILLO 3/4" UNC X 2.1/2"	02
32	0503010233	TORNILLO 5/8" UNC X 2.1/2"	04

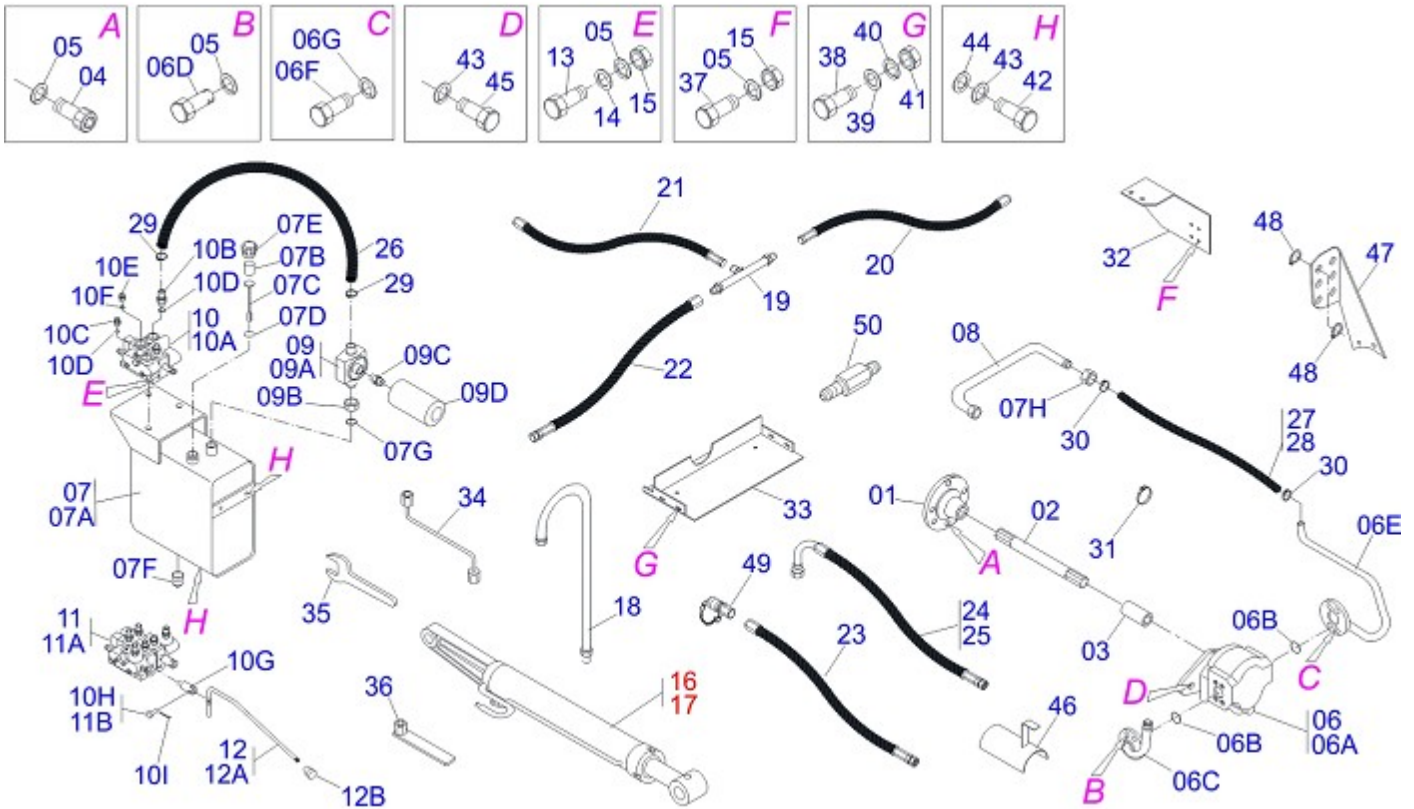

Artículo	Código	Descripción	CS	CD
01	0503050003	ACOPLAMIENTO	01	01
02	0501068938	EJE 385 X 1.1/8	01	01
03	0503030838	BUJE 1.1/8" X 61 ESTR	01	01
04	0503010175	TORNILLO 3/8" UNC X 1.1/4"	06	06
05	0503010025	ARANDELA PRESION 3/8"	17	17
06	0501052129	BOMBA COMPLETA	01	01
06A	0503060045	BOMBA 40L 1/2"	01	01
06B	0503010173	ANILLO O'RING 2-220 N 3006-9B	02	02
06C	0501069661	DUCTO PRESION BOMBA	01	01
06D	0503010237	TORNILLO 3/8" UNC X 1"	04	04
06E	0501069536	DUCTO SUCCION BOMBA	01	01
06F	0503010355	TORNILLO 7/16" UNC X 1"	04	04
06G	0503010180	ARANDELA PRESION 7/16"	04	04
07	0501047808	RESERVOIR OLEO COMPLETO	01	01
07A	0501068882	RESERVOIR OLEO	01	01
07B	0503030044	ELEM FILTRANTE AR	01	01
07C	0501060975	MEDIDOR ACEITE	01	01
07D	0503010185	ANILLO O'RING 2-221 N 3006-9B	01	01
07E	0502020472	CUERPO TAPA TANQUE	01	01
07F	0503031604	TAPON 1/2 BSP	01	01
07G	0503010046	ANILLO O'RING 2-216 N 3006-9B	01	01
07H	0501016309	TUERCA 2" UNC 16FPP X 2.5/16"	01	01
08	0501063383	DUCTO SALIDA TANQUE	01	01
09	0501041108	FILTRO RETORNO MAYOR COMPL	01	01
09A	0502050002	CABCT FILTRO RETORNO	01	01
09B	0501010594	TUERCA 1" BSP S 1.5/8"	01	01
09C	0501010595	NIPLE 1 NF SEXT.1.1/8 X 37	01	01
09D	0503010183	FILTRO RETORNO	01	01
10	0501040871	COMANDO 1/2" COMPLETO	01	
10A	0503060080	COMANDO 1/2"	01	
10B	0501010591	BICO P/MANGUERA	01	01
10C	0501010589	NIPLE 1.1/16UN	01	01
10D	0503010602	ANILLO O'RING 2-211 N 3006-9B	02	02



PD MF 290-4/TL SHT S-0198
CIRCUITO HIDRAULICO MF 290-4

Página 2
0909091034

Artículo	Código	Descripción	CS CD
10E	0501010590	NIPLE 7/8 NF HEX 1 X 48	02 04
10F	0503010045	ANILLO O'RING 2-116 N 3006-9B	02 04
10G	0503030347	FIJADOR SUP PALANCA (SAUER DANFOSS)	01 02
10H	0501010593	PASADOR 7,93 X 25 X 1/2" X 28	01
10I	0503010140	PASADOR ABIERTO 1/8" X 3/4"	01 02
11	0501040873	COMANDO DOBLE 1/2"	01
11A	0503060081	COMANDO DOBLE 1/2"	01
11B	0521010532	EJE UNION 7,93 X 23	02
12	0501047852	ACCIONADOR MANDO (PD V 118 SHT)	01 02
12A	0501069069	ACCIONADOR MANDO (V 985-4/AX 4.75)	01 01
12B	0503030878	MANOPLA PALANCA	01 01
13	0501010080	TORNILLO 3/8" UNC X 1.1/2"	01 02
14	0501010984	ARANDELA PLANA	01 02
15	0503010026	TUERCA 3/8"	01 02
16	0501044368	CILINDRO HIDRAULICO 44,45 X 85,7 X 920 X 483	01 01
17	0501044369	CILINDRO HIDRAULICO 44,45 X 85,7 X 920 X 483	01 01
18	0501064350	DUCTO PRESION COMANDO	01 01
19	0501068942	CONEXION "T" NIPPLES	02 02
20	0501080109	MANGUERA 1/2" X 800 TR-TR	02 02
21	0501080103	MANGUERA 1/2 X 1200 TR-TR	02 02
22	0501080052	MANGUERA 1/2" X 1600 TR-TR	02 02
23	0501080308		01
24	0501080402	MANGUERA 3/8 X 1700 TR-TC	01
25	0501080708		01
26	0501013822	MANGUERA 1 X 650 AB-AB	01 01
27	0501011513	MANGUERA 1.1/4" X 1100 AB-AB	01
28	0501010808	MANGUERA 1.1/4" X 1300 AB-AB	01
29	0503010184	ABRAZADERA 1.1/4 A 1.1/2	02 02
30	0503010243	ABRAZADERA 1.1/2" A 2"	02 02
31	0503010246	ABRAZADERA 2" A 2.1/2" 5164	02 02
32	0521017643	APOYO FILTRO	01 01
33	0501069729		01 01
34	0501068213	CLAVE DOBLE 5/8 X 3/4	01 01
35	0511010153	CLAVE FIXA 2.5/16	01 01
36	0501061617	CLAVE 1 CABO PLANO	01 01
37	0503010751	TORNILLO 3/8" UNC X 1.1/4"	04 04
38	0503010743	TORNILLO 1/4" UNC X 1.1/4"	04 04
39	0511017303	ARANDELA PLANA	04 04
40	0503010143	ARANDELA PRESION 1/4"	04 04
41	0503010144	TUERCA 1/4" UNC	04 04
42	0501010161	TORNILLO 1/2" UNC X 1.1/4"	04 04
43	0503010019	ARANDELA PRESION 1/2"	06 06
44	0511017302	ARANDELA PLANA	04 04
45	0503010920	TORNILLO 1/2" UNC X 1.1/2"	02 02
46	0511064563	PROTECTOR MANGUERA	01 01
47	0511019730	SOPORTE ENGANCHE RAPIDO	01
48	0503010217	ANILLO TENSOR 501040 (PARA EJE)	04
49	0501053835	HEMBRA ENGANCHE RAP 1/2 NPT	02
50	0521014428	EXTENSION HEX	02 02



MARCHESAN IMPLEMENTOS E MÁQUINAS AGRÍCOLAS TATU S.A.

AV. Marchesan, 1979 - Casilla de Correos, 131 - CEP 15994-900 - Matão - SP - Brasil

Fono: +55 16.3382-8282

(FAX Venta)+55 16.3382.8297 - (Exportar) + 55 16.3382.1003

e.mail: tatu@marchesan.com.br

Home Page: www.marchesan.com.br

Redaccion e Ilustracion = GASPARI
e.mail = jgaspari@marchesan.com.br

**PIEZAS ORIGINALES
TATU**

