

CATÁLOGO DE PIEZAS

PALAS DELANTERAS

PD MF 265 SHT S-0598

Código: 0501091396



Serie: S-0598

Revisión: MAIO/98

PIEZAS ORIGINALES
TATU



INDICE

0909091233	PALAS DELANTERAS 265 SHT S-0598	1
0909092238	CIRCUITO HIDRAULICO	2

ATENCIÓN: **IMPORTANTE**

MARGHESAN SE RESERVA EL DERECHO DE PERFECCIONAR Y/O MODIFICAR LAS CARACTERÍSTICAS TÉCNICAS DE SUS PRODUCTOS, SIN LA OBLIGACIÓN DE PROCEDER CON LOS YA COMERCIALIZADOS Y SIN CONOCIMIENTO PREVIO DEL DISTRIBUIDOR AUTORIZADO O DEL CONSUMIDOR.

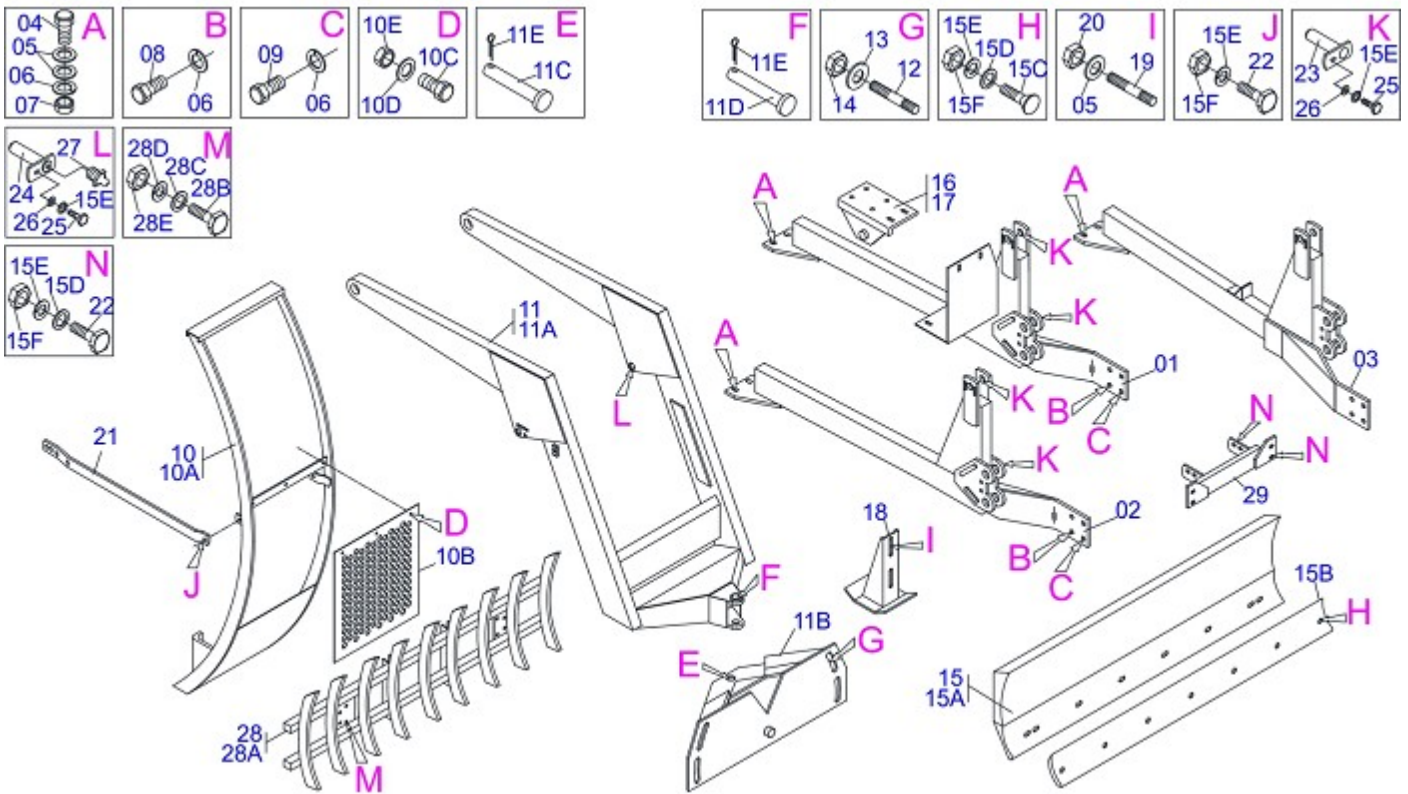

Artículo	Código	Descripción	BT SHT
01	0501063868	CHASIS DERECHO	01
02	0501063869	CHASIS DERECHO	01
03	0501063870	CHASIS IZQUIERDO	01 01
04	0501010500	TORNILLO 3/4" UNC X 3"	04 04
05	0501010322	ARANDELA PLANA	12 12
06	0503010023	ARANDELA PRESION 3/4"	12 12
07	0503010014	TUERCA 3/4" UNC	04 04
08	0501010098	TORNILLO 3/4" UNC X 2"	06 06
09	0501010125	TORNILLO 3/4" UNC X 2.1/2"	02 02
10	0501040970	GUIA SOPORTE MOVIL COMPL	01 01
10A	0501063161	GUIA SOPORTE MOVIL COMPL	01 01
10B	0501014213	PROTECCIÓN DELANTERA	01 01
10C	0503010751	TORNILLO 3/8" UNC X 1.1/4"	03 03
10D	0501010984	ARANDELA PLANA	03 03
10E	0503010026	TUERCA 3/8"	03 03
11	0501042506		01 01
11A	0501063720		01 01
11B	0501063368	SOPORTE REGULACION	01 01
11C	0521010618	EJE UNION 37,50 X 220	01 01
11D	0521010612	EJE UNION 37,50 X 90	01 01
11E	0503010010	PASADOR ABIERTO 1/4 X 2.1/2	02 02
12	0501010572	PRISIONERO 1 UNC X 1 UNS X 76	04 04
13	0501010574	ARANDELA PLANA	04 04
14	0503010340	TUERCA 1" UNF	04 04
15	0501047707	SOPORTE CUCHILLA 2000	01 01
15A	0501067998	SOPORTE CUCHILLA 1990	01 01
15B	0622360015	RASPADOR REVERSIBLE 2000	07 07
15C	0501012240	TORNILLO 5/8" UNC X 2.1/2"	07 07
15D	0501010301	ARANDELA PLANA	07 07
15E	0503010027	ARANDELA PRESION 5/8"	07 07
15F	0503010013	TUERCA 5/8" NC	07 07
16	0501064889		01 01
17	0501064690		01 01



PD MF 265 SHT S-0598
PALAS DELANTERAS 265 SHT S-0598

Página 1
0909091233

Artículo	Código	Descripción	BT SHT
18	0501063411	ZAPATA ESTAB	01 01
19	0501010571	PRISIONERO 3/4 NC X 3/4 NF X 56	04 04
20	0503010335	TUERCA 3/4" UNF	04 04
21	0501018838		02 02
22	0501010100	TORNILLO 5/8" UNC X 2"	10 10
23	0501063958	EJE ARTIC TRABA 37,2 X 110	04 04
24	0501063960	EJE ARTIC TRABA 37,2 X 130	02 02
25	0503010962	TORNILLO 5/8" UNC X 1.1/4"	06 06
26	0501012140	ARANDELA PLANA	16 16
27	0503010002	GRASERA 1800	02 02
28	0108010002	HILERADOR AGR 9 DIENTES	02 02
28A	0501060958	DESENRAIZADOR ENLEIRADOR 9 DIENTES	01 01
28B	0501010276	TORNILLO 1UNC X 3"	04 04
28C	0501010623	ARANDELA PLANA	04 04
28D	0503010012	ARANDELA PRESION 1"	04 04
28E	0501010059	TUERCA 1" UNC 8FPP 1.5/8"	04 04
29	0501062883		01 01

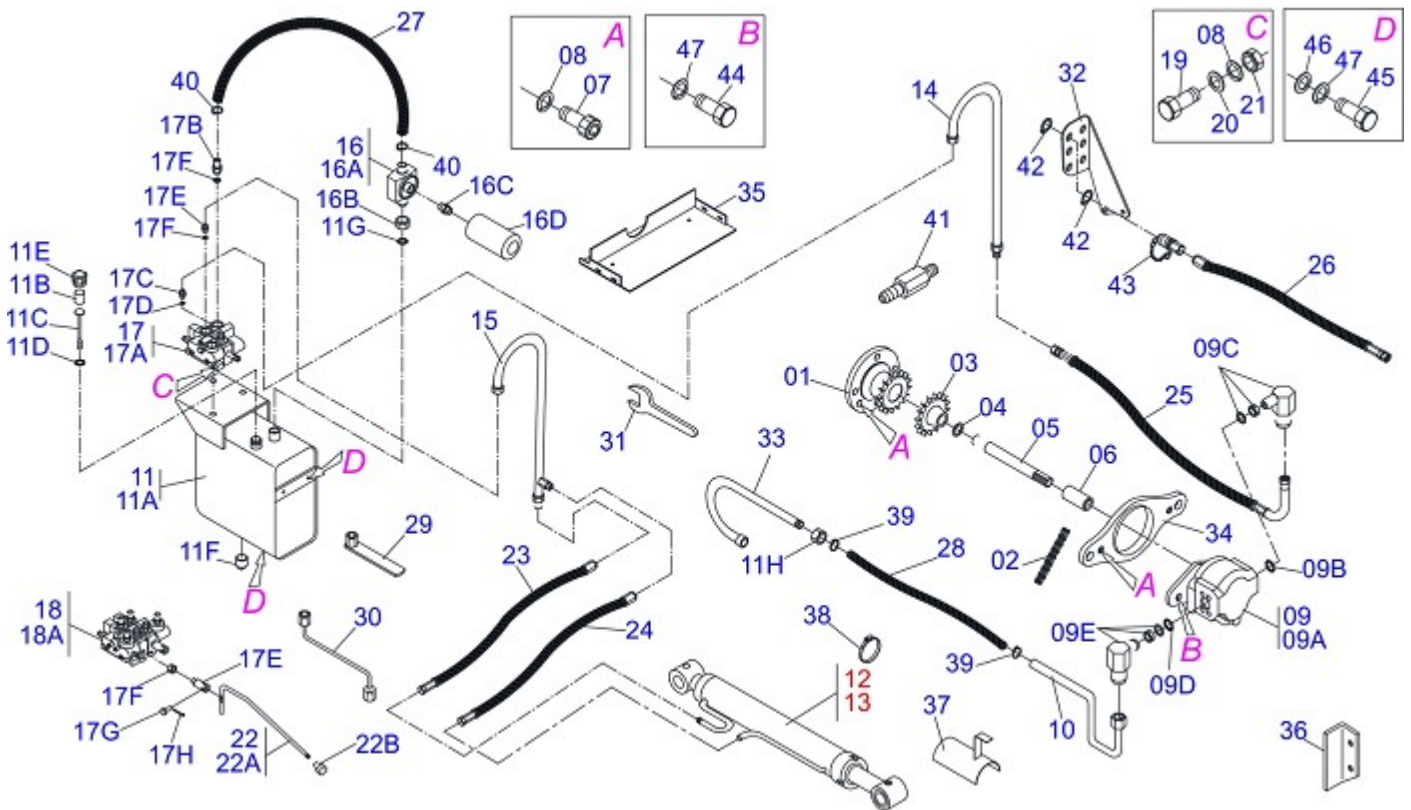

Artículo	Código	Descripción	CS	CD
01	0503050010	BRIDA RUEDA DENTADA	01	01
02	0503010455	CADENA 50-2 X 15 ESLABON + ENMIENDA	01	01
03	0503050075	ENGRANAJE 16Z	01	01
04	0501010890	ARANDELA APOYO	01	01
05	0503030130	EJE 370 X R7/8 UNC X 7/8 ESTRIADO	01	01
06	0503030043	BUJE 61	01	01
07	0503010751	TORNILLO 3/8" UNC X 1.1/4"	04	04
08	0503010025	ARANDELA PRESION 3/8"	07	07
09	0501052223	BOMBA 20L C/DUTO/COTOVELO MF S0498	01	01
09A	0503060074	BOMBA 20L 3/8" ENT 7/8"	01	01
09B	0503011109	ANILLO O'RING 2-119 N 3006-9B	01	01
09C	0503012149	CONECTOR CARVO	01	01
09D	0503010190	ANILLO O'RING 2-114 N 3006-9B	01	01
09E	0503012148	CONECTOR CURVO	01	01
10	0511060350	DUCTO SUCCION BOMBA	01	01
11	0501047808	RESERVOIR OLEO COMPLETO	01	01
11A	0501068882	RESERVOIR OLEO	01	01
11B	0503030044	ELEM FILTRANTE AR	01	01
11C	0501060975	MEDIDOR ACEITE	01	01
11D	0503010185	ANILLO O'RING 2-221 N 3006-9B	01	01
11E	0502020472	CUERPO TAPA TANQUE	01	01
11F	0503031604	TAPON 1/2 BSP	01	01
11G	0503010046	ANILLO O'RING 2-216 N 3006-9B	01	01
11H	0501016309	TUERCA 2" UNC 16FPP X 2.5/16"	01	01
12	0501040951	CILINDRO HIDRAULICO 38,1 X 63,5 X 756 X 487 BBD	01	01
13	0501040952	CILINDRO HIDRAULICO 38,1 X 63,5 X 756 X 487 BBE	01	01
14	0501064407	DUCTO PRESION COMANDO	01	01
15	0501064408	TUBO DISTRIBUIDOR ACEITE	02	02
16	0501040959	FILTRO RETORNO MENOR COMPL	01	01
16A	0502050002	CABCT FILTRO RETORNO	01	01
16B	0501010594	TUERCA 1" BSP S 1.5/8"	01	01
16C	0501010595	NIPLE 1 NF SEXT.1.1/8 X 37	01	01
16D	0503010545	FILTRO RETORNO	01	01



PD MF 265 SHT S-0598
CIRCUITO HIDRAULICO

Página 2
0909092238

Artículo	Código	Descripción	CS CD
17	0501040976	COMANDO 3/8"	01
17A	0503060078	COMANDO 3/8"	01
17B	0501011806	BICO P/MANGUERA 1"	01 01
17C	0501010590	NIPLA 7/8 NF HEX 1 X 48	03 05
17D	0503010045	ANILLO O'RING 2-116 N 3006-9B	04 06
17E	0503011050	FIJADOR INF PALANCA	01 02
17F	0503010337	TUERCA 5/16" UNC	01 02
17G	0521010532	EJE UNION 7,93 X 23	01 02
17H	0503010140	PASADOR ABIERTO 1/8" X 3/4"	01 02
18	0501041024	COMANDO DOBLE 3/8"	01
18A	0503060079	COMANDO DOBLE 3/8"	01
19	0501010080	TORNILLO 3/8" UNC X 1.1/2"	03 03
20	0501010984	ARANDELA PLANA	03 03
21	0503010026	TUERCA 3/8"	03 03
22	0511040565	ACCIONADOR MANDO	01 02
22A	0511066395	PALANCA COMANDO	01 01
22B	0503030878	MANOPLA PALANCA	01 01
23	0501080128	MANGUERA 3/8 X 1800 TR-TR	02 02
24	0501080321	MANGUERA 3/8 X 1200 TR-TR	02 02
25	0501080336	MANG 1/2" X 2450 TR-TR	01 01
26	0501080245		02
27	0501013822	MANGUERA 1 X 650 AB-AB	01 01
28	0501013436		01 01
29	0501061617	CLAVE 1 CABO PLANO	01 01
30	0501068213	CLAVE DOBLE 5/8 X 3/4	01 01
31	0511010153	CLAVE FIXA 2.5/16	01 01
32	0511019730	SOPORTE ENGANCHE RAPIDO	01
33	0501063388	DUCTO SALIDA TANQUE	01 01
34	0502020182		01 01
35	0501069729		01 01
36	0501018735	APOYO FAROL	02 02
37	0511064563	PROTECTOR MANGUERA	01 01
38	0503010246	ABRAZADERA 2" A 2.1/2" 5164	03 03
39	0503010243	ABRAZADERA 1.1/2" A 2"	02 02
40	0503010184	ABRAZADERA 1.1/4 A 1.1/2	02 04
41	0521014428	EXTENSION HEX	02
42	0503010217	ANILLO TENSOR 501040 (PARA EJE)	04
43	0501053835	HEMBRA ENGANCHE RAP 1/2 NPT	02
44	0503010920	TORNILLO 1/2" UNC X 1.1/2"	02 02
45	0501010161	TORNILLO 1/2" UNC X 1.1/4"	04 04
46	0511017302	ARANDELA PLANA	04 04
47	0503010019	ARANDELA PRESION 1/2"	04 04



MARCHESAN IMPLEMENTOS E MÁQUINAS AGRÍCOLAS TATU S.A.

AV. Marchesan, 1979 - Casilla de Correos, 131 - CEP 15994-900 - Matão - SP - Brasil

Fono: +55 16.3382-8282

(FAX Venta)+55 16.3382.8297 - (Exportar) + 55 16.3382.1003

e.mail: tatu@marchesan.com.br

Home Page: www.marchesan.com.br

Redaccion e Ilustracion = GASPARI
e.mail = jgaspari@marchesan.com.br

**PIEZAS ORIGINALES
TATU**

