

# CATÁLOGO DE PIEZAS

## PALAS DELANTERAS

PD MF 295-4 S-1188

Código: 0501091389



Serie: S-1188

Revisión: NOVIEMBRE/88

PIEZAS ORIGINALES  
TATU



# INDICE

0909091243	CARGADORAS DELANTERAS MF 295-4 S-1188	.....	1
0909091244	CIRCUITO HIDRAULICO	.....	2
0909091245	CILINDRO HIDRAULICO	.....	3

## ATENCIÓN: **IMPORTANTE**

MARGHESAN SE RESERVA EL DERECHO DE PERFECCIONAR Y/O MODIFICAR LAS CARACTERÍSTICAS TÉCNICAS DE SUS PRODUCTOS, SIN LA OBLIGACIÓN DE PROCEDER CON LOS YA COMERCIALIZADOS Y SIN CONOCIMIENTO PREVIO DEL DISTRIBUIDOR AUTORIZADO O DEL CONSUMIDOR.

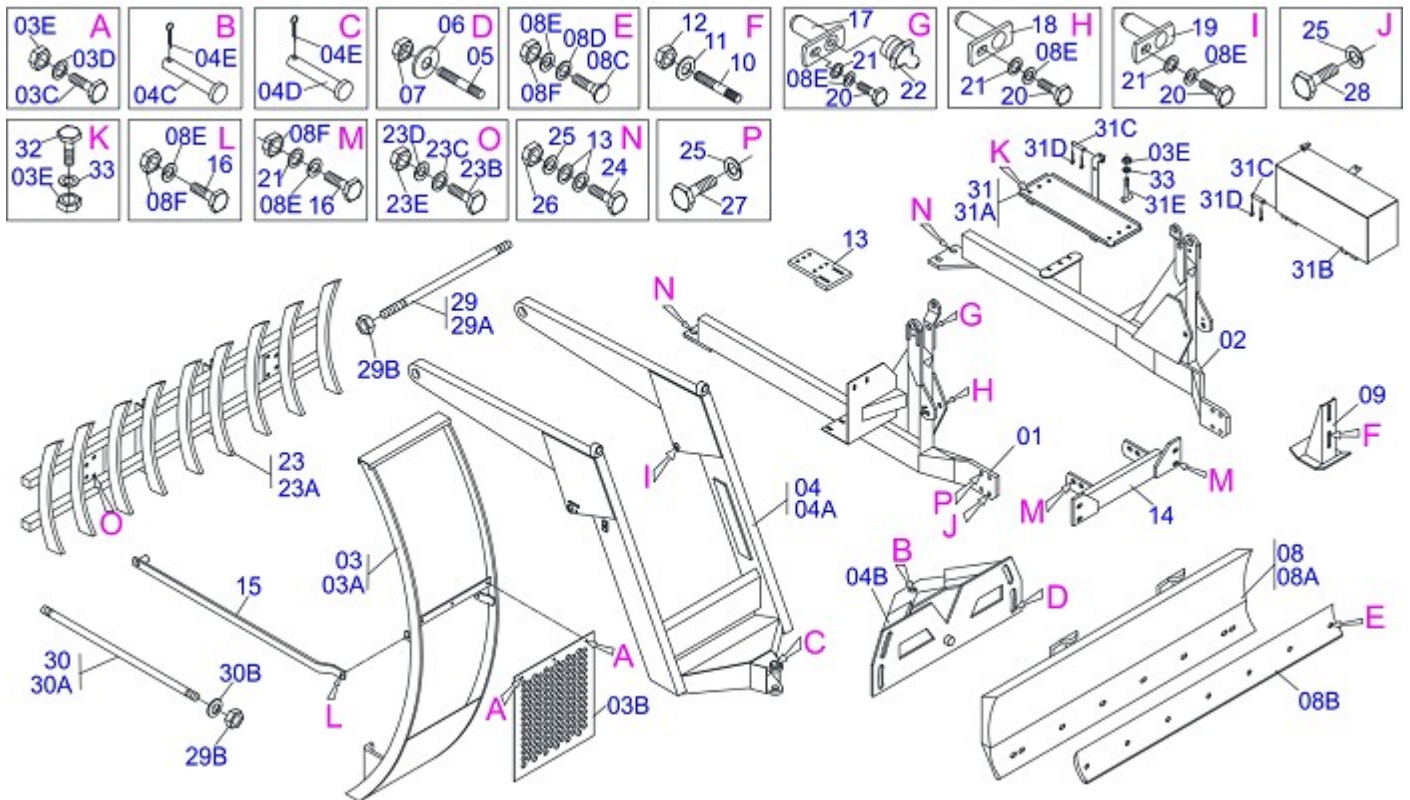

Artículo	Código	Descripción	QT
01	0501063889	CHASIS DERECHO	01
02	0501063890	CHASIS IZQUIERDO	01
03	0501047978		01
03A	0501069169		01
03B	0501014214		01
03C	0503010751	TORNILLO 3/8" UNC X 1.1/4"	03
03D	0501010984	ARANDELA PLANA	03
03E	0503010026	TUERCA 3/8"	04
04	0501042513		01
04A	0501063701		01
04B	0501062637	SOPORTE REGULACION	01
04C	0521010618	EJE UNION 37,50 X 220	01
04D	0521010612	EJE UNION 37,50 X 90	01
04E	0503010010	PASADOR ABIERTO 1/4 X 2.1/2	02
05	0501010572	PRISIONERO 1 UNC X 1 UNS X 76	04
06	0501010574	ARANDELA PLANA	04
07	0503010340	TUERCA 1" UNF	04
08	0501047710	SOPORTE CUCHILLA 2600 COMPL	01
08A	0501068001	SOPORTE CUCHILLA 2590	01
08B	0622360011	RASPADOR REVERSIBLE 2400	01
08C	0501012240	TORNILLO 5/8" UNC X 2.1/2"	07
08D	0501010301	ARANDELA PLANA	07
08E	0503010027	ARANDELA PRESION 5/8"	23
08F	0503010013	TUERCA 5/8" NC	17
09	0501063411	ZAPATA ESTAB	01
10	0501010571	PRISIONERO 3/4 NC X 3/4 NF X 56	04
11	0501010322	ARANDELA PLANA	12
12	0503010335	TUERCA 3/4" UNF	04
13	0501014778	ZAPATA CHASIS DER	02
14	0501062883		01
15	0501062748		02
16	0501010100	TORNILLO 5/8" UNC X 2"	10
17	0501063751	EJE ARTIC 37,2 X 140	02



## CARGADORAS DELANTERAS MF 295-4 S-1188

0909091243

Artículo	Código	Descripción	QT
18	0501063444	EJE ARTICULACION CON TRABA	02
19	0501063446	EJE ARTICULACION CON TRABA	02
20	0503010962	TORNILLO 5/8" UNC X 1.1/4"	06
21	0501012140	ARANDELA PLANA	14
22	0503010002	GRASERA 1800	02
23	0108010002	HILERADOR AGR 9 DIENTES	02
23A	0501060958	DESENRAIZADOR ENLEIRADOR 9 DIENTES	01
23B	0501010276	TORNILLO 1UNC X 3"	04
23C	0501010623	ARANDELA PLANA	04
23D	0503010012	ARANDELA PRESION 1"	04
23E	0501010059	TUERCA 1" UNC 8FPP 1.5/8"	04
24	0501010125	TORNILLO 3/4" UNC X 2.1/2"	04
25	0503010023	ARANDELA PRESION 3/4"	12
26	0503010014	TUERCA 3/4" UNC	04
27	0501010098	TORNILLO 3/4" UNC X 2"	06
28	0503010797	TORNILLO 3/4" UNC X 4"	02
29	0501040954	VARON 1.1/4" NC X 760	01
29A	0501010628	VARON 1.1/4" X 760	01
29B	0501010087	TUERCA 1.1/4" UNC 7FPP	10
30	0501041856	VARON 1.1/4" NC X 1430	02
30A	0501014855	VARON 1.1/4" X 1430	01
30B	0502012180	ARANDELA TENSORA	02
31	0501041485	CAJA BATERIA	01
31A	0501061298	BASE SUPERIOR SOPORTE	01
31B	0501061299		01
31C	0501010828	EJE ARTICULACION	03
31D	0503010140	PASADOR ABIERTO 1/8" X 3/4"	06
31E	0501061300	FIJADOR TAPA	01
32	0501010080	TORNILLO 3/8" UNC X 1.1/2"	04
33	0503010025	ARANDELA PRESION 3/8"	05



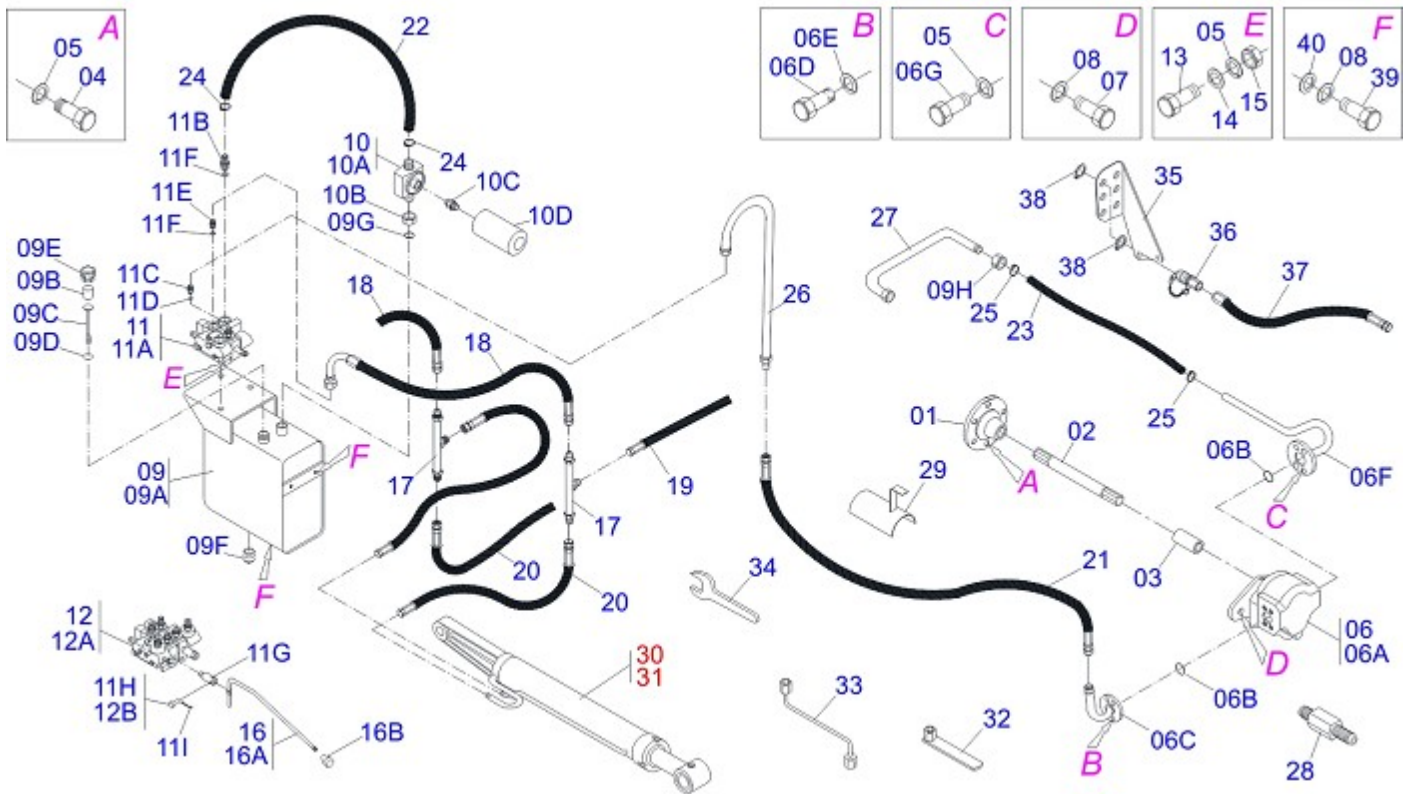

Artículo	Código	Descripción	CS	CD
01	0503050005		01	01
02	0501068907	EJE 340 X 7/8 ESTR X 1.1/8	01	01
03	0503030046		01	01
04	0503010207	TORNILLO 3/8" UN X 1"	06	06
05	0503010025	ARANDELA PRESION 3/8"	13	13
06	0501041484	BOMBA ENGRANAJE COMPLETA	01	01
06A	0503060045	BOMBA 40L 1/2"	01	01
06B	0503010173	ANILLO O'RING 2-220 N 3006-9B	02	02
06C	0501061313	DUCTO SUCCION BOMBA	01	01
06D	0501011179	TORNILLO 7/16" UNC X 1"	04	04
06E	0503010180	ARANDELA PRESION 7/16"	04	04
06F	0501061315	DUCTO PRESION BOMBA	01	01
06G	0501010112	TORNILLO 3/8" UNC X 1"	04	04
07	0503010740	TORNILLO 1/2" UNC X 2"	02	02
08	0503010019	ARANDELA PRESION 1/2"	06	06
09	0501047808	RESERVOIR OLEO COMPLETO	01	01
09A	0501068882	RESERVOIR OLEO	01	01
09B	0503030044	ELEM FILTRANTE AR	01	01
09C	0501060975	MEDIDOR ACEITE	01	01
09D	0503010185	ANILLO O'RING 2-221 N 3006-9B	01	01
09E	0502020472	CUERPO TAPA TANQUE	01	01
09F	0503031604	TAPON 1/2 BSP	01	01
09G	0503010046	ANILLO O'RING 2-216 N 3006-9B	01	01
09H	0501016309	TUERCA 2" UNC 16FPP X 2.5/16"	01	01
10	0501041108	FILTRO RETORNO MAYOR COMPL	01	01
10A	0502050002	CABCT FILTRO RETORNO	01	01
10B	0501010594	TUERCA 1" BSP S 1.5/8"	01	01
10C	0501010595	NIPLA 1 NF SEXT.1.1/8 X 37	01	01
10D	0503010183	FILTRO RETORNO	01	01
11	0501040871	COMANDO 1/2" COMPLETO	01	
11A	0503060080	COMANDO 1/2"	01	
11B	0501010591	BICO P/MANGUERA	01	01
11C	0501010589	NIPLA 1.1/16UN	01	01



Artículo	Código	Descripción	CS	CD
11D	0503010602	ANILLO O'RING 2-211 N 3006-9B	02	02
11E	0501010590	NIPLE 7/8 NF HEX 1 X 48	02	04
11F	0503010045	ANILLO O'RING 2-116 N 3006-9B	02	04
11G	0503030347	FIJADOR SUP PALANCA (SAUER DANFOSS)	01	02
11H	0501010593	PASADOR 7,93 X 25 X 1/2" X 28	01	
11I	0503010140	PASADOR ABIERTO 1/8" X 3/4"	01	02
12	0501040873	COMANDO DOBLE 1/2"	01	
12A	0503060081	COMANDO DOBLE 1/2"	01	
12B	0521010532	EJE UNION 7,93 X 23	02	
13	0501010080	TORNILLO 3/8" UNC X 1.1/2"	03	03
14	0501010984	ARANDELA PLANA	03	03
15	0503010026	TUERCA 3/8"	03	03
16	0501041196	PALANCA COMANDO COMPL.	02	02
16A	0501067556	ACCIONADOR MANDO ( V-985-4)	01	01
16B	0503030878	MANOPLA PALANCA	01	01
17	0501068942	CONEXION "T" NIPPLES	01	01
18	0501080093	MANGUERA 1/2 X 1300 TR-TC	02	02
19	0501080346	MANGUERA 1/2" X 2000 TR-TR	02	02
20	0501080035	MANGUERA 1/2" X 900 TR-TR	02	02
21	0501080247		01	01
22	0501013822	MANGUERA 1 X 650 AB-AB	01	01
23	0501010835		01	01
24	0503010184	ABRAZADERA 1.1/4 A 1.1/2	02	02
25	0503010243	ABRAZADERA 1.1/2" A 2"	02	02
26	0501063082	DUCTO PRESION COMANDO	01	01
27	0501063383	DUCTO SALIDA TANQUE	01	01
28	0521014428	EXTENSION HEX	02	02
29	0511064563	PROTECTOR MANGUERA	01	01
30	0501044598	CILINDRO HIDRAULICO 44,45 X 85,7 X 900 X 483	01	01
31	0501044599	CILINDRO HIDRAULICO 44,45 X 85,7 X 900 X 483	01	01
32	0501061617	CLAVE 1 CABO PLANO	01	01
33	0501068213	CLAVE DOBLE 5/8 X 3/4	01	01
34	0511010153	CLAVE FIXA 2.5/16	01	01
35	0511019730	SOPORTE ENGANCHE RAPIDO	01	
36	0503010186		02	
37	0501080075	MANGUERA 1/2 X 2400 TR-TM	02	
38	0503010217	ANILLO TENSOR 501040 (PARA EJE)	04	
39	0501010161	TORNILLO 1/2" UNC X 1.1/4"	04	04
40	0511017302	ARANDELA PLANA	04	04

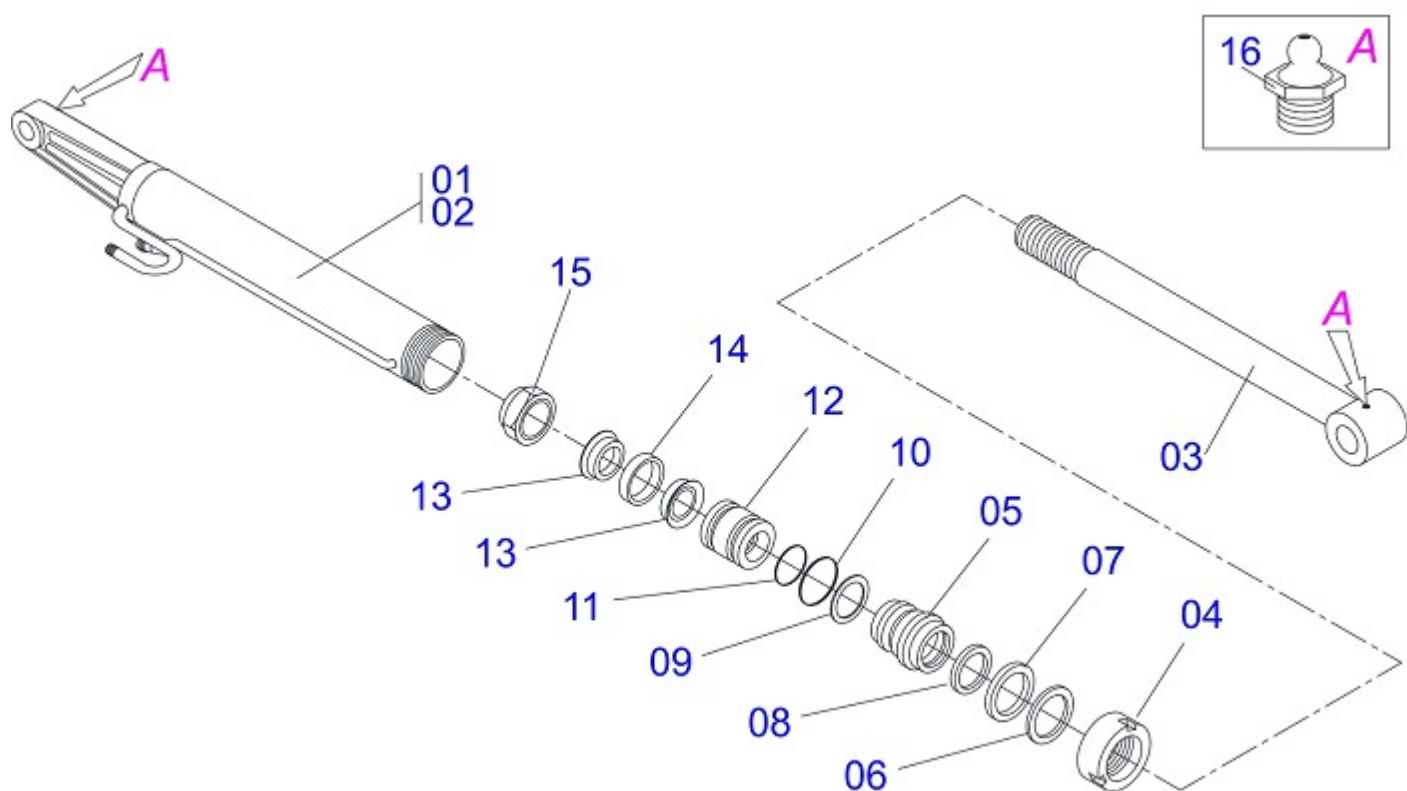

Artículo	Código	Descripción	QT
00	0501044598	CILINDRO HIDRAULICO 44,45 X 85,7 X 900 X 483	01
00A	0501044599	CILINDRO HIDRAULICO 44,45 X 85,7 X 900 X 483	01
01	0501063606	CAMISA 85,7 X 483 DER	01
02	0501063607	CAMISA 85,7 X 483 IZQ	01
03	0511062168	EXTENSOR 44,45 X 628	01
04	0502010993	TAPA MOVIL 85,72	01
05	0502010781	SOPORTE ANILLOS 44,45 X 85,72	01
06	0503010761	ANILLO RASCADOR D-1750	01
07	0503010990	ANILLO 1870-1750-375-B	01
08	0503010949	ANILLO GUIA INTERNO W2-2000-500	01
09	0503011060	ANILLO BACK-UP 8-336	01
10	0503010976	ANILLO O'RING 2-336 N 3006-9B	01
11	0503010042	ANILLO O'RING 2-214 N 3006-9B	01
12	0502010843	EMBOLO 44,45 X 85,7	01
13	0503010170	ANILLO 3120 2750	02
14	0503010948	ANILLO GUIA EXTERNO W4-3346-590	01
15	0503010063	TUERCA 1" UNF	01
16	0503010002	GRASERA 1800	02







**MARCHESAN IMPLEMENTOS E MÁQUINAS AGRÍCOLAS TATU S.A.**

AV. Marchesan, 1979 - Casilla de Correos, 131 - CEP 15994-900 - Matão - SP - Brasil

Fono: +55 16.3382-8282

(FAX Venta)+55 16.3382.8297 - (Exportar) + 55 16.3382.1003

e.mail: [tatu@marchesan.com.br](mailto:tatu@marchesan.com.br)

Home Page: [www.marchesan.com.br](http://www.marchesan.com.br)

*Redaccion e Ilustracion = GASPARI*  
*e.mail = [jgaspari@marchesan.com.br](mailto:jgaspari@marchesan.com.br)*

**PIEZAS ORIGINALES  
TATU**

