

CATÁLOGO DE PIEZAS

PD - PALAS DELANTERAS

PD MF 265-4

Código: 0501091386



Serie: S-1188

Revisión: NOVIEMBRE/1988

PIEZAS ORIGINALES
TATU



PRODUCTOS

Código	Descripción
0106030144	PD MF 265-4 SHT CD S-1088
0106030184	PD MF 265-4 SHT CD SL S-1088
0106030143	PD MF 265-4 SHT CS

ATENCIÓN: **IMPORTANTE**

MARCHESAN S/A SE RESERVA EL DERECHO DE PERFECCIONAR Y/O MODIFICAR LAS CARACTERÍSTICAS TÉCNICAS DE SUS PRODUCTOS, SIN LA OBLIGACIÓN DE PROCEDER CON LOS YA COMERCIALIZADOS Y SIN CONOCIMIENTO PREVIO DEL DISTRIBUIDOR AUTORIZADO O DEL CONSUMIDOR.

INDICE

0909092236	PALAS DELANTERAS MF 265-4 S-1188	1
0909092237	CIRCUITO HIDRAULICO	2
0909090247	CILINDRO HIDRAULICO	3
0909091238	CILINDRO HIDRÁULICO	4

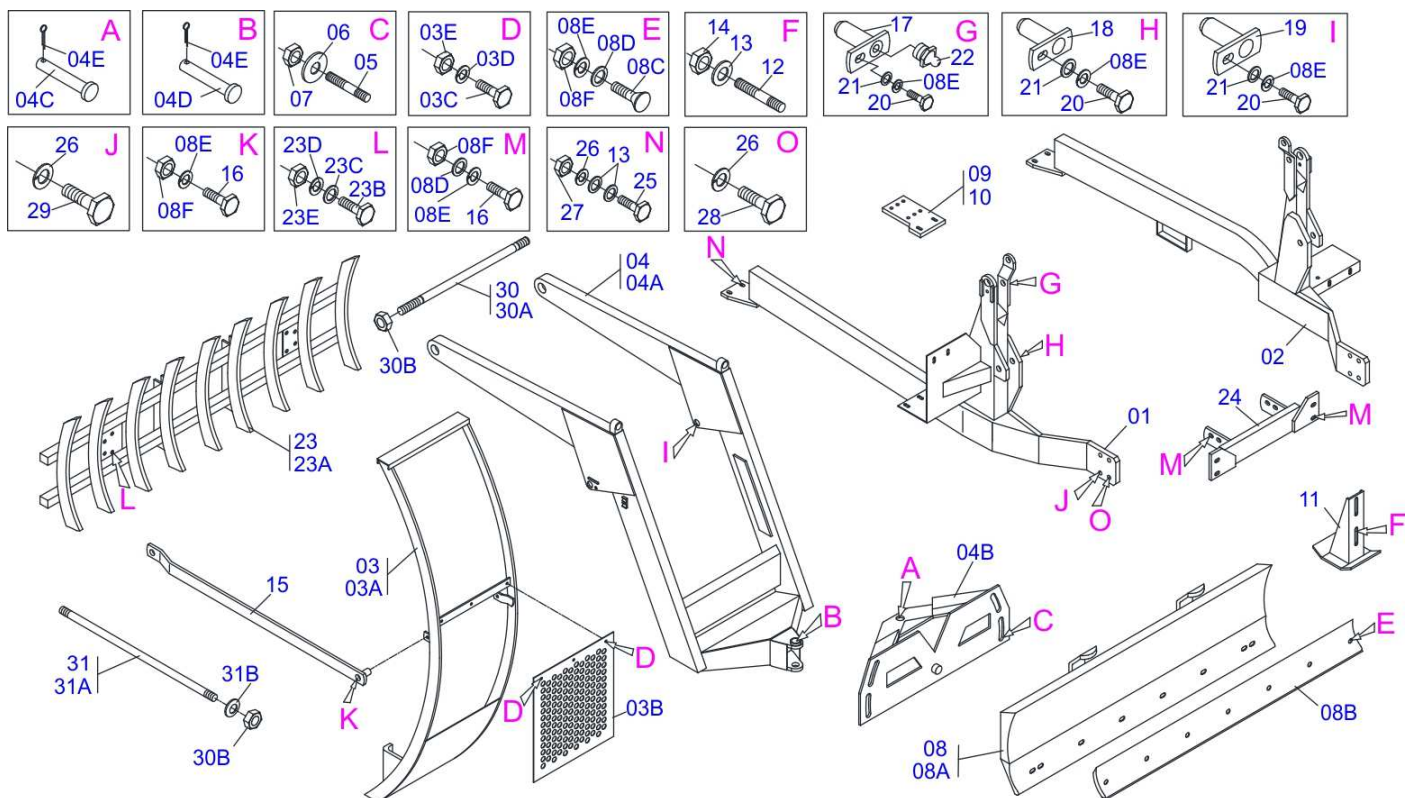

Artículo	Código	Descripción	QT
01	0501064347	CHASIS DERECHO	01
02	0501064348	CHASIS IZQUIERDO	01
03	0501047978	GUIA SOPORTE	01
03A	0501069169	GUIA SOPORTE MOVIL	01
03B	0501014214	PROTECCIÓN DELANTERA	01
03C	0503010751	TORNILLO 3/8" UNC X 1.1/4"	03
03D	0501010984	ARANDELA PLANA	03
03E	0503010026	TUERCA 3/8	03
04	0501042513	GUIA SOPORTE MOVIL COMPL	01
04A	0501063701	SOPORTE MOVIL	01
04B	0501062637	SOPORTE REGULACION	01
04C	0521010618	EJE UNION 37,50 X 220	01
04D	0521010612	EJE UNION 37,50 X 90	01
04E	0503010010	PASADOR ABIERTO 1/4 X 2.1/2	02
05	0501010572	ESPARRAGO 1"UNC X 1"UNS X 73	04
06	0501010574	ARANDELA PLANA	04
07	0503010340	TUERCA 1	04
08	0501047708	SOPORTE CUCHILLA 2400	01
08A	0501067999	SOPORTE CUCHILLA 2390	01
08B	0622360016	RASPADOR REVERSIBLE 2400	01
08C	0501012240	TORNILLO 5/8" UNC X 2.1/2"	07
08D	0501010301	ARANDELA PLANA	07
08E	0503010027	ARANDELA PRESION	23
08F	0503010013	TUERCA 5/8	17
09	0501061689	DUCTO PRESION COMANDO	01
10	0501064690	ZAPATA CHASIS DER	01
11	0501063411	ZAPATA ESTAB	02
12	0501010571	ESPARRAGO 3/4 NC X 3/4 NF X 56	04
13	0501010322	ARANDELA PLANA 20.50 X 46 X 4.75	12
14	0503010335	TUERCA 3/4	04
15	0501062748	BARRA LIGACION	02
16	0501010100	TORNILLO 5/8 UNC X 2 C S G.5	10
17	0501063958	EJE ARTIC TRABA 37,2 X 110	02



Artículo	Código	Descripción	QT
18	0501063959	EJE ARTICULACION CON TRABA	02
19	0501063751	EJE ARTIC 37,2 X 140	02
20	0503010962	TORNILLO 5/8" UNC X 1.1/4"	06
21	0501012140	ARANDELA PLANA	14
22	0503010002	GRASERA 1800	02
23	0108010002	HILERADOR AGR 9 DIENTES	02
23A	0501060958	DESENRAIZADOR ENLEIRADOR 9 DIENTES	01
23B	0501010276	TORNILLO 1UNC X 3	04
23C	0501010623	ARANDELA PLANA	04
23D	0503010012	ARANDELA PRESION 1"	04
23E	0501010059	TUERCA 1.5/8	04
24	0501064510	SOPORTE GUIA	01
25	0501010500	TORNILLO 3/4"UNC X3"	04
26	0503010023	ARANDELA PRESION	12
27	0503010014	TUERCA 3/4" UNC	04
28	0501010098	TORNILLO 3/4 UNC X 2	06
29	0503010797	TORNILLO 3/4" UNC X 4"	02
30	0501040954	VARON 1.1/4" NC X 760	01
30A	0501010628	VARON 1.1/4" X 760	01
30B	0501010087	TUERCA 1.1/4"	08
31	0501041856	VARON 1.1/4" NC X 1430	02
31A	0501014855	VARON 1.1/4" X 1430	01
31B	0502012180	ARANDELA TENSORA	02

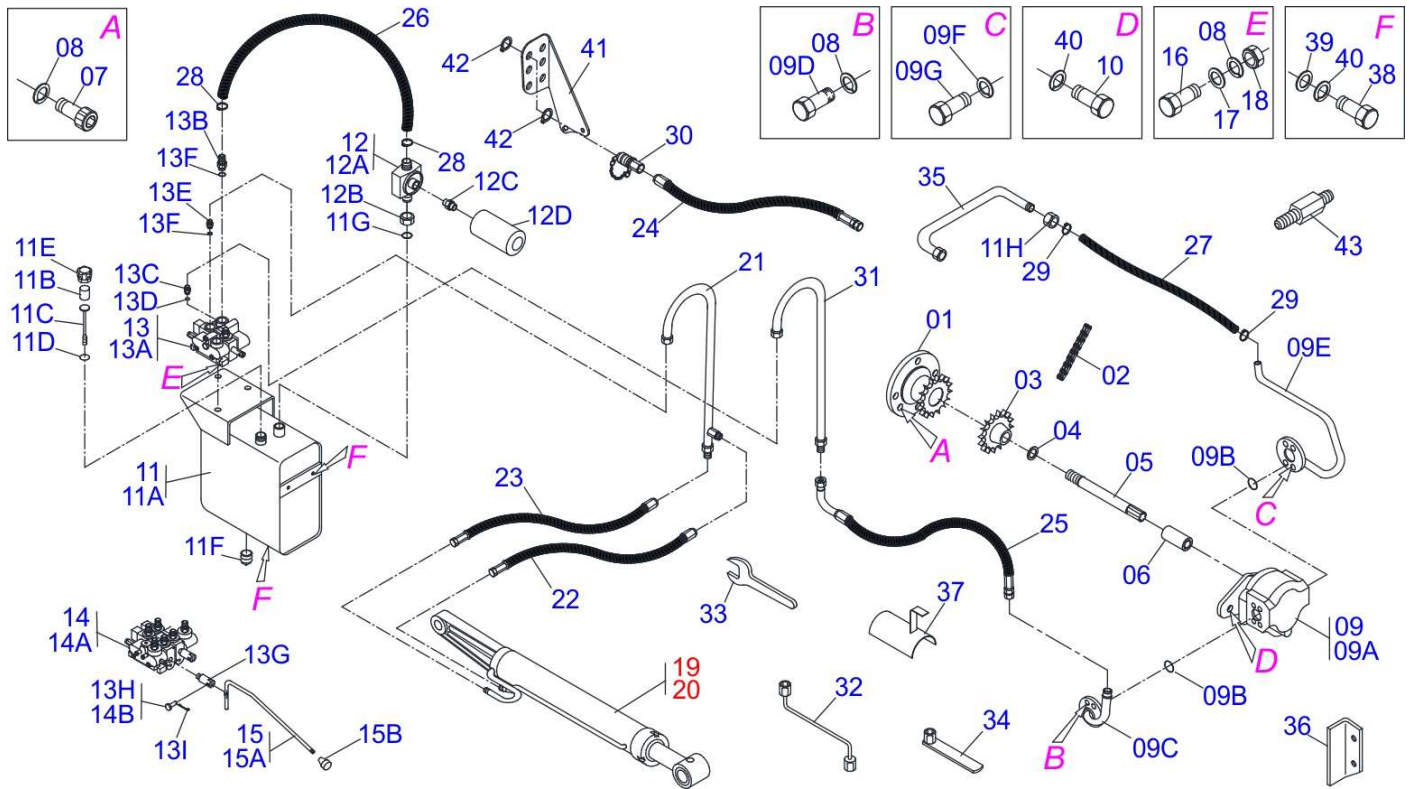

Artículo	Código	Descripción	CS	CD
01	0503050010		01	01
02	0503010455	CADENA 50-2 X 15 ESLABON + ENMIENDA	01	01
03	0503050075	ENGRANAJE 16Z	01	01
04	0501010890	ARANDELA APOYO	01	01
05	0501068964	EJE 348 X 7/8 UNC X 1.1/8-30G	01	01
06	0503030838	BUJE 1.1/8" X 61 ESTR	01	01
07	0503010175	TORNILLO 3/8" UNC X 1.1/4"	06	06
08	0503010025	ARANDELA PRESION 3/8	13	13
09	0501052129	BOMBA COMPLETA	01	01
09A	0503060045	BOMBA 40L 1/2"	01	01
09B	0503010173	ANILLO O'RING 2-220 N 3006-9B	02	02
09C	0501069661	DUCTO PRESION BOMBA	01	01
09D	0503010237	TORNILLO 3/8 UNC X 1	04	04
09E	0501069536	DUCTO SUCCION BOMBA	01	01
09F	0503010180	ARANDELA PRESION 7/16"	04	04
09G	0503010355	TORNILLO 7/16 UNC X 1	04	04
10	0503010920	TORNILLO 1/2 UNC X 1.1/2	02	02
11	0501047808	DEP+SITO ACEITE COMPL	01	01
11A	0501068882	DEP+SITO ACEITE	01	01
11B	0503030044	ELEM FILTRANTE AR	01	01
11C	0501060975	MEDIDOR ACEITE	01	01
11D	0503010185	ANILLO O'RING 2-221 N 3006-9B	01	01
11E	0502020472	CUERPO LA TAPA	01	01
11F	0503031604	TAPON 1/2 BSP	01	01
11G	0503010046	ANILLO O'RING 2-216 N 3006-9B	01	01
11H	0501016309	TUERCA 2" UNC 16FPP X 2.5/16"	01	01
12	0501041108	FILTRO RETORNO MAYOR COMPL	01	01
12A	0502050002	CABCT FILTRO RETORNO	01	01
12B	0501010594	TUERCA 1" BSP S 1.5/8"	01	01
12C	0501010595	NIPLE 1 NF SEXT.1.1/8 X 37	01	01
12D	0503010183	FILTRO RETORNO	01	01
13	0501040871	COMANDO 1/2" COMPLETO	01	
13A	0503060080	COMANDO 1/2"	01	



PD MF 265-4
CIRCUITO HIDRAULICO

2
0909092237

Artículo	Código	Descripción	CS	CD
13B	0501010591	BICO P/MANGUERA	01	01
13C	0501010590	NIPLE 7/8 NF	02	04
13D	0503010045	ANILLO O'RING 2-116 N 3006-9B	02	04
13E	0501010589	NIPLE R. 1.1/16UN SEXT 1.1/4 X 52	01	01
13F	0503010602	ANILLO O'RING 2-211 N 3006-9B	02	02
13G	0503030347	FIJADOR SUP PALANCA (SAUER DANFOSS)	01	02
13H	0501010593	PASADOR 7,93 X 25 X 1/2" X 28	01	
13I	0503010140	PASADOR ABIERTO 1/8" X 3/4"	01	02
14	0501040873	COMANDO DOBLE 1/2"	01	
14A	0503060081	COMANDO DOBLE 1/2"	01	
14B	0521010532	EJE UNION 7,93 X 23	02	
15	0501041196	PALANCA COMANDO COMPL.	01	02
15A	0501067556	ACCIONADOR MANDO (V-985-4)	01	01
15B	0503030878	MANOPLA PALANCA	01	01
16	0501010080	TORNILLO 3/8"	03	03
17	0501010984	ARANDELA PLANA	03	03
18	0503010026	TUERCA 3/8	03	03
19	0501044368	CILINDRO HIDRAULICO 44,45 X 85,7 X 920 X 483	01	01
20	0501044369	CILINDRO HIDRAULICO 44,45 X 85,7 X 920 X 483	01	01
21	0501068945	CONEXION CURVO	02	02
22	0501080103	MANGUERA 1/2 X 1200 TR-TR	02	02
23	0501080346	MANGUERA 1/2" X 2000 TR-TR	02	02
24	0501080308	MANGUERA 1/2 X 2750 TR-TM	02	
25	0501080708	MANGUERA 3/4 X 2450 TR-TC	01	01
26	0501013822	MANGUERA 1 X 650 AB-AB	01	01
27	0501010808	MANGUERA 1.1/4" X 1300 AB-AB	01	01
28	0503010184	ABRAZADERA	02	04
29	0503010243	ABRAZADERA	03	02
30	0501053835	HEMBRA ENGANCHE RAP 1/2 NPT	02	
31	0501064350	DUCTO PRESION COMANDO	01	01
32	0501068213	CLAVE DOBLE 5/8 X 3/4	01	01
33	0511010153	CLAVE FIXA 2.5/16	01	01
34	0501061617	LLAVE 1 CABO PLANO	01	01
35	0501063383	DUCTO SALIDA TANQUE	01	01
36	0501018735	APOYO FAROL	02	02
37	0511064563	PROTECTOR MANGUERA	01	01
38	0501010161	TORNILLO 1/2 UNC X 1.1/4	04	04
39	0511017302	ARANDELA PLANA 13.5 X 32.5 X 3.00	04	04
40	0503010019	ARANDELA PRESION 1/2"	06	06
41	0511019730	SOPORTE ENGANCHE RAPIDO	01	
42	0503010217	ANILLO TENSOR 501040 (PARA EJE)	04	
43	0521014428	EXTENSION HEX	02	02

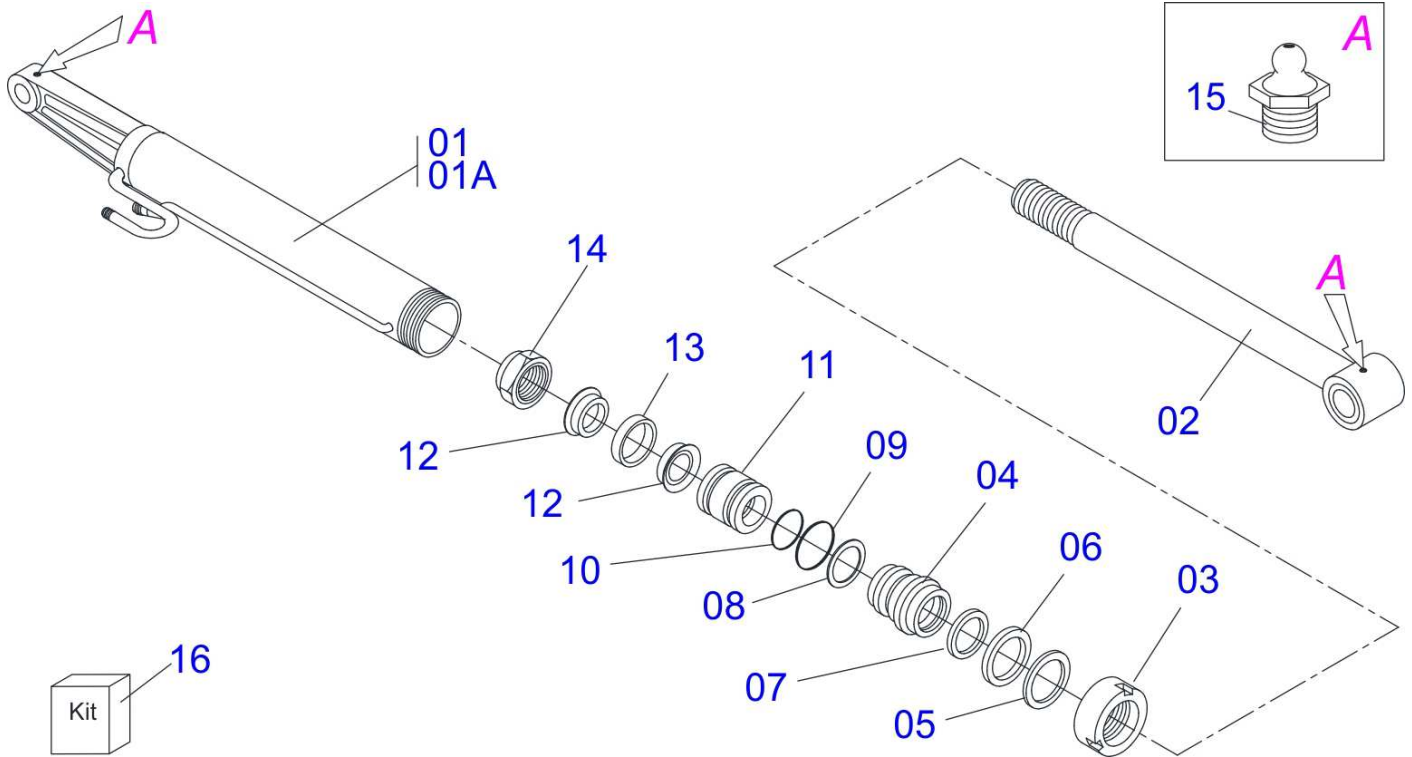

Artículo	Código	Descripción	QT
01	0501063606	CAMISA 85,7 X 483 DER	01
01A	0501063607	CAMISA 85,7 X 483 IZQ	01
02	0501069048	EXTENSOR 44,45 X 648	01
03	0502010993	TAPA MOVIL 85,72	01
04	0502010781	SOPORTE ANILLOS 44,45 X 85,72	01
05	0503010761	ANILLO RASCADOR D-1750	01
06	0503010990	ANILLO 1870-1750-375-B	01
07	0503010949	ANILLO GUIA INTERNO W2-2000-500	01
08	0503011060	ANILLO BACK-UP 8-336	01
09	0503010976	ANILLO O'RING 2-336 N 3006-9B	01
10	0503010042	ANILLO O'RING 2-214 N 3006-9B	01
11	0502010843	EMBOLO 44,45 X 85,7	01
12	0503010170	ANILLO 3120 2750	02
13	0503010948	ANILLO GUIA EXTERNO W4-3346-590	01
14	0503010063	TUERCA 1" UNF	01
15	0503010002	GRASERA 1800	02
16	0501031796	JUEGO REPARO COMPLETO CILINDRO	01

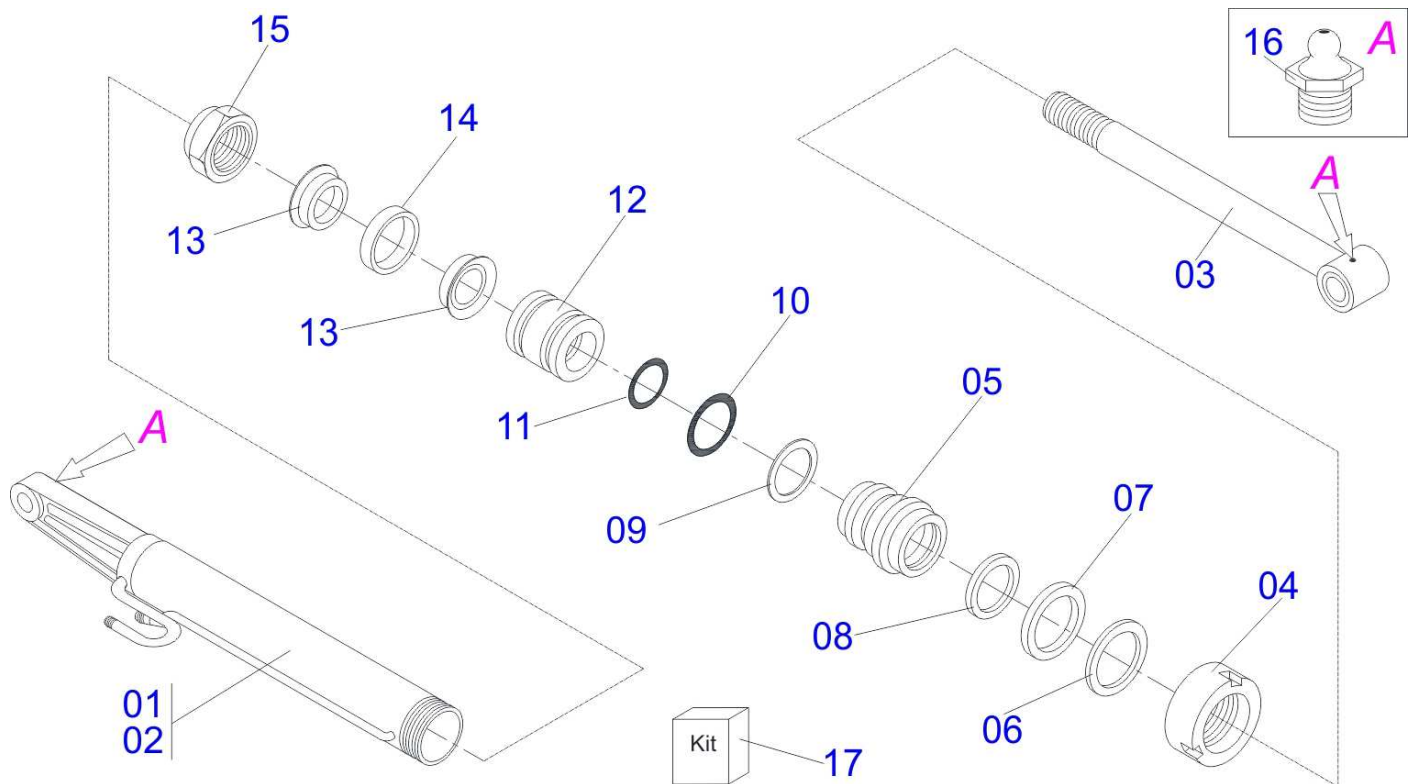

Artículo	Código	Descripción	QT
00	0501046992	CILINDRO HIDRAULICO 44,45 X 85,7 X1010 X 400	01
00A	0501046993	CILINDRO HIDRAULICO 44,45 X 85,7 X1010 X 400	01
01	0501068206	CAMISA 85,72 X 855 DIR PD MF 292-4	01
02	0501068207	CAMISA 85,72 X 855 ESQ PD MF 292-4	01
03	0501068208	EXTENSOR 44,45 X 670	01
04	0502010993	TAPA MOVIL 85,72	01
05	0502010781	SOPORTE ANILLOS 44,45 X 85,72	01
06	0503010761	ANILLO RASCADOR D-1750	01
07	0503010990	ANILLO 1870-1750-375-B	01
08	0503010949	ANILLO GUIA INTERNO W2-2000-500	01
09	0503011060	ANILLO BACK-UP 8-336	01
10	0503010976	ANILLO O'RING 2-336 N 3006-9B	01
11	0503010042	ANILLO O'RING 2-214 N 3006-9B	01
12	0502010843	EMBOLO 44,45 X 85,7	01
13	0503010170	ANILLO 3120 2750	02
14	0503010948	ANILLO GUIA EXTERNO W4-3346-590	01
15	0503010063	TUERCA 1" UNF	01
16	0503010002	GRASERA 1800	02
17	0501031796	JUEGO REPARO COMPLETO CILINDRO	01



MARCHESAN IMPLEMENTOS E MÁQUINAS AGRÍCOLAS TATU S.A.
AV. Marchesan, 1979 - Casilla de Correos, 131 - CEP 15994-900 - Matão - SP - Brazil
Fono +55 16.3382-8282
(FAX Parts) + 55 16.3382. 8297 - (Export) + 55 16.3382.1003
e.mail: tatu@marchesan.com.br www.marchesan.com.br

Publicaciones Técnicas: Desarrollo
LUIZ CANDIDO

Publicaciones Técnicas: Revisión
JOSÉ DOMINGOS GASPARI

Contactos Catálogo:
E-mail = jgaspari@marchesan.com.br

**ORIGINAL PARTS
TATU**

