

# **PARTS CATALOG**

## **IMPLEMENTS FOR SUGAR CANE**

### **SACM-T**

**Code: 0501091303**



**Series: S-0507**

**Rev.: 00**

**Date Rev.: MAIO/2007**

**ORIGINAL PARTS  
TATU**



# INDEX

0909092783	SACM-T MECANICO	.....	1
0909092785	GEAR BOX	.....	2
0909092779	1300/1400/1500 CTP 2L SACM-T	.....	3
0909092786	FERTILIZER BEAM ASSY	.....	4
0511044355	24" BLADE DISC ASSY	.....	5
0501054884	SHANKS SYSTEM ASSY SACM3	.....	6
0909090433	OIL BATH BEARING	.....	7
0501054945	REAR LEVELING	.....	8

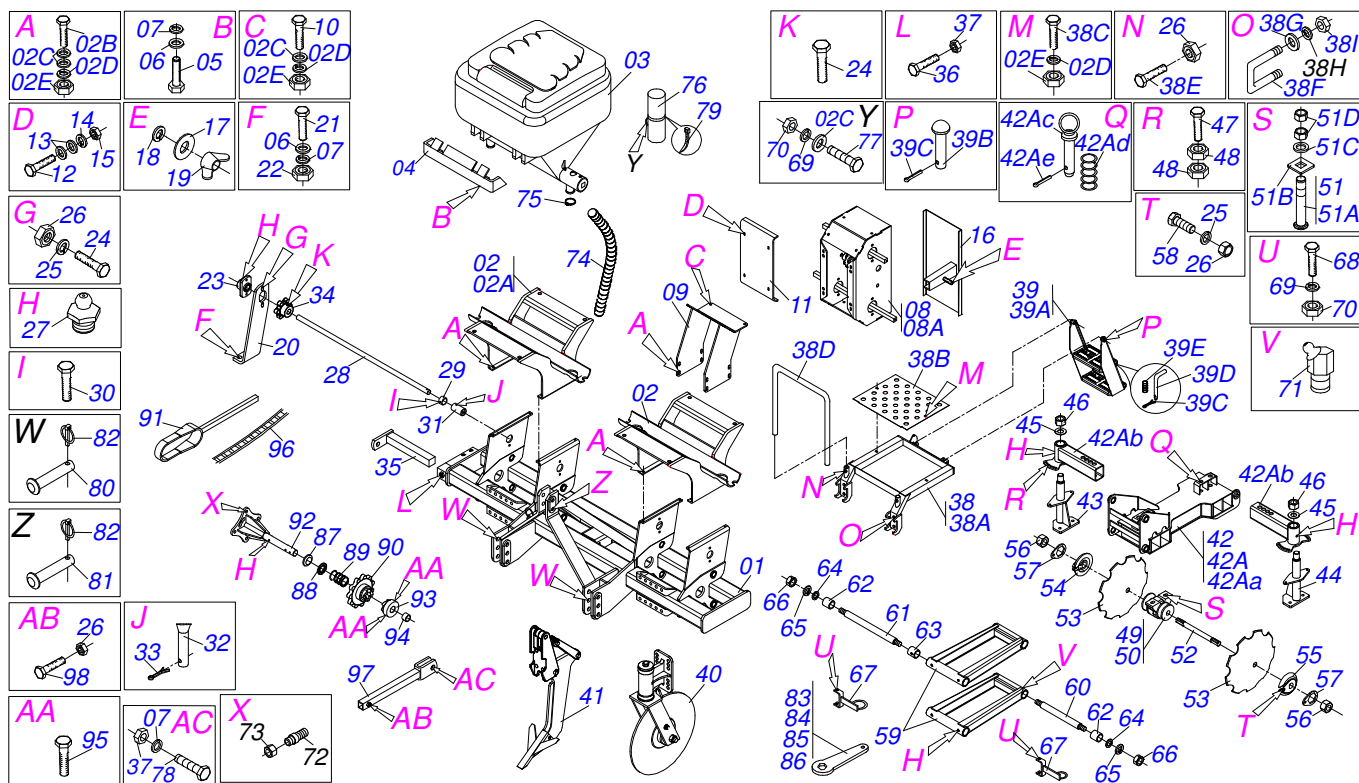

Item	Code	Description	QT
01	0511067104	FRAME	01
02	0511045926	SILO SUPPORT ASSY	02
02A	0511068657	SILO SUPPORT	01
02B	0503010849	3/8" X 1-1/2" BOLT	08
02C	0501010984	FLAT WASHER	21
02D	0503010025	3/8 SPRING WASHER	14
02E	0503010026	3/8" NUT	14
03	0501057624	FERTILIZER BEAM ASSY	01
04	0511068656	FERTILIZER BEAM LOCK	02
05	0503010233	5/8" X 2-1/2" BOLT	04
06	0501012140	FLAT WASHER	08
07	0503010027	SPRING WASHER	07
08	0511045952	GEAR BOX	01
08A	0501055624	GEAR BOX	01
09	0511067107	SPEED SUPPORT VARIADOR	01
10	0503010237	3/8" X 1" BOLT	04
11	0541019052	SPEED COVER VARIADOR	01
12	0503010282	1/4" X 3/4" BOLT	04
13	0511017303	FLAT WASHER	08
14	0503010143	SPRING WASHER	04
15	0503010144	1/4" NUT	04
16	0511066626	SPEED COVER BOX	01
17	0521013303	WASHER	01
18	0503010179	SPRING WASHER	01
19	0503010499	5/16" UNC BUTTERFLY NUT	01
20	0511068170	SUPPORT BEARING	01
21	0501010100	5/8 UNC X 2 C S G.5 BOLT	02
22	0503010013	5/8" NUT	02
23	0501110014	AGRICULTURAL BEARING	01
24	0501010077	1/2" X 2" BOLT	04
25	0503010019	1/2" SPRING WASHER	10
26	0503010060	1/2" NUT	13
27	0503010002	1800 GREASE FITTING	09



SACM-T  
SACM-T MECANICO

Item	Code	Description	QT
28	0541018896	DRIVER AXLE	01
29	0501010783	DRIVING AXLE LUCK	01
30	0503013662	1/2" X 1" BOLT	01
31	0511067108	SLEEVE AXLE DRIVING	01
32	0521010530	COUPLING SHAFT	01
33	0503010140	1/8" X 3/4" COTTERPIN	01
34	0502011311	6Z GEAR	01
35	0511068171	EAR DRIVING	01
36	0503010232	5/8" X 1.3/4" BOLT	01
37	0503010013	5/8" NUT	02
38	0501057649	PLATFORM ASSY	01
38A	0511068710	PLATFORM SACM/SA-T S-0207	01
38B	0541018908	PLATFORM BODY	01
38C	0503011268	3/8" X 2-1/2" BOLT	02
38D	0551015666	HANDRAIL BODY	01
38E	0503014007	1/2" X 1-1/4" BOLT	02
38F	0521010660	3/4" X 5.9" X 5.1" FASTENER	02
38G	0501010322	FLAT WASHER	04
38H	0503010023	SPRING WASHER	04
38I	0503010014	3/4" NUT	04
39	0501057647	LADDER	01
39A	0501069281	RIGHT LADDER	01
39B	0521010542	COUPLING SHAFT	02
39C	0503010257	1/8" X 1" COTTERPIN	03
39D	0521011249	LADDER LOCK PIN	01
39E	0503030190	0.5" X 1.6" X 0.05" SPRING	01
40	0511044355	24" BLADE DISC ASSY	02
41	0501054884	SHANKS SYSTEM ASSY SACM3	02
42	0511045874	GRID ASSY	02
42A	0501055628	FRAME HORROW TANDEM	01
43	0511063098	DISC SUPPORT UPPER	02
44	0511063099	DISC REG SUPPORT LOWER	02
45	0521012120	WASHER	04
46	0501010110	1.1/2" NUT	04
47	0503011195	7/16" X 1.3/4" BOLT	08
48	0503010244	7/16" NUT	16
49	0501049008	7.2" X 1-1/4" OIL BATH BEARING	02
50	0501049009	7.2" X 1-1/4" OIL BATH BEARING	02
51	0501048963	5/8" X 2-1/2" BOLT ASSY	08
52	0521012160	1.1/4" X 290 AXLE	04
53	0602025011	0.7" X 0.2" NOTCHED DISC BLADE	08
54	0502010834	1-1/4" INNER AXLE WASHER	04
55	0502010835	1-1/4" EXTERNAL AXLE WASHER	04
56	0501010087	1.1/4" NUT	08
57	0501010455	1.1/4" NUT LOCK	08
58	0501010161	1/2" X 1.1/4" BOLT	08
59	0511064991	ROCKING DRIVER	02
60	0521012121	AXLE SMALEER PIVOT	02
61	0541010320	DRIVER ROCKING AXLE LARGER PIVOT	02
62	0521012122	DRIVER ROCKING SLEEVE SUPPORT	08
63	0541010319	SLEEVE	04
64	0521012087	FLAT WASHER	08
65	0503010012	1" SPRING WASHER	08
66	0503010340	1" NUT	08
67	0511067339	HOSE SUPPORT	02
68	0503013096	5/16" X 4" BOLT	02
69	0503010179	SPRING WASHER	03
70	0503010337	5/16" NUT	03
71	0503010003	1845 GREASE FITTING	04
72	0501010762	STUD	04
73	0501016992	3/4" CONIC NUT	04
74	0551013640	2.1/2" X 1100 HOSE ASSY	04



SACM-T  
SACM-T MECANICO

Item	Code	Description	QT
75	0503011266	CLAMP 2.1/4" A 3" 57-76	04
76	0503060100	HAND BOOK COMPARTMENT	01
77	0503010371	5/16" X 1" BOLT	01
78	0503010899	5/8" X 2-1/4" BOLT	01
79	0503010267	NYLON CLAMP	01
80	0521012124	COUPLING SHAFT	02
81	0521012533	COUPLING SHAFT	01
82	0503030085	LOCK PIN	03
83	0521012126	1.3" CABLE FLAT WRENCH HEX	01
84	0531014773	2.3 CABLE FLAT WRENCH HEX	01
85	0521012199	1.6" GANG BOLT WRENCH	01
86	0521012200	2" CABLE FLAT WRENCH	01
87	0511016819	CONICAL SPRING WASHER	04
88	0501010765	SPINDLE GUIDE	01
89	0503030086	COMPRESSION SPRING	01
90	0502011321	11Z GEAR WITH RIGHT DRAGGER	01
91	0511068861	COUPLING/UNCOUPLING ARM	01
92	0501061186	MOTOR SUPPORT	01
93	0502011379	RH FOLLOWER	01
94	0501014453	LOCK BUSHING	01
95	0503010734	1/2" X 2-1/2" BOLT	03
96	0503010253	57 CHAIN X 73 LINK	1
97	0511068860	ROD DRIVING	01
98	0501010161	1/2" X 1.1/4" BOLT	01

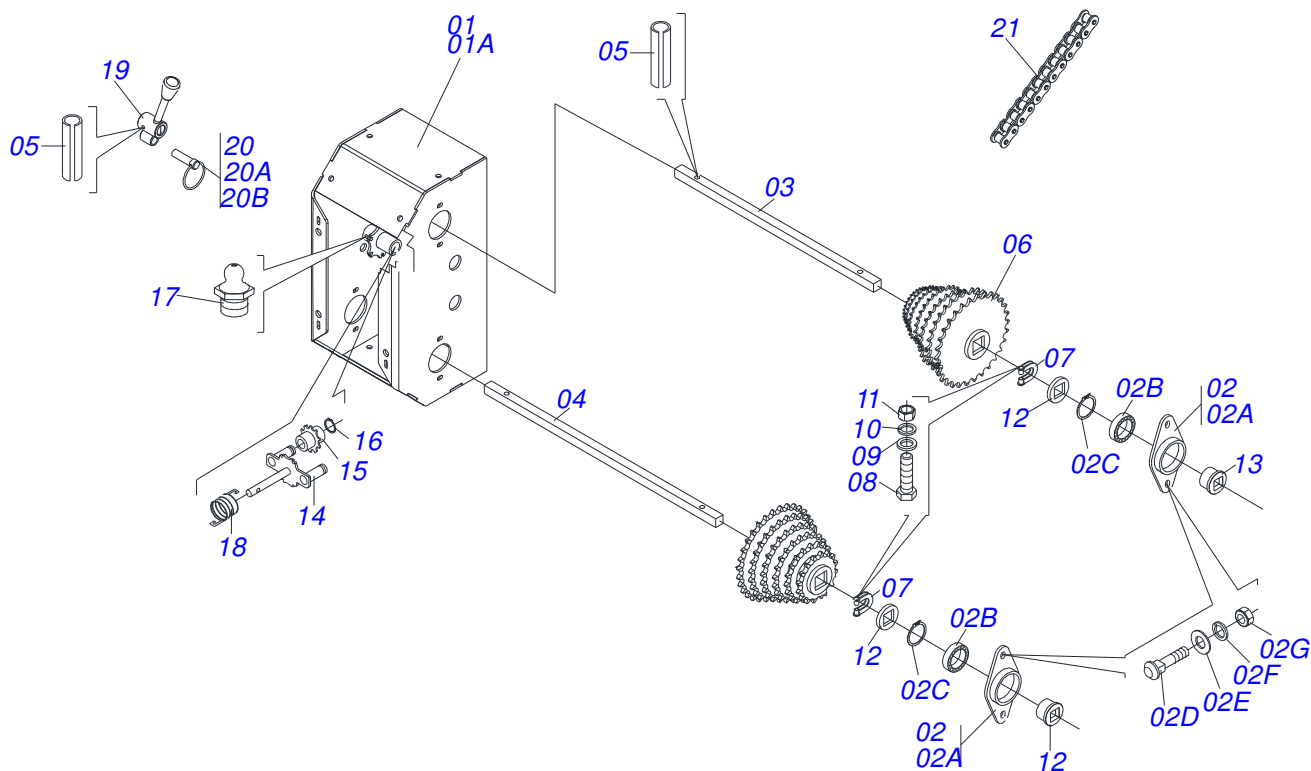

Item	Code	Description	
01	0501055624	GEAR BOX	01
01A	0511066625	SPEED BOX VARIADOR	01
02	0501053361	SPEED DOUB BEARING VARIADOR	04
02A	0502011987	DOUBLE HOUSING BEARING	01
02B	0503011410	ROLLER BEARING	02
02C	0503011105	SEAL RING	01
02D	0503011953	5/16" X 1" BOLT	02
02E	0501010694	FLAT WASHER	02
02F	0503010179	SPRING WASHER	02
02G	0503010337	5/16" NUT	02
03	0521013283	SPEED AXLE TRANSMISSION	01
04	0551015668	SQUARE SHAFT	01
05	0503010292	0.2" X 1.6" SPRING PIN	05
06	0501069700	FERTILIZER GEAR ASSY	02
07	0521010691	AXLE FASTENER	04
08	0503010373	1/4" X 2" BOLT	04
09	0511017303	FLAT WASHER	04
10	0503010143	SPRING WASHER	04
11	0503010144	1/4" NUT	04
12	0521018630	1.4" X SQUARE 0.8" WASHER	04
13	0503031527	AGRICULTURAL BEARING	04
14	0511060393	CHAIN TENSIONER ASSY	01
15	0503031805	11Z 1/2" GEAR	02
16	0503010302	501019 SEAL RING	02
17	0503010002	1800 GREASE FITTING	01
18	0503031367	SPRING	01
19	0502011758	REAR TENSIONER LEVER	01
20	0501048790	AXLE WITH LINK ASSY	01
20A	0521012476	GEAR BOX LEVER AXLE	01
20B	0503031369	LINK	01
21	0503012143	78 CHAIN X 40-1 LINK + REDUCTION	01

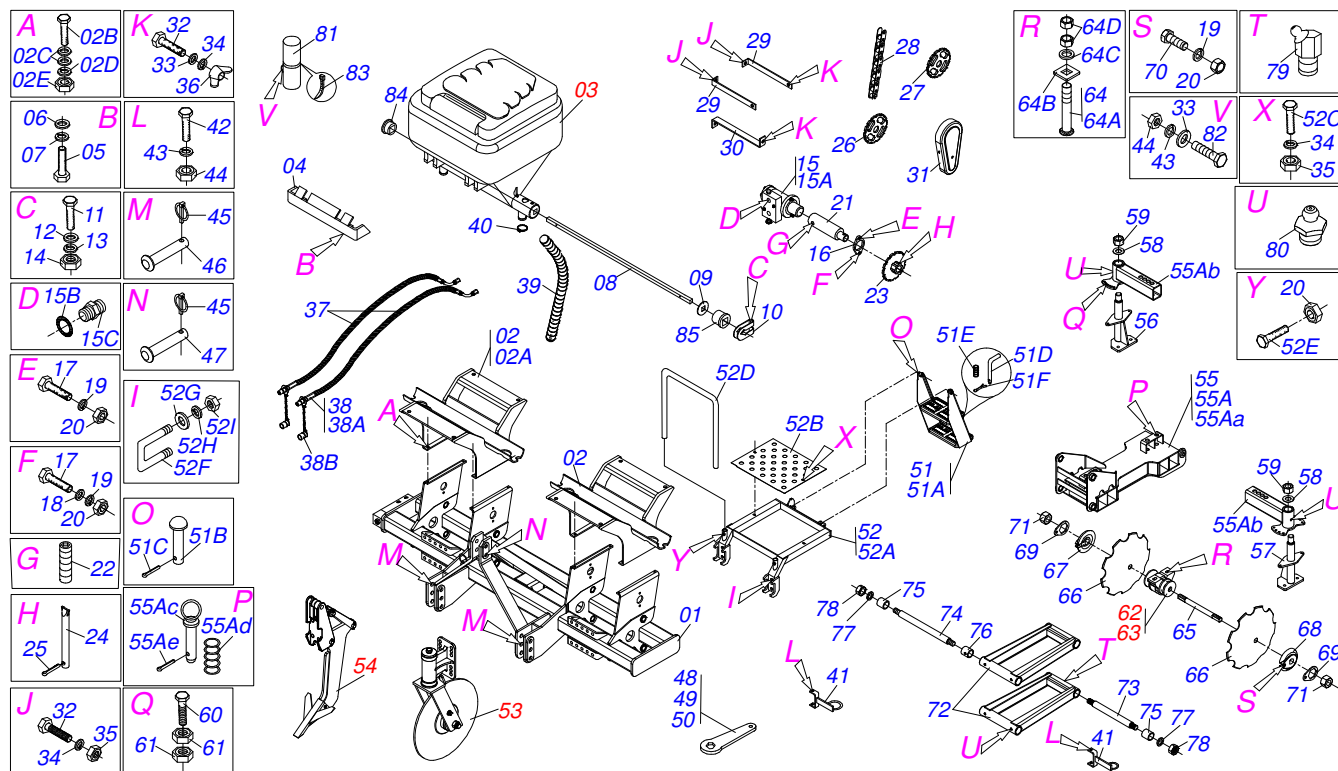

Item	Code	Description	QT
01	0511067104	FRAME	01
02	0511045926	SILO SUPPORT ASSY	02
02A	0511068657	SILO SUPPORT	01
02B	0503010849	3/8" X 1-1/2" BOLT	04
02C	0501010984	FLAT WASHER	08
02D	0503010025	3/8 SPRING WASHER	04
02E	0503010026	3/8" NUT	04
03	0501057624	FERTILIZER BEAM ASSY	01
04	0511068656	FERTILIZER BEAM LOCK	02
05	0503010233	5/8" X 2-1/2" BOLT	04
06	0501012140	FLAT WASHER	04
07	0503010027	SPRING WASHER	04
08	0521013959	3/4" X 30.2" SQUARE SHAFT	01
09	0521018630	1.4" X SQUARE 0.8" WASHER	02
10	0521010691	AXLE FASTENER	02
11	0503010373	1/4" X 2" BOLT	02
12	0511017303	FLAT WASHER	02
13	0503010143	SPRING WASHER	02
14	0503010144	1/4" NUT	02
15	0501053421	VALVE MOTOR HYDRAULIC ASSY	01
15A	0503012829	VALVE HYDRAULIC MOTOR ASSY	01
15B	0503010045	2-116 N 3006-9B O'RING	02
15C	0501010590	7/8" REDUCTION NIPPLE	02
16	0541019115	HYDRAULIC MOTOR FLANGE	01
17	0503011172	1/2" X 2-1/2" BOLT	02
18	0511017302	FLAT WASHER	01
19	0503010019	1/2" SPRING WASHER	10
20	0503010060	1/2" NUT	12
21	0511067266	HIDRAULIC MOTOR AXLE	01
22	0503011136	1/2" X 1/2" CSI BOLT	01
23	0502010411	10Z GEAR	01
24	0521010530	COUPLING SHAFT	01
25	0503010140	1/8" X 3/4" COTTERPIN	01



## 1300/1400/1500 CTP 2L SACM-T

0909092779

Item	Code	Description	QT
26	0502011318	10Z GEAR	01
27	0502011349	18Z P 1.2" SH 3/4" GEAR	01
28	0503014266	2050 CHAIN X 31 LINK + MENDING+REDUCTION	01
29	0551015602	CHAIN CAP UPPER SUPPORT	02
30	0551015603	CHAIN CAP LOWER SUPPORT	01
31	0503032920	CHAIN CAP	01
32	0503011087	3/8" X 1" BOLT	05
33	0501010984	FLAT WASHER	04
34	0503010025	3/8 SPRING WASHER	07
35	0503010026	3/8" NUT	04
36	0503010209	3/8" UNC BUTTERFLY NUT	03
37	0501080097	1/2" X 98" TC-TM HOSE ASSY	02
38	0501053834	MALE QUICK COUPLING AGRICULTURAL WITH	02
38A	0503011627	QUICK CONNECTION (MALE) AGR 1/2 NPT	01
38B	0503011882	QUICK CONNECTION COVER	01
39	0551013640	2.1/2" X 1100 HOSE ASSY	04
40	0503011266	CLAMP 2.1/4" A 3" 57-76	04
41	0511067339	HOSE SUPPORT	04
42	0503013096	5/16" X 4" BOLT	04
43	0503010179	SPRING WASHER	05
44	0503010337	5/16" NUT	05
45	0503030085	LOCK PIN	03
46	0521012124	COUPLING SHAFT	02
47	0521012533	COUPLING SHAFT	01
48	0531014773	2.3 CABLE FLAT WRENCH HEX	01
49	0521012199	1.6" GANG BOLT WRENCH	01
50	0521012200	2" CABLE FLAT WRENCH	01
51	0501057647	LADDER	01
51A	0501069281	RIGHT LADDER	01
51B	0521010542	COUPLING SHAFT	02
51C	0503010257	1/8" X 1" COTTERPIN	02
51D	0521011249	LADDER LOCK PIN	01
51E	0503030190	0.5" X 1.6" X 0.05" SPRING	01
51F	0503030190	0.5" X 1.6" X 0.05" SPRING	01
52	0501057649	PLATFORM ASSY	01
52A	0511068710	PLATFORM SACM/SA-T S-0207	01
52B	0541018908	PLATFORM BODY	01
52C	0503011268	3/8" X 2-1/2" BOLT	02
52D	0551015666	HANDRAIL BODY	01
52E	0503014007	1/2" X 1-1/4" BOLT	02
52F	0521010660	3/4" X 5.9" X 5.1" FASTENER	02
52G	0501010322	FLAT WASHER	04
52H	0503010023	SPRING WASHER	04
52I	0503010014	3/4" NUT	04
53	0511044355	24" BLADE DISC ASSY	02
54	0501054884	SHANKS SYSTEM ASSY SACM3	02
55	0511045874	GRID ASSY	02
55A	0501055628	FRAME HORROW TANDEM	01
55Aa	0511067115	ROCKING HORROW	01
55Ab	0501069469	DISC REG DRIVER REG	04
55Ac	0501069472	DRIVER REG LOCK PIN	04
55Ad	0503030978	COMPRES SPRING	04
55Ae	0503010038	3/16 X 2 COTTERPIN	04
56	0511063098	DISC SUPPORT UPPER	02
57	0511063099	DISC REG SUPPORT LOWER	02
58	0521012120	WASHER	04
59	0501010110	1.1/2" NUT	04
60	0503011195	7/16" X 1.3/4" BOLT	08
61	0503010244	7/16" NUT	16
62	0501049008	7.2" X 1-1/4" OIL BATH BEARING	02
63	0501049009	7.2" X 1-1/4" OIL BATH BEARING	02
64	0501048963	5/8" X 2-1/2" BOLT ASSY	08





Item	Code	Description	QT
64A	0501014177	5/8" X 2-1/2" BOLT	08
64B	0501010947	5/8 NUT LOCK	08
64C	0501012140	FLAT WASHER	08
64D	0503010013	5/8" NUT	16
65	0521012160	1.1/4" X 290 AXLE	04
66	0602025011	0.7" X 0.2" NOTCHED DISC BLADE	08
67	0502010834	1-1/4" INNER AXLE WASHER	04
68	0502010835	1-1/4" EXTERNAL AXLE WASHER	04
69	0501010455	1.1/4" NUT LOCK	08
70	0501010161	1/2" X 1.1/4" BOLT	08
71	0501010087	1.1/4" NUT	16
72	0511064991	ROCKING DRIVER	02
73	0521012121	AXLE SMALEER PIVOT	02
74	0541010320	DRIVER ROCKING AXLE LARGER PIVOT	02
75	0521012122	DRIVER ROCKING SLEEVE SUPPORT	08
76	0541010319	SLEEVE	04
77	0521012087	FLAT WASHER	08
78	0503010063	1" SELF-ALIGNING NUT	08
79	0503010003	1845 GREASE FITTING	04
80	0503010002	1800 GREASE FITTING	08
81	0503060100	HAND BOOK COMPARTMENT	01
82	0503010371	5/16" X 1" BOLT	01
83	0503010267	NYLON CLAMP	01
84	0503031527	AGRICULTURAL BEARING	02
85	0503030275	AGRICULTURAL BEARING	01

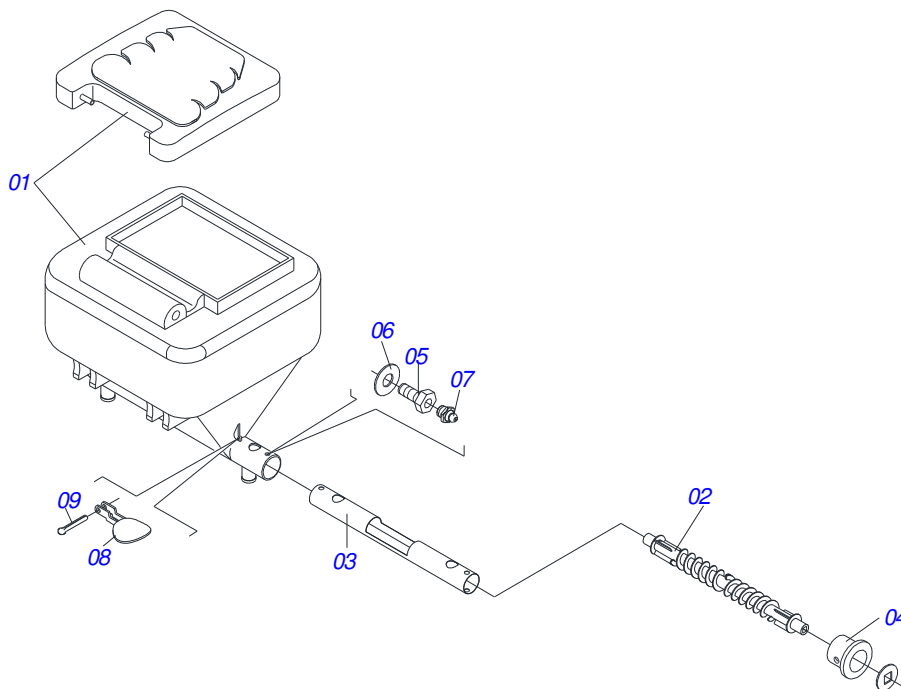

Item	Code	Description	
00	0501057624	FERTILIZER BEAM ASSY	01
01	0503061670	COVER ORANGE BOX FERTIL YELLOW	01
02	0511068620	FERTILIZER CONDUCTOR	01
03	0551015492	TUBE COATED	01
04	0551015225	FERTILIZER CONDUCTOR BEARING	02
05	0541014215	BEARING BOLT	04
06	0511017302	FLAT WASHER	04
07	0503010691	1/4" GREASE FITTING	04
08	0551013391	COVER SOCKET	02
09	0503010362	1/8" X 1.1/4" COTTERPIN	02

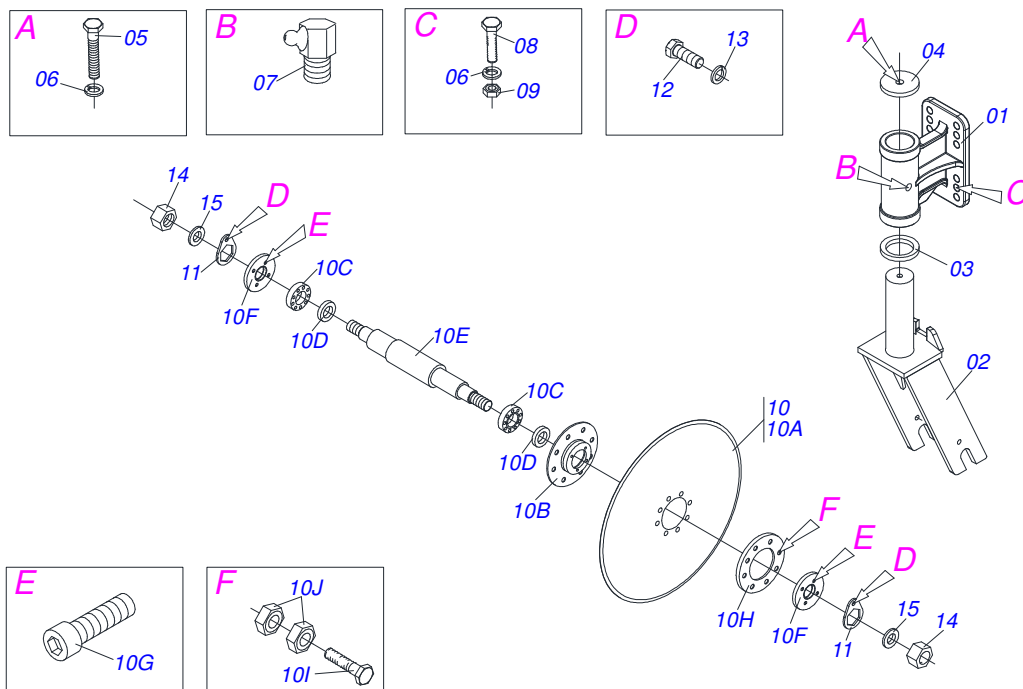

Item	Code	Description	
01	0502012370	WITH BLADE DISC SUPPORT	01
02	0511067105	BLADE DISC FORK	01
03	0541018869	FLAT WASHER	01
04	0541018868	FLAT WASHER	01
05	0501010098	HEX BOLT 3/4 UNC X 2 C S G.5 ZN	01
06	0503010023	SPRING WASHER	05
07	0503010004	1890 GREASE FITTING	01
08	0501010500	3/4"X3"BOLT	04
09	0503010014	3/4" NUT	04
10	0501056943	24" BLADE DISC	01
10A	0603030044	24" X 0.2" FLAT PLAIN DISC	01
10B	0502011478	DISC HUB	01
10C	0503011291	6209 BALL BEARING	02
10D	0503012106	00521-BR SEAL	02
10E	0521012661	BLADE DISC AXLE HUB	01
10F	0502011477	BLADE DISC HOUSIG CP	02
10G	0521011824	BLADE DISC FLANGE OUTER	01
10H	0503010134	3/8" X 1" BOLT	08
10I	0503011172	1/2" X 2-1/2" BOLT	08
10J	0503010060	1/2" NUT	16
11	0501069637	AXLE NUT LOCK	02
12	0503010962	5/8" X 1-1/4" BOLT	02
13	0503010027	SPRING WASHER	02
14	0521012664	FLAT WASHER	02
15	0501010087	1.1/4" NUT	02

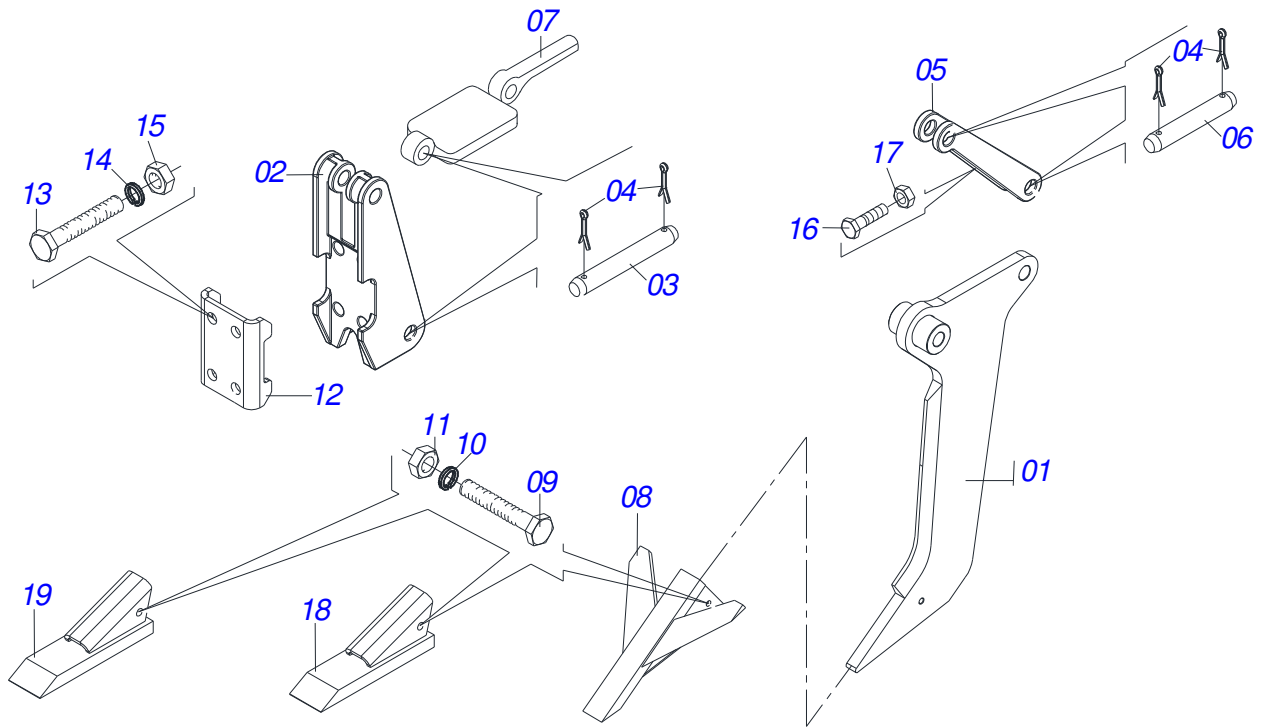

Item	Code	Description	QT
01	0511064994	FURROWER ARM	01
02	0502011165	REAR FIXER	01
03	0511015688	1.1" X 7.1" COUPLING SHAFT	02
04	0503010571	1/4" X 1.1/2" COTTERPIN	08
05	0502011164	SUPPORT SPRING	01
06	0511015689	1.1" X 3.5" COUPLING SHAFT	02
07	0521011631	AUTOMATIC RESET	01
08	0511067838	POINT SUBSOILER	01
09	0503011236	3/8" X 2" BOLT	01
10	0503011443	SPRING WASHER	01
11	0503010026	3/8" NUT	01
12	0502011166	FRONT FIXER	01
13	0511019527	1" X 8" BOLT	04
14	0503011438	SPRING WASHER	04
15	0503010340	1" NUT	04
16	0503011195	7/16" X 1.3/4" BOLT	01
17	0503010244	7/16" NUT	01
18	0511067842	SUBSOILER TIP	02
19	0511067841	POINT SUBSOILER	02

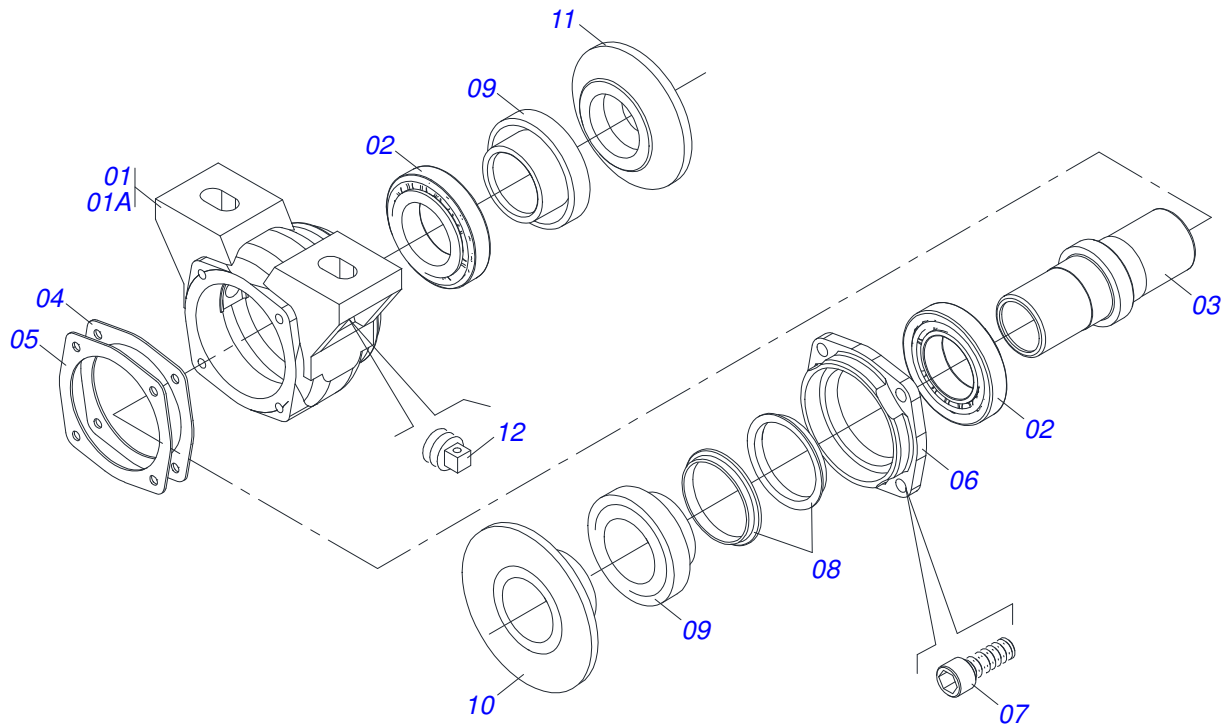

Item	Code	Description	
00	0501049008	7.2" X 1-1/4" OIL BATH BEARING	01
00A	0501049009	7.2" X 1-1/4" OIL BATH BEARING	01
01	0502011765	HOUSING DM	01
01A	0502011766	HOUSING DM	01
02	0503010111	30210 ROLLER BEARING	02
03	0502040218	AXLE	01
04	0503030013	4.4" X 3.5" X 0.004" JOINT	02
05	0503030684	4.4" X 3.5" X 0.004" JOINT	01
06	0502020424	HOUSING CAP DM	01
07	0503010134	3/8" X 1" BOLT	04
08	0503030026	SEAL LP JB-253	02
09	0502010541	SEAL RETAINER	02
10	0502010073	OUTER FLANGE	01
11	0502010074	INNER FLANGE	01
12	0503010856	OIL PLUG	01

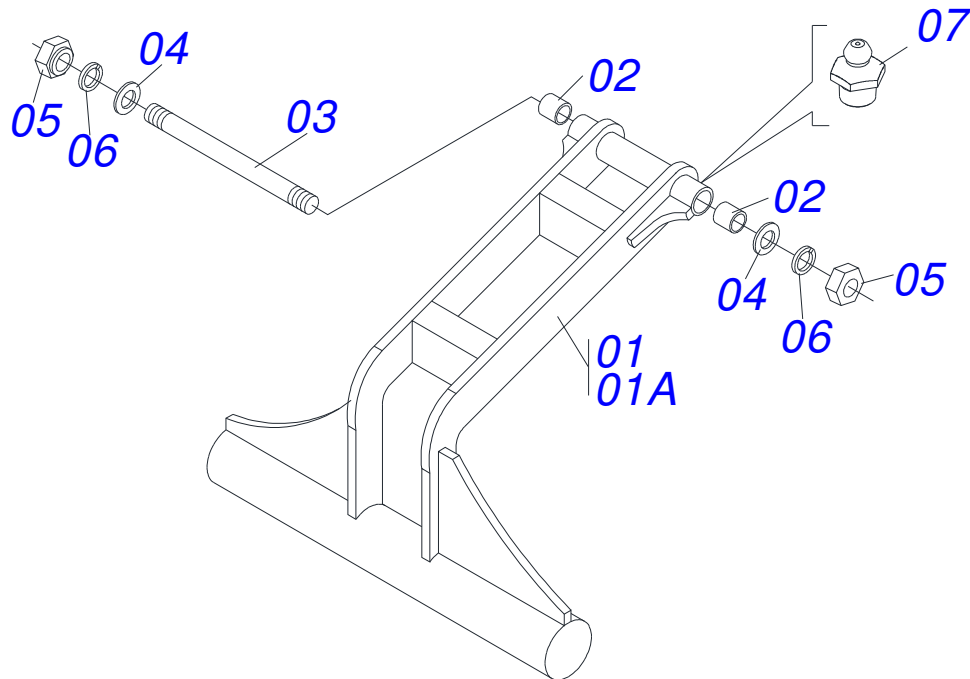

Item	Code	Description	
01	0501054945	REAR LEVELING	01
01A	0511064998	REAR LEVELING	01
02	0531010280	SLEEVE ARM REAR LEVELING	02
03	0531010281	REAR LEVELING AXLE ARM	01
04	0521012087	FLAT WASHER	02
05	0503010063	1" SELF-ALIGNING NUT	02
06	0503010012	1" SPRING WASHER	02
07	0503010002	1800 GREASE FITTING	02





**MARCHESAN IMPLEMENTOS E MÁQUINAS AGRÍCOLAS TATU S.A.**

AV. Marchesan, 1979 - Post office box, 131 - CEP 15994-900 - Matão - SP - Brazil

Phone +55 16.3382-8282

(FAX Parts) + 55 16.3382. 8297 - (Export) + 55 16.3382.1003

e.mail: [tatu@marchesan.com.br](mailto:tatu@marchesan.com.br) [www.marchesan.com.br](http://www.marchesan.com.br)

**Technical Publications: Elaboration**

ALESSANDRA PATRICIA KAWAHARA CARRILI

*Contact Catálogo:*

*E-mail = [jgaspari@marchesan.com.br](mailto:jgaspari@marchesan.com.br)*

**ORIGINAL PARTS  
TATU**

