

AUXILIARY PRODUCTS

STA1

Code: 0501091084
Series: S-0888
Revision: 00
Date Revision: JUNHO/2023

PARTS CATALOGUE



MARCHESAN



PRODUCTS

Code	Description
0113010026	STA-1 RASPADEIRA AGR PN S-888
0113010015	STA-1 RASPADEIRA AGR S/PNEUS S-0888

ATTENTION: IMPORTANT

Marchesan S.A. reserves the right to improve and/or modify the technical features of its products, without obligation to do the same with those products already sold and without prior knowledge of the dealer or the customer. The photos are only illustrative.



INDEX

0909092708	FRAME ASSY	1
0501056361	SEMI MOUNTED FRAME	2
0501051609	ASSY WHEELED BOX	3
0501050226	FLIP ASSY	4
0511050685	ASSY HITCH	5
0511058433	HYDRAULIC CYLINDER 38.10 X 63.50 X 970.50 X 708	6
0501053834	MALE QUICK COUPLER	7
0503060046	WHEEL WITH TIRE 900 X 20-14L ASSY	8

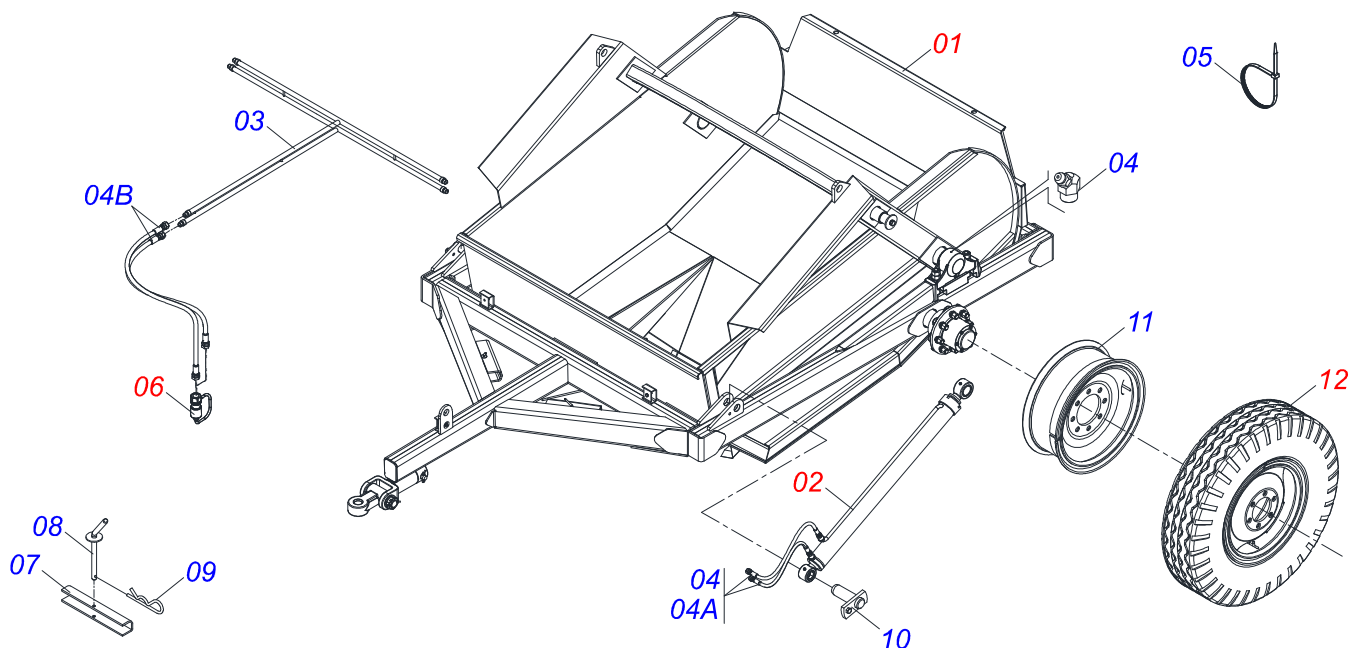

Item	Code	Description	See page	QT
01	0501056361	SEMI MOUNTED FRAME	2	01
02	0511058433	HYDRAULIC CYLINDER 38.10 X 63.50 X 970.50 X 6708		02
03	0501063308	OIL DISTRIBUTOR		01
04	0501051066	HOSE KIT		01
04A	0501080189	1/2" X 28" TR-TR HOSE ASSY		04
04B	0501080072	1/2" X 63" TR-TM HOSE ASSY		02
05	0503013527	CLAMP ZIPER		04
06	0501053834	MALE QUICK COUPLER	7	02
07	0511017592	11.8" X 1.6" TRANSPORT LOCK		02
08	0501068994	8,30 X 78 LOCK PIN		02
09	0503030168	HITCH PIN CLIP		02
10	0511062927	1.5" X 4.9" PIVOT SHAFT		02
11	0501063939	2.6"X0.8"X5.1"X 6F0.75"X6.8" WHEEL		02
12	0503060046	WHEEL WITH TIRE 900 X 20-14L ASSY	8	02

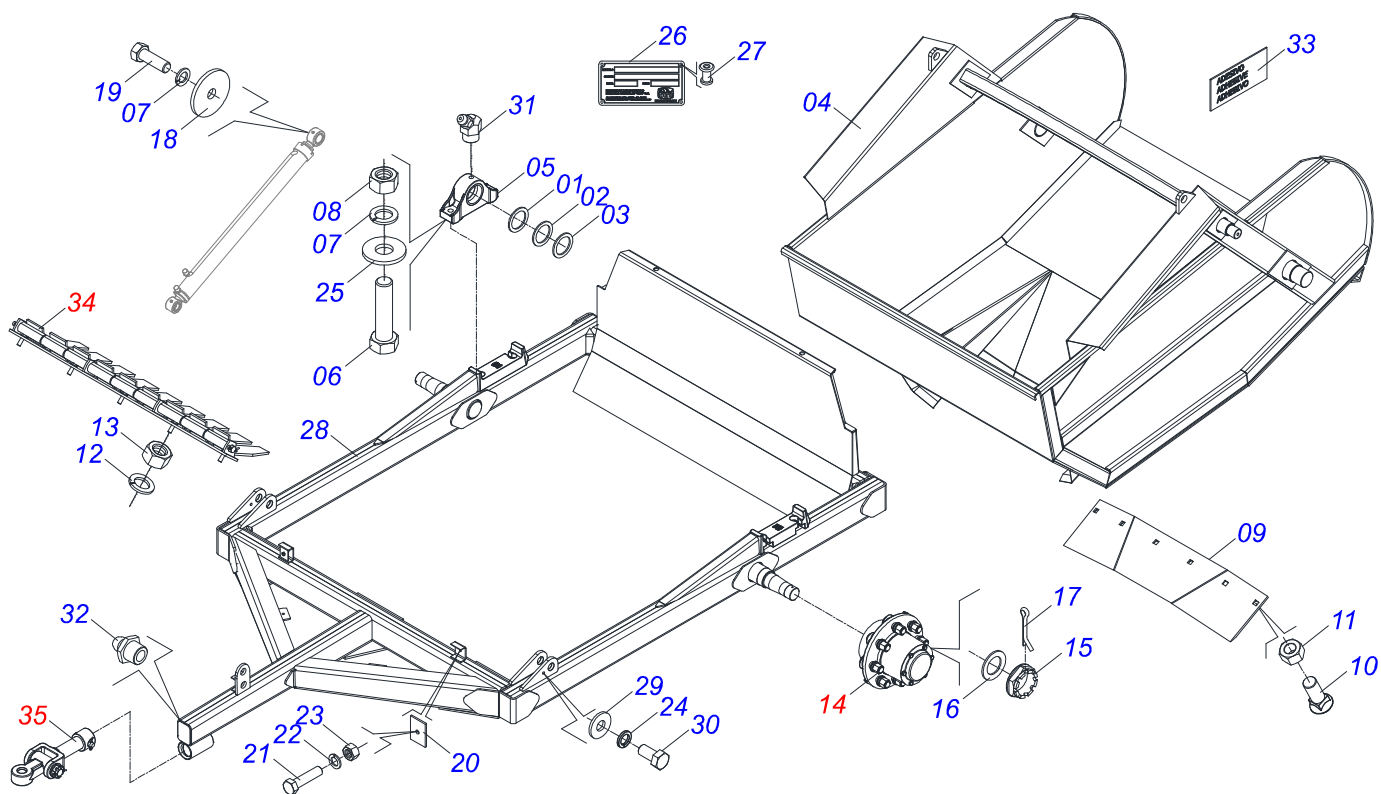

Item	Code	Description	See page	QT
01	0531014846	FLAT WASHER		02
02	0531015317	FLAT WASHER		02
03	0531015318	FLAT WASHER		01
04	0501063307	BUCKET		01
05	0501110081	BEARING ASSY WITH BUSHING		02
06	0501010216	3/4 UNC X 4.1/2 C S G.5 ZN BOLT		04
07	0503011442	3/4" SPRING WASHER		04
08	0503010014	3/4" HEX NUT		08
09	0622360019	SCRAPER STA		01
10	0501012239	5/8" X 1.3/4" BOLT		06
11	0503010013	5/8 NUT		06
12	0503011440	SPRING WASHER		05
13	0503012682	1/2" BSW NUT		05
14	0501051609	ASSY WHEELED BOX	3	02
15	0501010888	1.3/4" 2.5/16" CASTLE NUT		02
16	0591015323	FLAT WASHER 45.50 X 78 X 12.50		02
17	0503010010	1/4" X 2.1/2" COTTERPIN		02
18	0591015757	FLAT WASHER 20 X 78 X 6.30		02
19	0501011544	3/4" X 1-1/2" BOLT		02
20	0501013439	PLATE WITH SUPPORT		03
21	0501010096	3/8" X 2" BOLT		03
22	0503011443	3/8" SPRING WASHER		03
23	0503010026	3/8" NUT		03
24	0503011445	SPRING WASHER		02
25	0501010322	FLAT WASHER		04
26	0503034003	SERIAL NUMBER TAG 61 X 118		01
27	0503010001	3.2 X 5.5 RIVET		04
28	0501063273	FRAME		01
29	0501012140	FLAT WASHER		02
30	0503010962	5/8" X 1-1/4" BOLT		02
31	0503010003	1845 GREASE FITTING		02



STA1
SEMI MOUNTED FRAME

Page 2
0501056361

Item	Code	Description	See page	QT
32	0503010002	1800 GREASE FITTING		01
33	0503060914	ADHESIVE LABEL SET		01
34	0501050226	FLIP ASSY	4	01
35	0511050685	ASSY HITCH	5	01

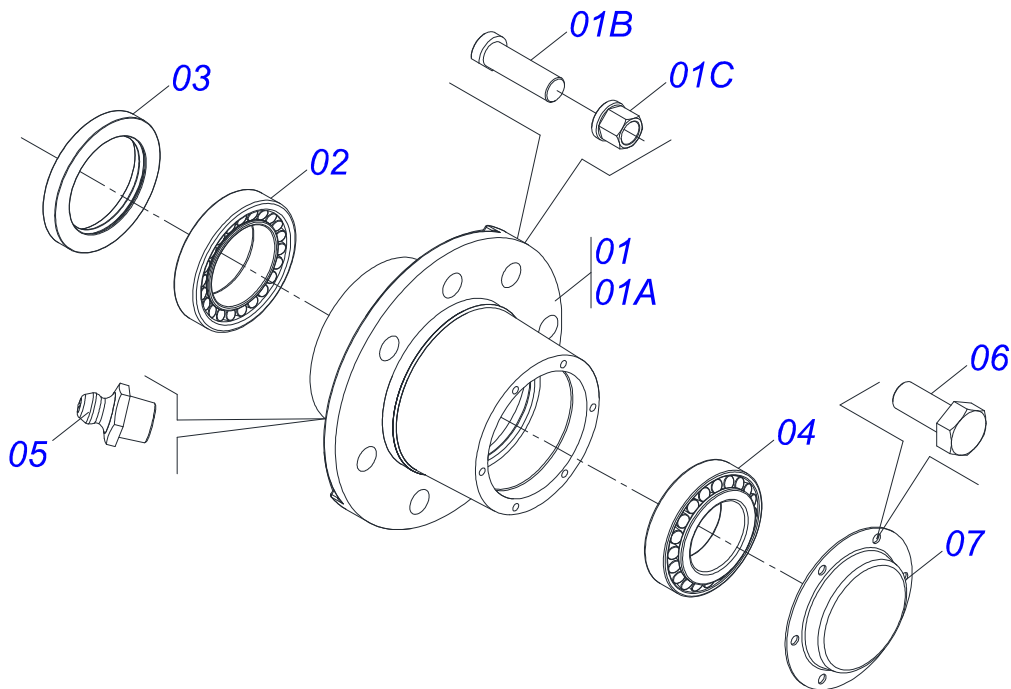

Item	Code	Description	See page	QT
01	0501110744	BOX ROUND WITH SCREW		01
01A	0502011270	WHEEL BOX		01
01B	0501010186	WHEEL SCREW 5/8UNF X 2.1/8CR		06
01C	0503010064	5/8 UNF CONIC NUT		06
02	0503010007	3982/3920 ROLLER BEARING		01
03	0503011866	SEAL 00573-B WITH HOLE		01
04	0503010008	3780/3720 ROLLER BEARING		01
05	0503010002	1800 GREASE FITTING		01
06	0503010295	SCREW 5/16 UNC X 5/8 CS G.2 ZN		01
07	0502020593	COVER		01

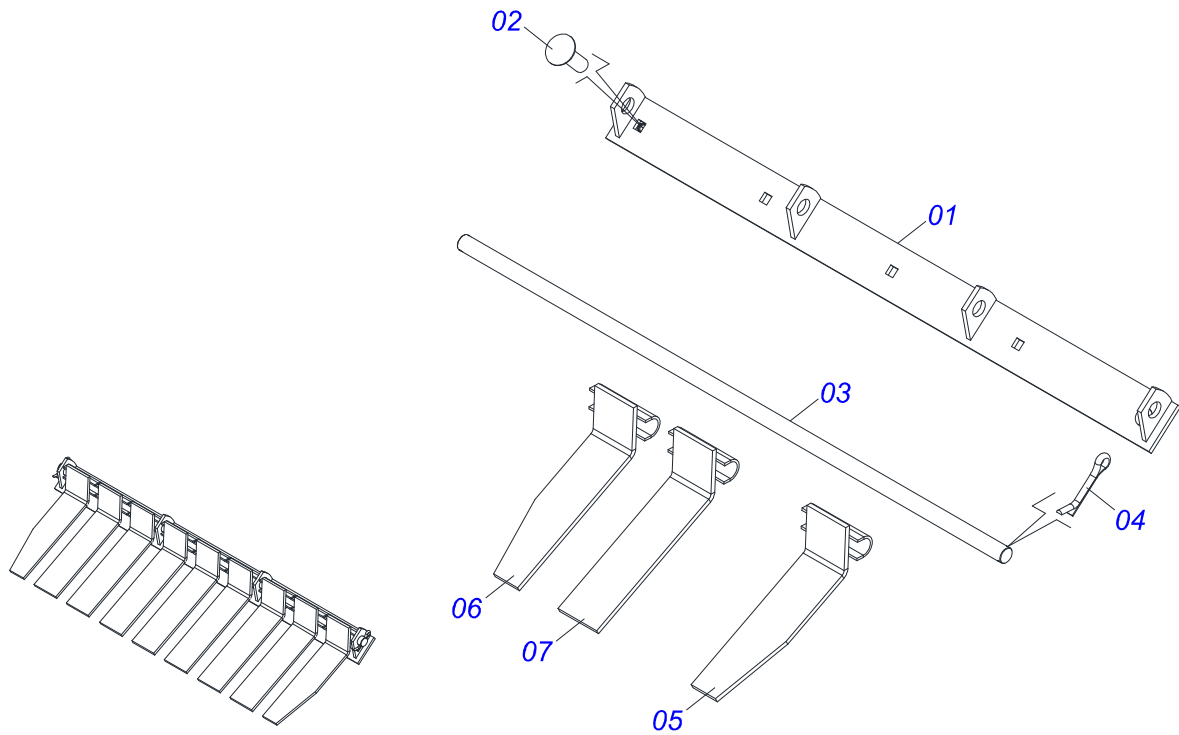

Item	Code	Description	See page	QT
01	0501063158	COVER SUPPORT		01
02	0501010243	1/2" X 1-1/2" BOLT		05
03	0501015053	COVER SHAFT		01
04	0503010571	1/4" X 1.1/2 COTTERPIN		02
05	0501063707	RIGHT SECTION SUPPORT		01
06	0501063706	LEFT SECTION SUPPORT		01
07	0501063159	SECTION SUPPORT		07

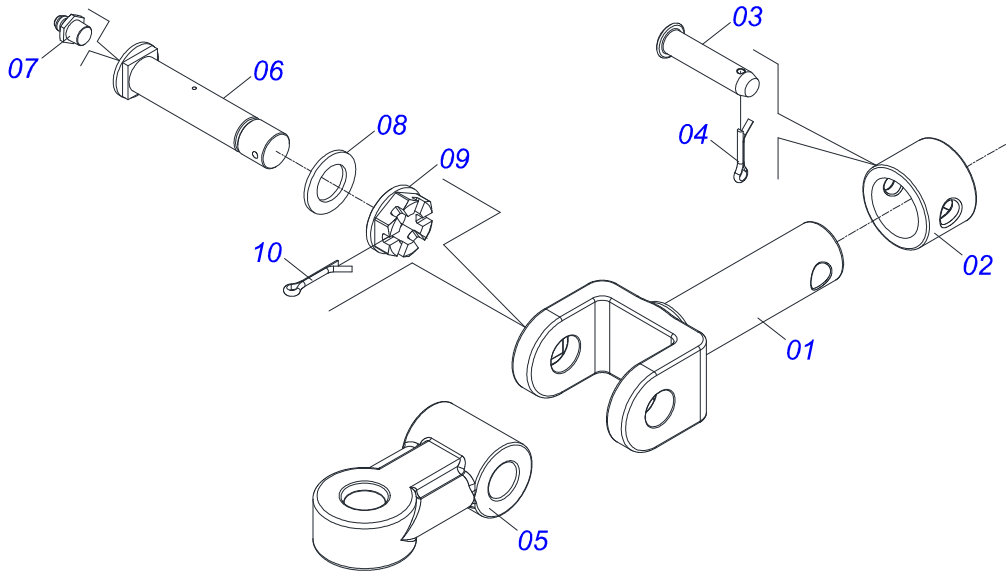

Item	Code	Description	See page	QT
01	1902040822	U HITCH TRACTOR		01
02	1902040327	LOCK SLEEVE		01
03	0521010578	COUPLING SHAFT		01
04	0503010571	1/4" X 1.1/2 COTTERPIN		01
05	1902040821	TRACTOR HITCH BODY		01
06	0521012827	1.5" X 7.4" PIVOT SHAFT		01
07	0503010002	1800 GREASE FITTING		01
08	0501012916	FLAT WASHER 40 X 66 X 4,75 ZN		01
09	0501011301	1.1/2 UNC 6FPP 2.5/16 NUT		01
10	0503010010	1/4" X 2.1/2" COTTERPIN		01

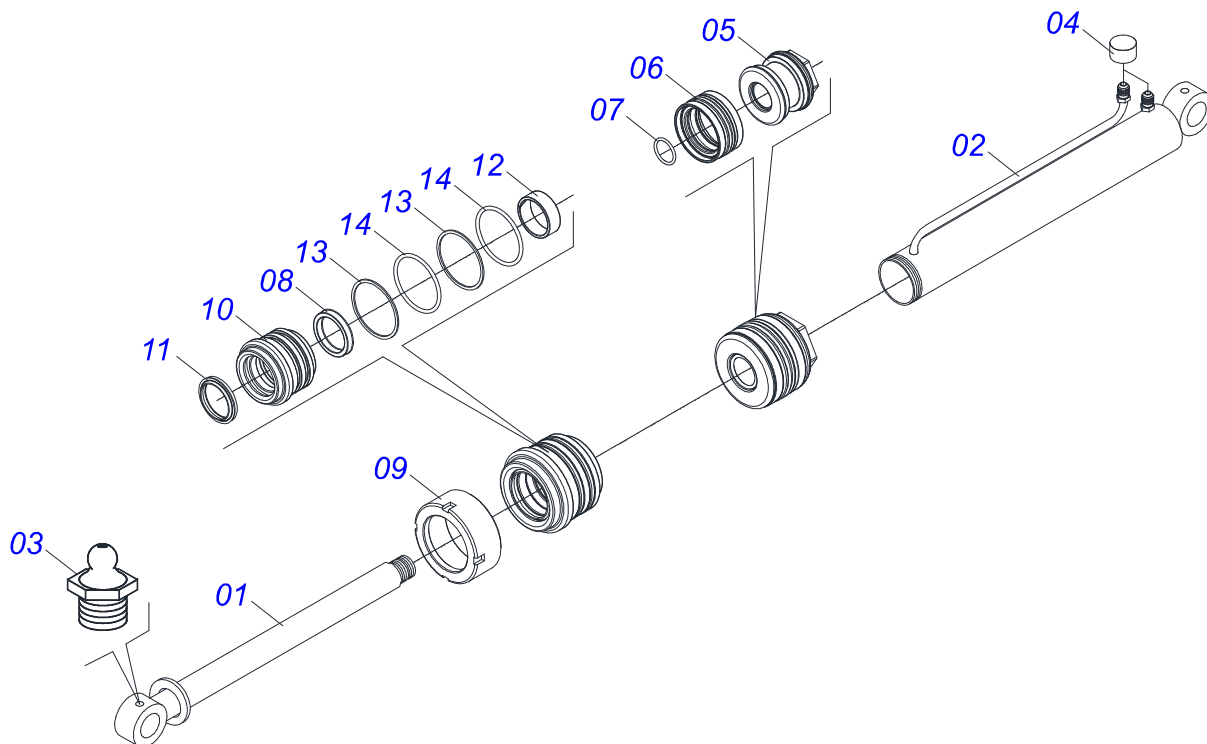

Item	Code	Description	See page	QT
01	0521066634	ROD 38.10 X 890		01
02	0501063282	WELDED CYLINDER		01
03	0503010002	1800 GREASE FITTING		02
04	0503030387	PLUG		02
05	0502012837	PISTON		01
06	0503018005	RING		01
07	0503011109	2-119 N 3006-9B O'RING		01
08	0503010163	D-1500 SCRAPER RING		01
09	0502010471	63,50 MOBILE CAP		01
10	0581010668	RING SUPPORT		01
11	0503018004	RING		01
12	0503018003	GASKET		01
13	0503018163	BACK-UP RING		02
14	0503018162	O'RING		02

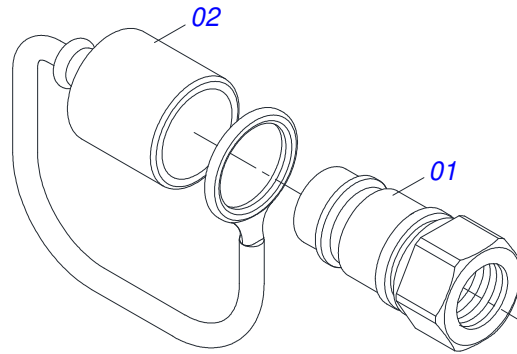

Item	Code	Description	See page	QT
01	0503011627	MALE QUICK COUPLER AGR 1/2 NPT		01
02	0503011882	MALE QUICK COUPLER CAP		01

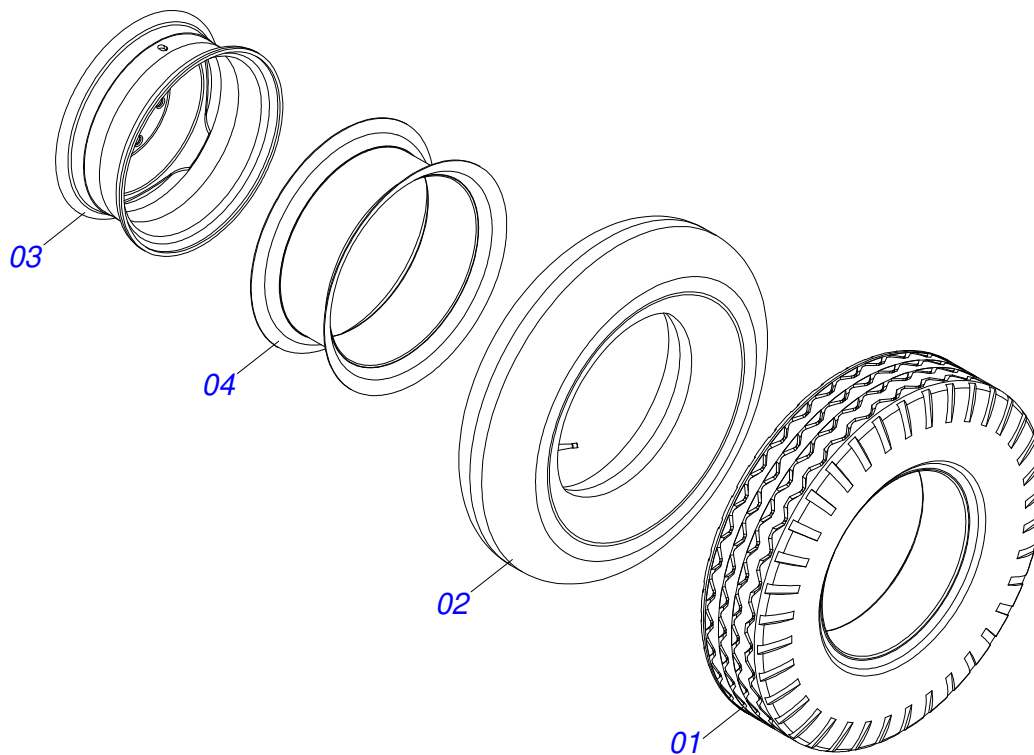

Item	Code	Description	See page	QT
01	0503010494	9.0LX 20" X 14 PLY, TIRE		01
02	0503010057	INNER TIRE		01
03	0501063939	2.6"X0.8"X5.1"X 6F0.75"X6.8" WHEEL		01
04	0503010470	PROTECTION		01



MARCHESAN

Technical Publications | Elaboration and Revision
JOSÉ DOMINGOS GASPARI

www.marchesan.com.br

