

PARTS CATALOG

SUBSOILER PLOW

AST/MATIC 450/450E_500_550E

Code: 0501090763



Series: S-0905

Review: SETEMBRO/2007

ORIGINAL PARTS
TATU



INDEX

MOUNTED DISC ASTMATIC 450/450E	1
44,45 X 85,7 X 515 X 203 HYDRAULIC CYLINDER	2
HYDRAULIC CYLINDER 203 BP	3
CARRYING-WHEEL ASSY	4
BLADE DISC ASSY	5
BLADE DISC ASSY E 450 S-0400	6
SHANKS SYSTEM ASSY AST/MATIC 450	7
SHANKS SYSTEM ASSY	8
7.5" X 1-1/4" OIL BATH BEARING	9
7.5" X 1-1/4" OIL BATH BEARING	10
HYDRAULIC CIRCUIT 450/450E	11
AST/MATIC 500	12
HYDRAULIC CYLINDER	13
HYDRAULIC CYLINDER	14
FURROW WHEEL RIGHT SUPPORT	15
LH SUPPORT STUB SHAFT & HUB	16
SHANKS SYSTEM ASSY	17
SHANKS SYSTEM ASSY	18
HIDRAULIC CIRCUIT	19
ASTMATIC 550	20
2.0" X 4" X 22" X 10" HYDRAULIC CYLINDER	21
1.7" X 3.4 "X 22" X 10" HYDRAULIC CYLINDER	22
BLADE DISC ASSYAST/MATIC E550 S0203	23
FRONT BLADE DISC ASSY	24
REAR BLADE DISC ASSY	25
SHANKS SYSTEM ASSY AST/MATIC 450	26
SHANKS SYSTEM ASSY	27
SHANKS SYSTEM ASSY	28
SHANKS SYSTEM	29
STAC 5HE DC RD	30
	31
HYDRAULIC CYLINDER	33
BLADE DISC ASSY	34
HYDRAULIC CYLINDER	36
AGR DM OL 225X 1.1/2 BEARING ASSY	37

ATTENTION: **IMPORTANT**

MARCHESAN RESERVES THE RIGHT AT ANY TIME TO MAKE IMPROVEMENTS IN THE DESIGN, MATERIAL OR SPECIFICATIONS OF MACHINERY, EQUIPMENT OR PARTS WITHOUT THEREBY BECOMING LIABLE TO MAKE SIMILAR CHANGES IN MACHINERY, EQUIPMENT OR PARTS PREVIOUSLY SOLD.

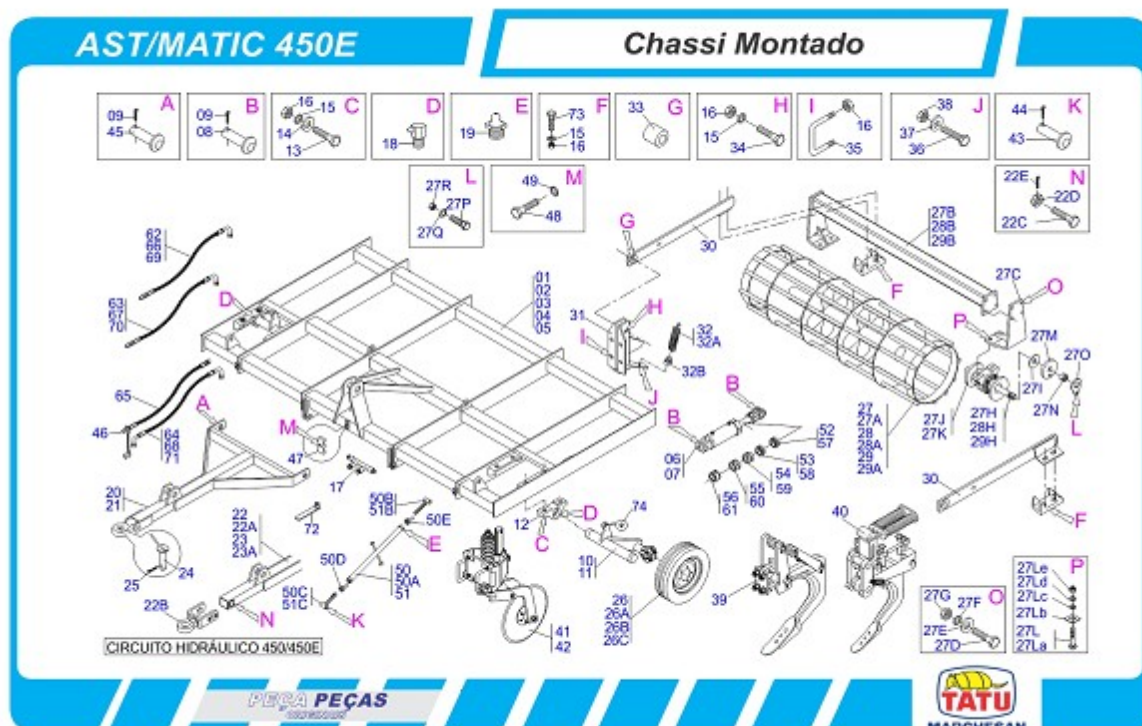

Item	Code	Description	05	07	09	11	13
01	0501067778	AST/MATIC 5 FRAME	01	00	00	00	00
02	0501067779	AST/MATIC 7 FRAME	00	01	00	00	00
03	0501067780	AST/MATIC 9 FRAME	00	00	01	00	00
04	0501067781	AST/MATIC 11 FRAME	00	00	00	01	00
05	0511061907	FRAME	00	00	00	00	01
06	0511043790	44,45 X 85,7 X 515 X 203 HYDRAULIC CYLINDER	01	01	01	01	01
07	0511043786	HYDRAULIC CYLINDER 203 BP	01	01	01	01	01
08	0521012538	1.2" X 3.5" COUPLING SHAFT	04	04	04	04	04
09	0503010523	1/4" X 2" COTTERPIN	08	08	08	08	08
10	0501051007	RIGHT STUB SHAFT & HUB ASSY	01	01	01	01	01
11	0501051008	LEFT STUB SHAFT & HUB ASSY	01	01	01	01	01
12	0501110563	LH PIVOT BEARING	02	02	02	02	02
12A	0502012273	PIVOT BEARING	04	04	04	04	04
12B	0551018339		04	04	04	04	04
13	0503010901	3/4" X 3-1/2" BOLT	08	08	08	08	08
14	0501010322	FLAT WASHER	08	08	08	08	08
15	0503011442	3/4" SPRING WASHER	34	40	40	40	40
16	0503010014	3/4" NUT	34	40	40	40	40
17	0501110568	WHEEL PIVOT BEARING	02	02	02	02	02
17A	0502012509		02	02	02	02	02
18	0501068088	OIL TUBE	01	01	01	01	01
19	0503010002	GREASE FITTING	04	04	04	04	04
20	0501067791	DRAWBAR	01	01	01	00	00
21	0501069655	DRAWBAR	00	00	00	01	00
22	0501048294	DRAWBAR ASSY	00	00	00	01	00
22A	0501069685	DRAWBAR	00	00	00	01	00
22B	0501069684	TRACTOR HITCH	00	00	00	01	01
22C	0501017291	1-1/2" X 8.1" BOLT	00	00	00	01	01
22D	0501011301	1.1/2" CASTLE NUT	00	00	00	01	01
22E	0503010010	1/4" X 2.1/2" COTTERPIN	00	00	00	01	01
23	0511040026	DRAWBAR ASSY	00	00	00	00	01
23A	0511062392	DRAWBAR	00	00	00	00	01
24	0501066637	DRAWBOLT	01	01	01	01	01



MOUNTED DISC ASTMATIC 450/450E

0909091339

Item	Code	Description	05	07	09	11	13
25	0503010534	3/8" X 2-1/2" COTTERPIN	01	01	01	01	01
26	0503060091	29.5"X0.63"-10L WHEEL AND TIRE ASSY	02	02	02	02	02
26A	0503010893	0.22" X 0.63" WHEEL	02	02	02	02	02
26B	0503010033	7.50 X 16 INNER TIRE	02	02	02	02	02
26C	0503010120	CANVAS TIRE	02	02	02	02	02
27	0501055243	ARM ROLLE ASSY	01	00	00	02	01
27A	0511065382	2108 BREAK ROLLER	01	00	00	02	01
27B	0511065379	2129 BREAK ROLLER SUPPORT	01	00	00	02	01
27C	0511064543	BREAK ROLLER BRACKET	01	01	01	01	01
27D	0501010100	5/8" X 2" BOLT	04	04	04	04	04
27E	0501012140	FLAT WASHER	04	04	04	04	04
27F	0503011445	5/8" SPRING WASHER	04	04	04	04	04
27G	0503010013	5/8" NUT	04	04	04	04	04
27H	0501013310	1-1/4 X 2150 AXLE	01	00	00	02	01
27I	0531018575	WASHER CONCAVE	02	02	02	02	02
27J	0501046922	7.5" X 1-1/4" OIL BATH BEARING	01	01	01	01	01
27K	0501042180	7.5" X 1-1/4" OIL BATH BEARING	01	01	01	01	01
27L	0501048788	5/8" X 2-1/2" BOLT ASSY	04	04	04	04	04
27La	0501014177	5/8" X 2-1/2" BOLT	01	01	01	01	01
27Lb	0501010947	5/8" SQUARE WASHER	01	01	01	01	01
27Lc	0501012140	FLAT WASHER	01	01	01	01	01
27Ld	0503011445	5/8" SPRING WASHER	01	01	01	01	01
27Le	0503010013	5/8" NUT	01	01	01	01	01
27M	0502010835	1-1/4" EXTERNAL AXLE WASHER	02	02	02	02	02
27N	0501010087	1.1/4" UNC NUT	02	02	02	02	02
27O	0501010455	1-1/4" 2.04" NUT LOCK	02	02	02	02	02
27P	0501010161	1/2" X 1-1/4" BOLT	02	02	02	02	02
27Q	0503011440	1/2" SPRING WASHER	05	05	05	05	05
27R	0503010060	1/2" NUT	02	02	02	02	02
28	0501055244	BOX BREAK ROLLER	00	02	00	00	02
28A	0511065383	BREAK ROLLER 1310	00	02	00	00	02
28B	0511065380	BREAK ROLLER 1329	00	01	00	00	02
28H	0541011902	1.1/4 X 1355 AXLE	00	01	00	00	02
29	0501055245	BREAK ROLLER ASSY	00	00	01	00	00
29A	0511065384	1710 BREAK ROLLER	00	00	01	00	00
29B	0511065381	1729 BREAK ROLLER SUPPORT	00	00	01	00	00
29H	0541011903	1.1/4" X 1755 AXLE	00	00	01	00	00
30	0511065378	BREAK ROLLER ARM	02	02	02	02	02
31	0501068437	BREAK ROLLER SUPPORT FIXATION	02	02	02	02	02
32	0501053355	HITCH TRACTION SPRING	02	02	02	02	02
32A	0503030806	2.3" X 8" X 0.3" TRACTION SPRING	02	02	02	02	02
32B	0502011060	SUPPORT SPRING	02	02	02	02	02
33	0511018178	1.2" X 0.8" X 0.7" BUSHING	02	02	02	02	02
34	0501010827	3/4" X 2-3/4" BOLT	02	02	02	02	02
35	0521014574	3/4" X 6.3" X 5.1" FASTENE	14	14	14	14	14
36	0503011264	1/2" X 2-1/2" BOLT	02	02	02	02	02
37	0511017302	FLAT WASHER	02	02	02	02	02
38	0503010060	1/2" NUT	02	02	02	02	02
39	0501046935	SHANKS SYSTEM ASSY AST/MATIC 450	05	07	09	11	13
40	0501049402	SHANKS SYSTEM ASSY	05	07	09	11	13
41	0511042280	BLADE DISC ASSY E 450 S-0400	05	07	09	11	13
42	0501053707	BLADE DISC ASSY	05	07	09	11	13
43	0521010579	0.9" X 4.5" COUPLING SHAFT	02	02	02	02	02
44	0503010571	1/4" X 1.1/2" COTTERPIN	08	08	08	08	08
45	0521010596	1.1" X 4.7" COUPLING SHAFT	02	02	02	02	02
46	0501053834	QUICK CONECTION (MALE) 1/2NPT	02	02	02	02	02
47	0502010477	UPPER CLAMP BODY	03	03	03	03	03
48	0503010751	3/8" X 1.1/4" HEX BOLT G.5	03	03	03	03	03
49	0503010025	3/8" SPRING WHASHER	03	03	03	03	03
50	0501047356	ESTABILIZER ASSY	01	01	01	01	01
50A	0501068095	850 ADJUSTMENT NUT	01	01	01	01	01
50B	0501068096	RIGH TURNBUCLE	01	01	01	01	01



AST/MATIC 450/450E_500_550E
MOUNTED DISC ASTMATIC 450/450E

Item	Code	Description	05	07	09	11	13
50C	0501068097	LEFT TURNBUCKLE	01	01	01	01	01
50D	0541018673	LOCKNUT WITH LEFT R 2-1/2"	01	01	01	01	01
50E	0541018672	LOCKNUT WITH RIGHT HANDLER R 1-1/2"	01	01	01	01	01
51	0501052930	ESTABILIZER DRAWBAR ASSY	01	01	01	01	01
51B	0511062394	RH JACK CRANK	01	01	01	01	01
51C	0511062395	LEFT TURNBUCKLE	01	01	01	01	01
52	0501047884	0.98" ROD STOP	01	01	01	01	01
53	0501047885	1.18" ROD STOP	01	01	01	01	01
54	0501047886	1.38" ROD STOP	01	01	01	01	01
55	0501047887	1.57" ROD STOP	01	01	01	01	01
56	0501047889	1.96" ROD STOP	01	01	01	01	01
57	0501052862	0.98" ROD STOP	01	01	01	01	01
58	0501052863	1.18" ROD STOP	01	01	01	01	01
59	0501052864	1.38" ROD STOP	01	01	01	01	01
60	0501052865	1.57" ROD STOP	01	01	01	01	01
61	0501052866	1.96" ROD STOP	01	00	00	00	00
62	0501080386	3/8" X 41" TR-TC HOSE ASSY	01	00	00	00	00
63	0501080302	3/8" X 51" TR-TC HOSE ASSY	01	00	00	00	00
64	0501080370	3/8" X 95" TC-TC HOSE ASSY	01	00	00	00	00
65	0501080384	3/8" X 118" TR-TM HOSE ASSY	01	01	01	01	01
66	0501080025	3/8" X 55" TR-TC HOSE ASSY	00	01	00	01	00
67	0501080402	3/8" X 67" TR-TC HOSE ASSY	00	01	00	01	00
68	0501080479	3/8" X 120" TC-TC HOSE ASSY	00	01	00	01	00
69	0501080431	3/8" X 75" TR-TC HOSE ASSY	00	00	01	00	00
70	0501080419	3/8" X 83" TR-TC HOSE ASSY	00	00	01	00	00
71	0501080578	3/8" X 157" TC-TC HOSE ASSY	00	00	01	00	01
72	0501061617	1" WRENCH CYLINDRICAL HEX	01	01	01	01	01
73	0501010216	3/4" X 4-1/2" BOLT	04	04	04	04	04
74	0511019920	1.5" X 0.1" X 1" SLEEVE	02	02	02	02	02

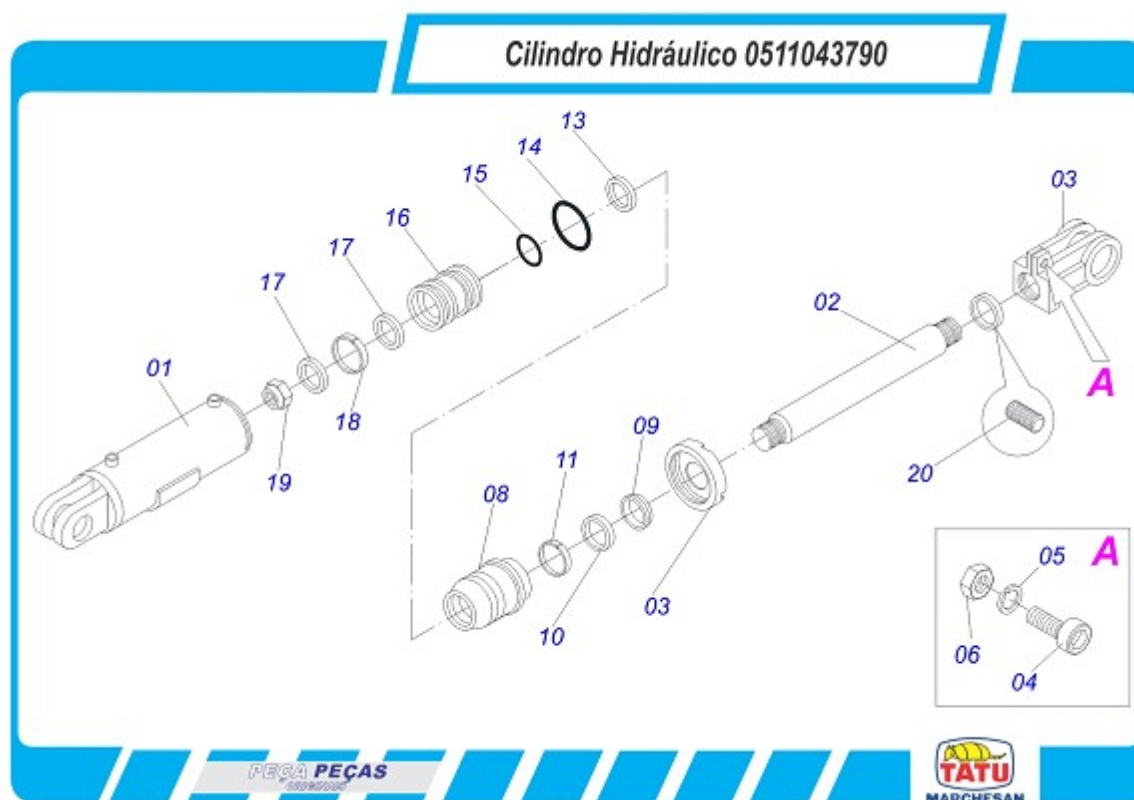

Item	Code	Description	
00	0511043790	44,45 X 85,7 X 515 X 203 HYDRAULIC CYLINDER	
01	0511066433	85,72 X 203 CYLINDER CASE	01
02	0521010421	HYDRAULIC CILYNDER TURNBUCLE	01
03	0502040747	FORK	01
04	0503011094	3/8" X 2" BOLT C C S I 12.9	01
05	0503010025	3/8" SPRING WHASHER	01
06	0503010026	3/8" NUT	01
07	0502010993	DETACHABLE COVER	01
08	0502010781	RING SUPPORT	01
09	0503010761	D-1750 SCRAPER RING	01
10	0503010990	GASKET	01
11	0503010949	W2-2000-500 PK RING G.E	01
12	0511018115	1.8" X 0.1" 0.7" BUSHING	01
13	0503011060	8-336 BACK-UP RING	01
14	0503010976	2-336 N 3006-9B O'RING	01
15	0503010042	2-214 N 3006-9B O'RING	01
16	0502011847	1.7" X 3.4" PISTON	01
17	0503012509	GASKET	02
18	0503010948	W4-3346-590 PK RING G.E	01
19	0503010063	1" SELF-ALIGNING NUT	01
20	0503011148	3/8" X 1/2" BOLT	01

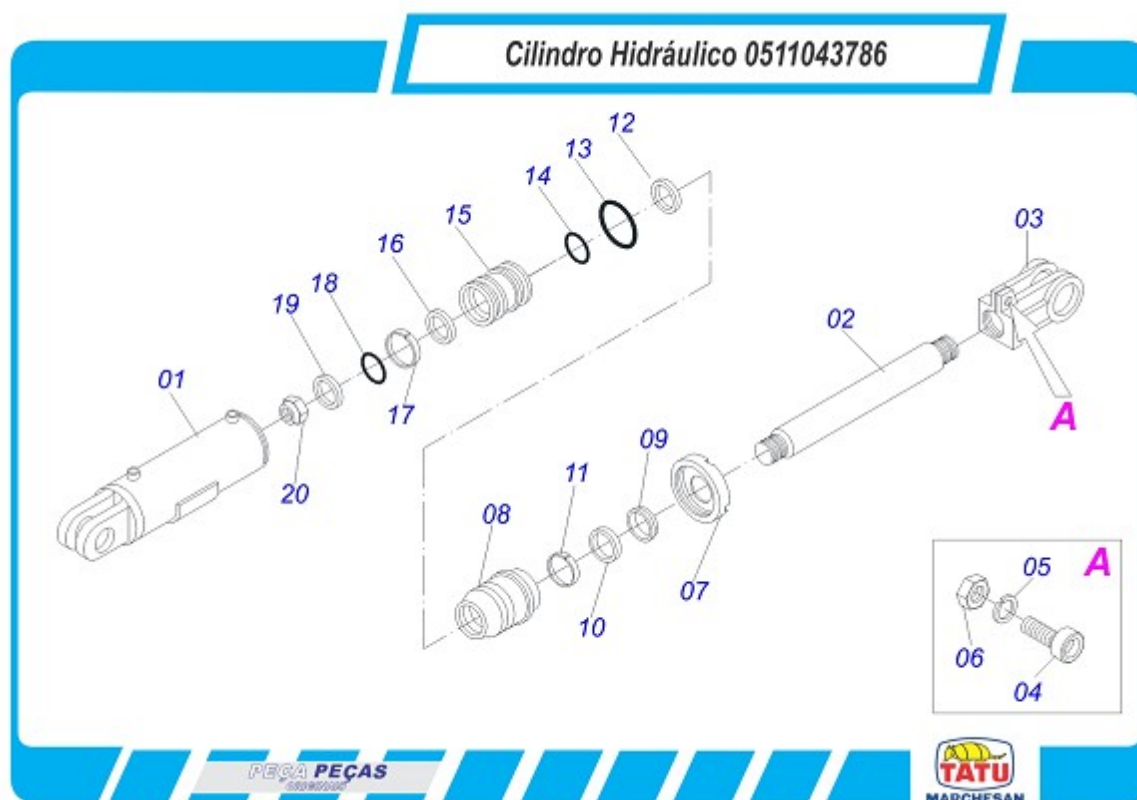

Item	Code	Description	
00	0511043786	HYDRAULIC CYLINDER 203 BP	
01	0511066641	4" X 7.9" CYLINDER CASE	01
02	0531018245	EXTENDING BODY	01
03	0502040747	FORK	01
04	0503011094	3/8" X 2" BOLT C C S I 12.9	01
05	0503010025	3/8" SPRING WHASHER	01
06	0503010026	3/8" NUT	01
07	0502010017	4" HEAD	01
08	0502011250	2.1 X 4" RING SUPPORT	01
09	0503010319	D-2125 SCRAPER	01
10	0503010314	GASKET	01
11	0503010973	W2-2500-500 PK RING G.E	01
12	0503011061	8-342 BACK-UP RING	01
13	0503010338	2-342 N 3006-9B O'RING	01
14	0503010345	2-218 N 3006-9B O'RING	01
15	0502011249	2.1 X 4" PISTON	01
16	0503010043	PACKING 3750-3250	01
17	0503010994	W2-4000-500 PK RING G.E	01
18	0503012726	RUBBER RING	01
19	0503012725	GASKET	01
20	0503010817	1.1/4" UNF SELF ADJUSTING NUT	01

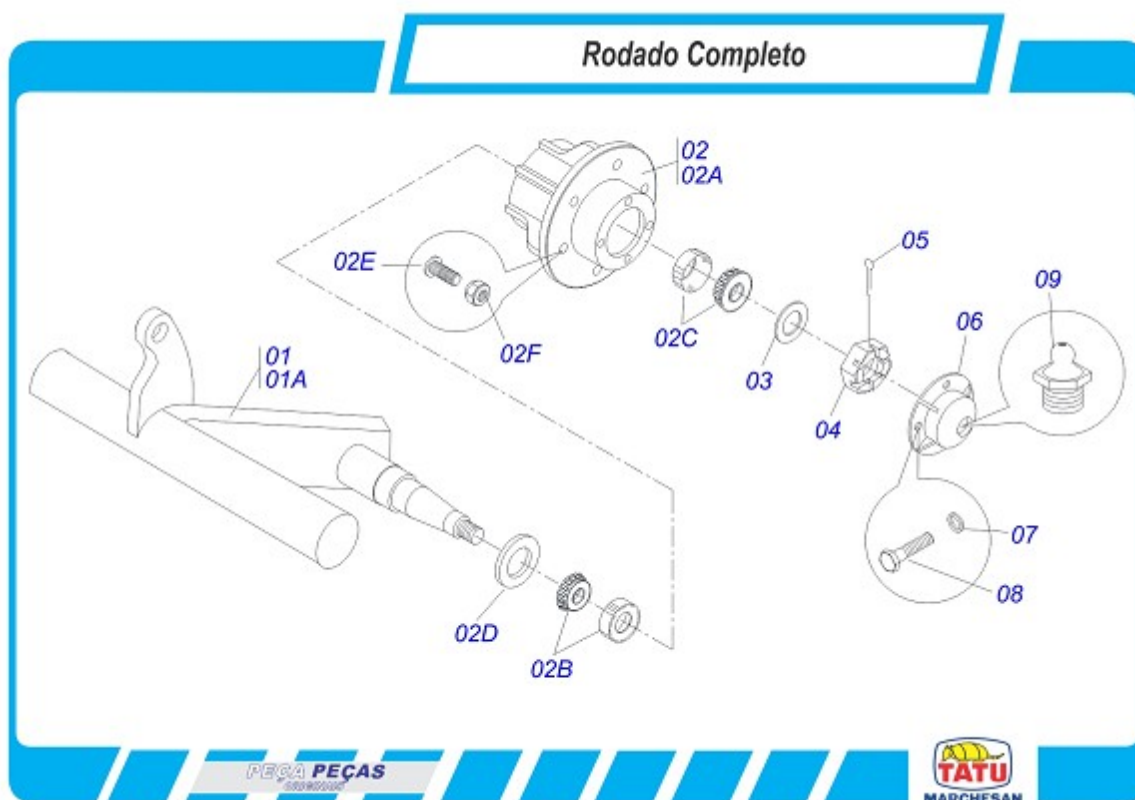

Item	Code	Description	
00	0501051007	RIGHT STUB SHAFT & HUB ASSY	
00A	0501051008	LEFT STUB SHAFT & HUB ASSY	
01	0501068416	RIGH TH DEPTH CONTROL	01
01A	0501068417	LEFT DEPTH CONTROL	01
02	0501051142	CARRYING WHEEL HUB	01
02A	0502011121	CARRYING WHEEL HUB	01
02B	0503010006	32210 ROLLER BEARING	01
02C	0503010037	30207 ROLLER BEARING	01
02D	0503011867	00517-BR SEAL WITH HOLE	01
02E	0501010127	9/16" X 1-7/8" LUG BOLT	06
02F	0503010035	9/16" CONIC NUT	06
03	0501016545	FLAT WASHER	01
04	0503030009	1" X 0.9" CASTLE NUT	01
05	0503010018	5/32" X 1-1/2" COTTERPIN	01
06	0502020591	COVER	01
07	0503010179	5/16" SPRING WASHER	04
08	0503010178	5/16" X 7/8" BOLT	04
09	0503010002	GREASE FITTING	01

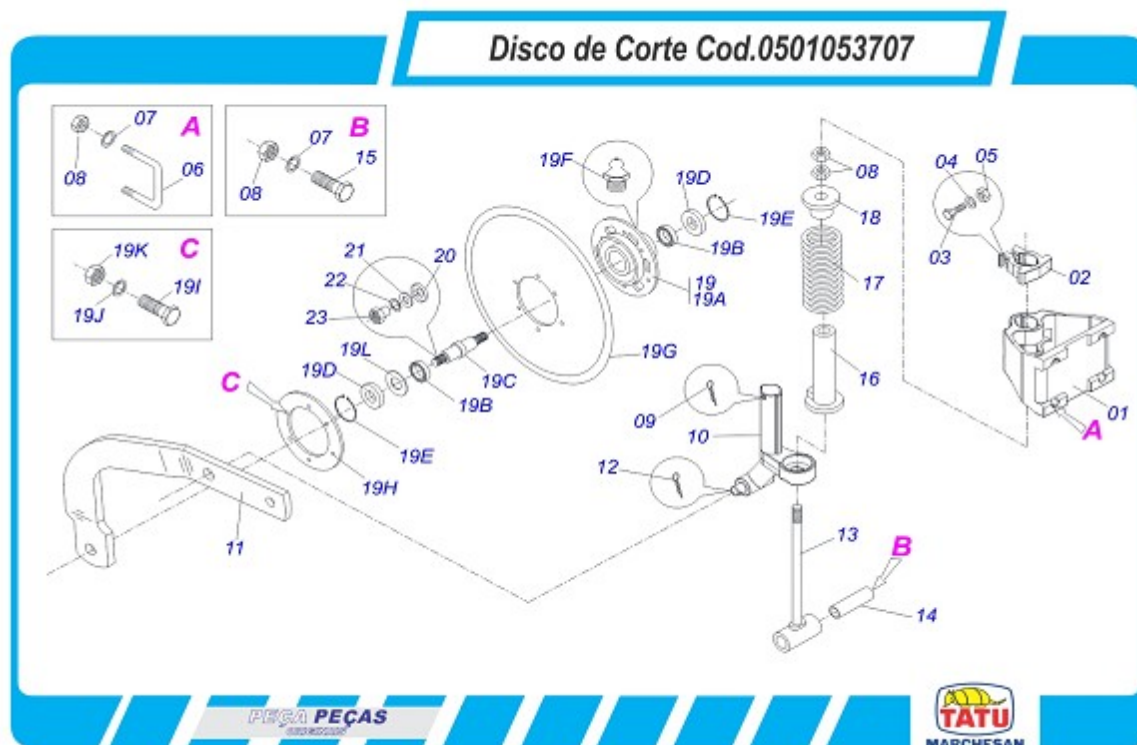

Item	Code	Description	
00	0501053707	BLADE DISC ASSY	05 07 09 11 13
01	0502012026	BLADE DISC FIXER SUPPORT	05 07 09 11 13
02	0502012024	FIXER SUPPORT BUSHING	05 07 09 11 13
03	0503011067	5/8" X 2-1/2" BOLT	05 07 09 11 13
04	0501011299	FLAT WASHER	05 07 09 11 13
05	0503010129	5/8" NUT	05 07 09 11 13
06	0521010660	3/4" X 5.9" X 5.1" HOLDER	05 07 09 11 13
07	0503010023	3/4" SPRING WASHER	05 07 09 11 13
08	0503010014	3/4" NUT	05 07 09 11 13
09	0503010534	3/8" X 2-1/2" COTTERPIN	05 07 09 11 13
10	0502012025	BLADE DISC SUPPORT	05 07 09 11 13
11	0521019800	BLADE DISC BREAK	05 07 09 11 13
12	0503010571	1/4" X 1.1/2" COTTERPIN	05 07 09 11 13
13	0511060915	SPRING REGULATOR	05 07 09 11 13
14	0521010452	0.8" X 1" X 3.3" SLEEVE	05 07 09 11 13
15	0501010370	3/4" X 5-1/2" BOLT	05 07 09 11 13
16	0511061576	SPRING GUIDE	05 07 09 11 13
17	0503031679	3" X 13" X 0.4" COMPRESSION SPRING	05 07 09 11 13
18	0502020393	SPRING UPPER SUPPORT	05 07 09 11 13
19	0501052139	18 BLADE DISC WITH FLAT PLAN DISC	05 07 09 11 13
19A	0502011562	DC PST ACT/ULTR BOX	05 07 09 11 13
19B	0503010276	6206 BALL BEARING	05 07 09 11 13
19C	0521013610	BLADE DISC HUB AXLE	05 07 09 11 13
19D	0503012417	SEAL 05175-GY	05 07 09 11 13
19E	0503011800	502062 CLAMPING RING (FOR AXLE)	05 07 09 11 13
19F	0503010691	1/4" GREASE FITTING	05 07 09 11 13
19G	0603026013	18"X 0.2" PLAIN COULTER BLADE,LETF	05 07 09 11 13
19H	0502020641	BLADE DISC FLANGE	05 07 09 11 13
19I	0503010363	5/16" X 1" BOLT	05 07 09 11 13
19J	0503011444	5/16" SPRING WASHER	05 07 09 11 13
19K	0503010337	5/16" NUT	05 07 09 11 13
19L	0503030832	FLAT WASHER	05 07 09 11 13
20	0521015376	DUST CLOAK	05 07 09 11 13



BLADE DISC ASSY

0501053707

Item	Code	Description	
21	0511015346	FLAT WASHER	05 07 09 11 13
22	0503011438	1" SPRING WASHER	05 07 09 11 13
23	0521013510	3/4" AXLE DISC BLADE NUT	05 07 09 11 13

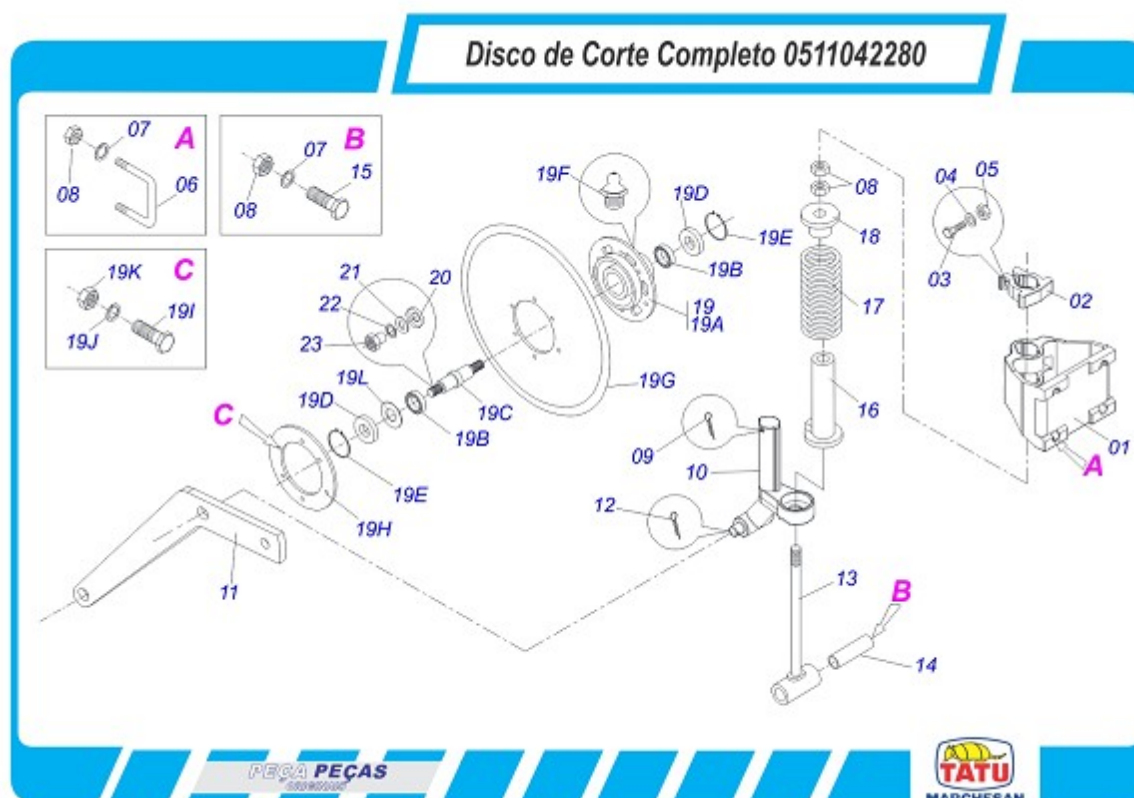

Item	Code	Description	05	07	09	11	13
00	0511042280	BLADE DISC ASSY E 450 S-0400	05	07	09	11	13
01	0502012026	BLADE DISC FIXER SUPPORT	05	07	09	11	13
02	0502012024	FIXER SUPPORT BUSHING	05	07	09	11	13
03	0503013184	5/8" X 2-3/4" BOLT G.8	05	07	09	11	13
04	0501011299	FLAT WASHER	05	07	09	11	13
05	0503010129	5/8" NUT	05	07	09	11	13
06	0521010660	3/4" X 5.9" X 5.1" HOLDER	05	07	09	11	13
07	0503010023	3/4" SPRING WASHER	05	07	09	11	13
08	0503010014	3/4" NUT	05	07	09	11	13
09	0503010534	3/8" X 2-1/2" COTTERPIN	05	07	09	11	13
10	0502012025	BLADE DISC SUPPORT	05	07	09	11	13
11	0541010152	BLADE DISC BREAK	05	07	09	11	13
12	0503010571	1/4" X 1.1/2" COTTERPIN	05	07	09	11	13
13	0511060915	SPRING REGULATOR	05	07	09	11	13
14	0521010452	0.8" X 1" X 3.3" SLEEVE	05	07	09	11	13
15	0501010370	3/4" X 5-1/2" BOLT	05	07	09	11	13
16	0511061576	SPRING GUIDE	05	07	09	11	13
17	0503031679	3" X 13" X 0.4" COMPRESSION SPRING	05	07	09	11	13
18	0502020393	SPRING UPPER SUPPORT	05	07	09	11	13
19	0501052139	18 BLADE DISC WITH FLAT PLAN DISC	05	07	09	11	13
19A	0502011562	DC PST ACT/ULTR BOX	05	07	09	11	13
19B	0503010276	6206 BALL BEARING	05	07	09	11	13
19C	0521013610	BLADE DISC HUB AXLE	05	07	09	11	13
19D	0503012417	SEAL 05175-GY	05	07	09	11	13
19E	0503011800	502062 CLAMPING RING (FOR AXLE)	05	07	09	11	13
19F	0503010691	1/4" GREASE FITTING	05	07	09	11	13
19H	0502020641	BLADE DISC FLANGE	05	07	09	11	13
19I	0503010371	5/16" X 1" BOLT	05	07	09	11	13
19J	0503011444	5/16" SPRING WASHER	05	07	09	11	13
19K	0503010337	5/16" NUT	05	07	09	11	13
19L	0503030832	FLAT WASHER	05	07	09	11	13
20	0521015376	DUST CLOAK	05	07	09	11	13
21	0511015346	FLAT WASHER	05	07	09	11	13



Item	Code	Description	05	07	09	11	13
22	0503011438	1" SPRING WASHER	05	07	09	11	13
23	0521013510	3/4" AXLE DISC BLADE NUT	05	07	09	11	13

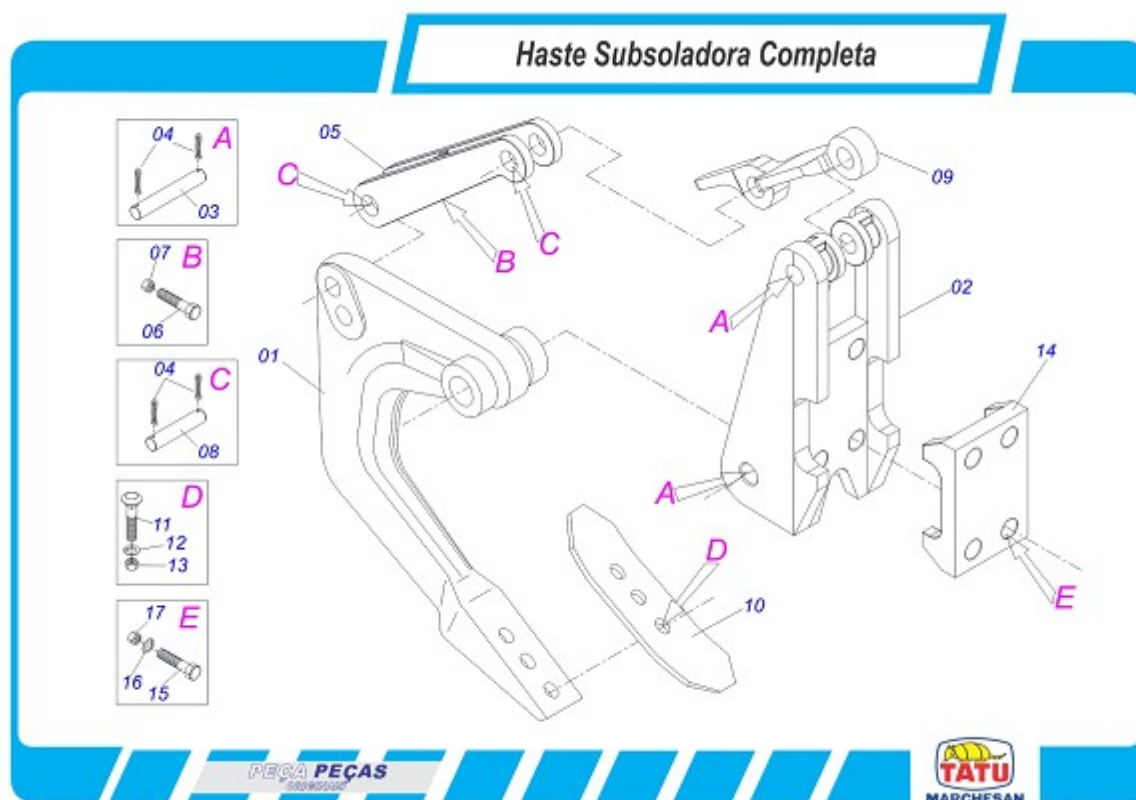

Item	Code	Description	
00	0501046935	SHANKS SYSTEM ASSY AST/MATIC 450	01
01	0502011264	ARM AST/MATIC	01
02	0502011165	REAR FIXER	01
03	0511015688	1.1" X 7.1" COUPLING SHAFT	02
04	0503010571	1/4" X 1.1/2" COTTERPIN	08
05	0502011164	SUPPORT SPRING	01
06	0503011173	7/16" X 2" BOLT	01
07	0503010244	7/16" NUT	01
08	0511015689	1.1" X 3.5" COUPLING SHAFT	02
09	0521011631	AUTOMATIC RESET	01
10	0624010005	POINT SUBSOILER	01
11	0501010078	1/2" X 1-1/2" BOLT	03
12	0503011440	1/2" SPRING WASHER	03
13	0503010020	1/2" NUT	03
14	0502011166	FRONT FIXER	01
15	0511019527	1" X 8" BOLT	04
16	0503011438	1" SPRING WASHER	04
17	0503010340	1" UNF NUT	04

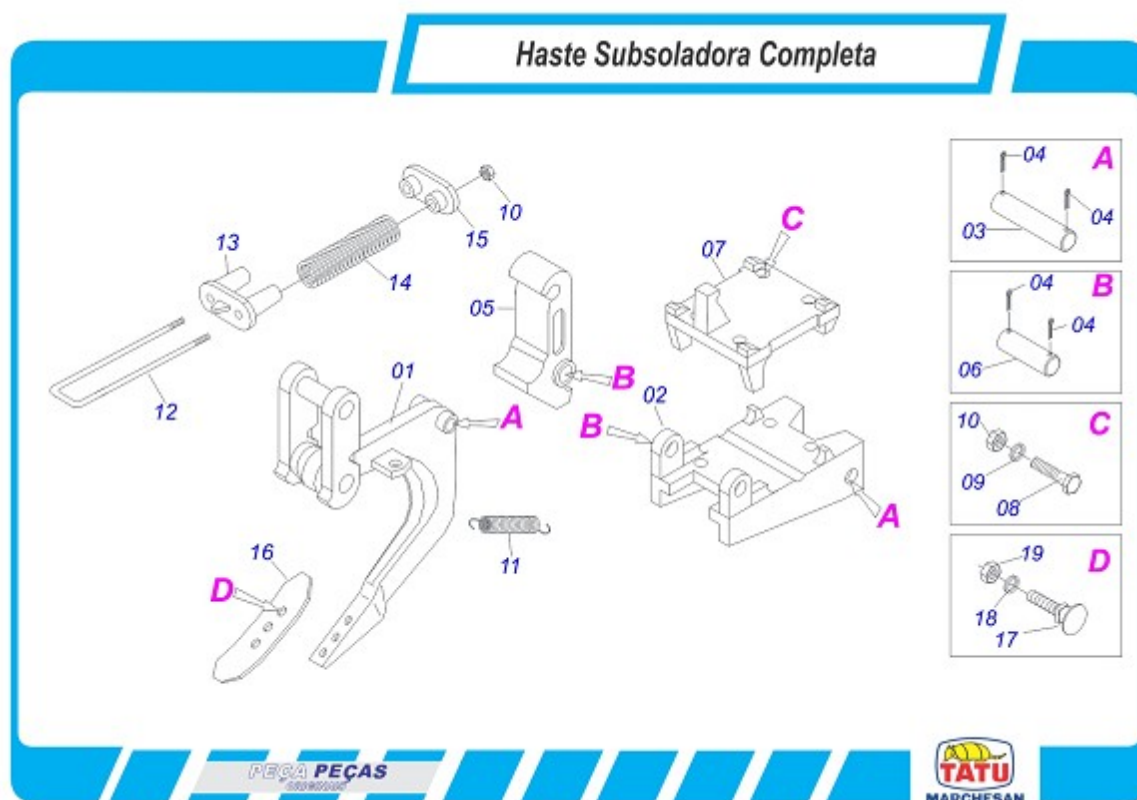

Item	Code	Description	
00	0501049402	SHANKS SYSTEM ASSY	
01	0511061712	ARM SUBSOILER	01
02	0502011863	LOWER BASE FIXER	01
03	0521017725	1" X 7.4" COUPLING SHAFT	02
04	0503010523	1/4" X 2" COTTERPIN	04
05	0502011864	AST/MATIC 450 RESET	01
06	0521017724	1" X 6.2" COUPLING SHAFT	01
07	0502011861	FIXER BASE UPPER	01
08	0503012729	3/4" X 6-3/4" BOLT	04
09	0503010023	3/4" SPRING WASHER	04
10	0503010014	3/4" NUT	08
11	0503031574	6.9" X 0.8" X 0.1" EXTENSION SPRING	01
12	0521015426	3/4" X 18" FASTENER	01
13	0502011860	SPRING LOWER SUPPORT	01
14	0503031575	2.5" X 12" X 0.5" COMPRESSION SPRING	02
15	0502011866	SPRING UPPER SUPPORT	01
16	0624010005	POINT SUBSOILER	01
17	0503012956	1/2" X 1-1/2" BOLT	03
18	0503010019	1/2" SPRING WASHER	03
19	0503010020	1/2" NUT	03

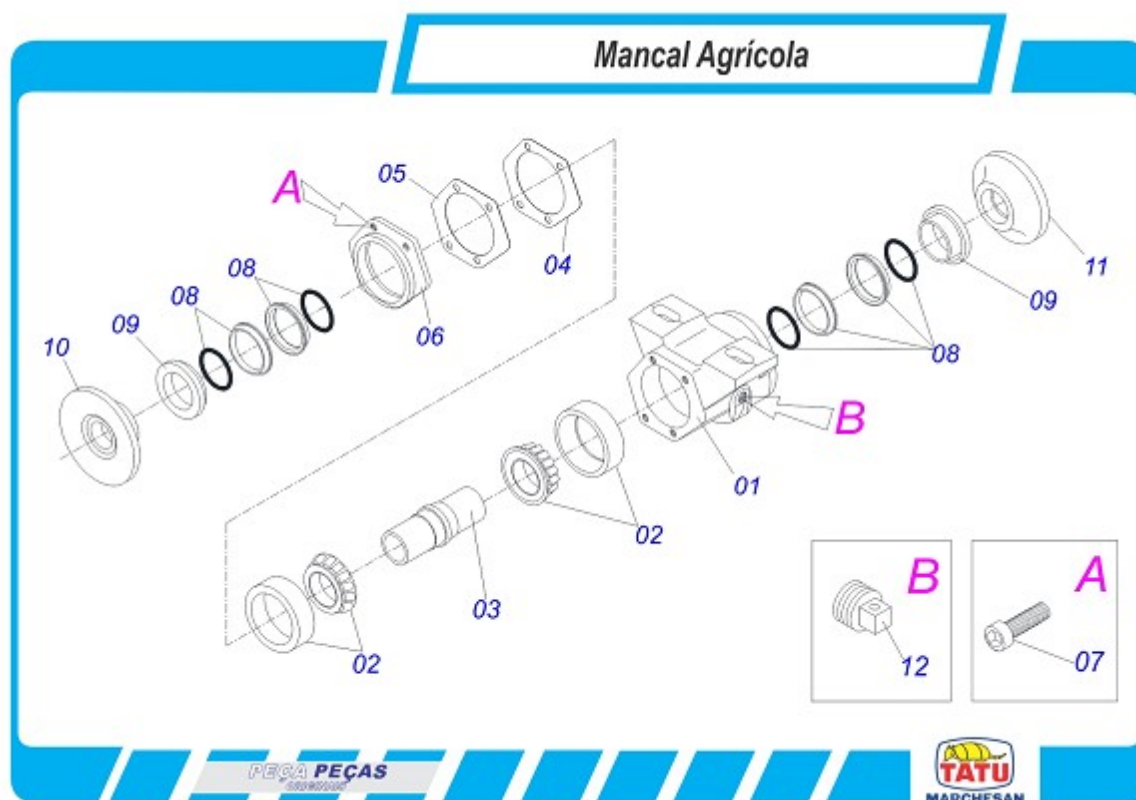

Item	Code	Description	
00	0501042180	7.5" X 1-1/4" OIL BATH BEARING	01
01	0502010539	HOUSING DM	01
02	0503010111	30210 ROLLER BEARING	02
03	0502040218	AXLE	01
04	0503030013	4.4" X 3.5" X 0.004" JOINT	02
05	0503030684	4.4" X 3.5" X 0.004" JOINT	01
06	0502020424	HOUSING CAP DM	01
07	0503010134	3/8" X 1" BOLT	04
08	0503030026	SEAL # LP JB-253	02
09	0502010541	SEAL RETAINER	02
10	0502010070	OUTER FLANGE	01
11	0502010071	INNER FLANGE	01
12	0503010856	3/8" OIL PLUG	01

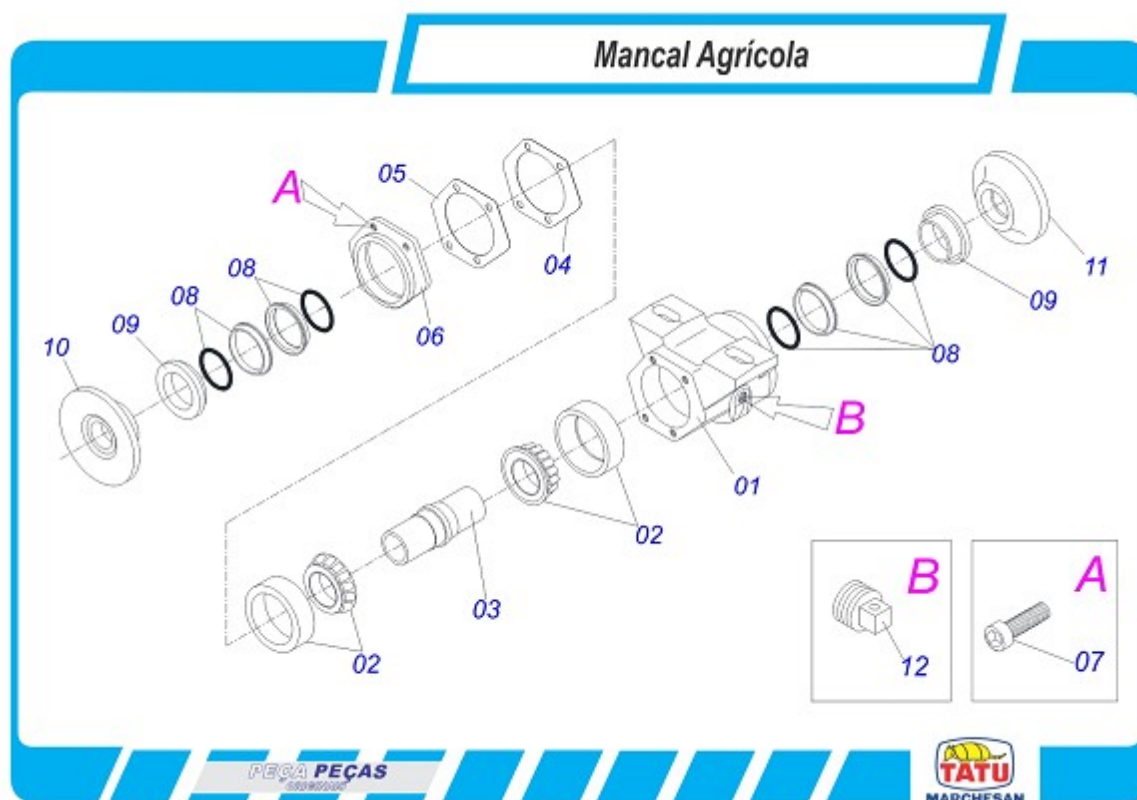

Item	Code	Description	
00	0501046922	7.5" X 1-1/4" OIL BATH BEARING	01
01	0502010540	HOUSING DM	01
02	0503010111	30210 ROLLER BEARING	02
03	0502040218	AXLE	01
04	0503030013	4.4" X 3.5" X 0.004" JOINT	02
05	0503030684	4.4" X 3.5" X 0.004" JOINT	01
06	0502020424	HOUSING CAP DM	01
07	0503010134	3/8" X 1" BOLT	04
08	0503030026	SEAL # LP JB-253	02
09	0502010541	SEAL RETAINER	02
10	0502010070	OUTER FLANGE	01
11	0502010071	INNER FLANGE	01
12	0503010856	3/8" OIL PLUG	01

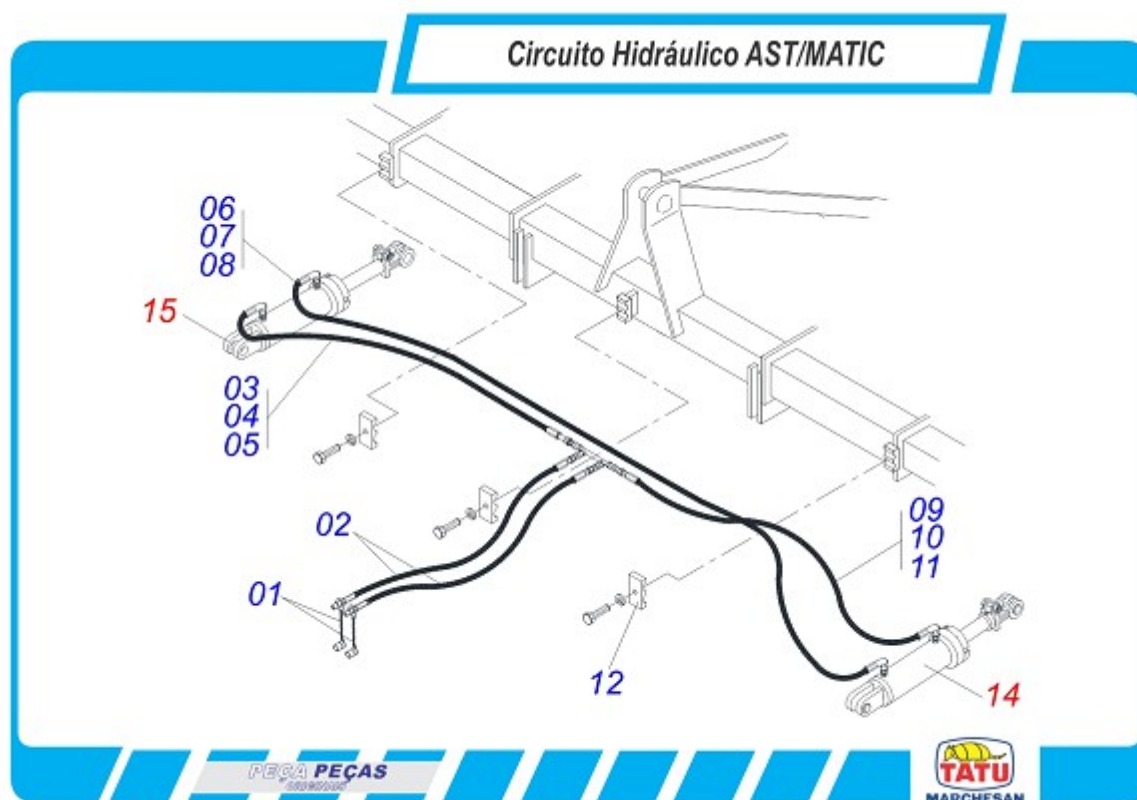

Item	Code	Description	05	07	09	11	13
01	0501053834	QUICK CONECTION (MALE) 1/2NPT	02	02	02	02	02
02	0501080384	3/8" X 118" TR-TM HOSE ASSY	01	01	01	01	01
03	0501080302	3/8" X 51" TR-TC HOSE ASSY	01	00	00	00	00
04	0501080402	3/8" X 67" TR-TC HOSE ASSY	00	01	00	01	00
05	0501080419	3/8" X 83" TR-TC HOSE ASSY	00	00	01	00	00
06	0501080370	3/8" X 95" TC-TC HOSE ASSY	01	00	00	00	00
07	0501080479	3/8" X 120" TC-TC HOSE ASSY	00	01	00	01	00
08	0501080578	3/8" X 157" TC-TC HOSE ASSY	00	00	01	00	01
09	0501080386	3/8" X 41" TR-TC HOSE ASSY	01	00	00	00	00
10	0501080025	3/8" X 55" TR-TC HOSE ASSY	00	01	00	01	00
11	0501080431	3/8" X 75" TR-TC HOSE ASSY	00	00	01	00	00
12	0502010477	UPPER CLAMP BODY	03	03	03	03	03
13	0501068088	OIL TUBE	01	01	01	01	01
14	0511043790	44,45 X 85,7 X 515 X 203 HYDRAULIC CYLINDER	01	01	01	01	01
15	0511043786	HYDRAULIC CYLINDER 203 BP	01	01	01	01	01

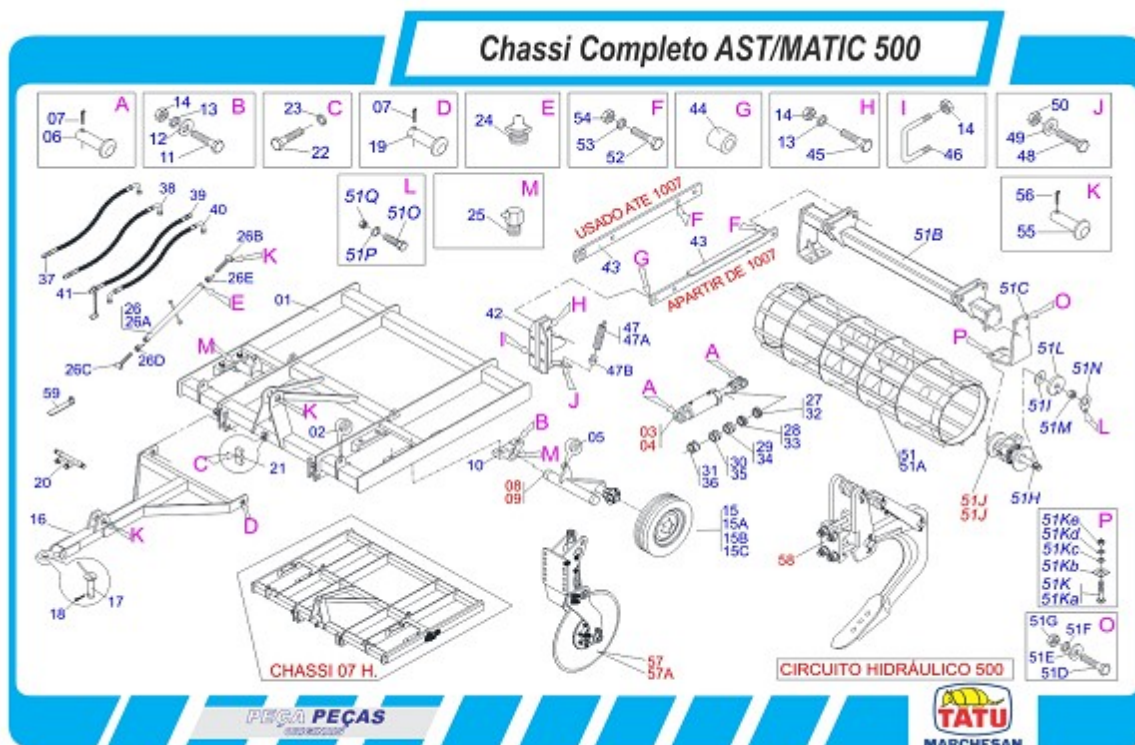

Item	Code	Description	05 HASTES
01	0511065149	FRAME	01
02	0511019921	1.3" X 0.1" X 1" SLEEVE	02
03	0511043611	HYDRAULIC CYLINDER	01
04	0511043610	HYDRAULIC CYLINDER	01
05	0511019920	1.5" X 0.1" X 1" SLEEVE	02
06	0521012538	1.2" X 3.5" COUPLING SHAFT	04
07	0503010523	1/4" X 2" COTTERPIN	06
08	0501054990	FURROW WHEEL RIGHT SUPPORT	01
09	0501054991	LH SUPPORT STUB SHAFT & HUB	01
10	0501110563	LH PIVOT BEARING	04
10.	0501110568	WHEEL PIVOT BEARING	04
11	0503010901	3/4" X 3-1/2" BOLT	08
12	0501010322	FLAT WASHER	08
13	0503011442	3/4" SPRING WASHER	08
14	0503010014	3/4" NUT	08
15	0503060091	29.5"X0.63"-10L WHEEL AND TIRE ASSY	02
15A	0503010893	0.22" X 0.63" WHEEL	02
15B	0503010033	7.50 X 16 INNER TIRE	02
15C	0503010120	CANVAS TIRE	02
16	0501067791	DRAWBAR	01
17	0501066637	DRAWBOLT	01
18	0503010073	3/8" X 3-1/2" COTTERPIN	06
19	0521010596	1.1" X 4.7" COUPLING SHAFT	02
20	0511066476	OIL TUBE	01
21	0502010477	UPPER CLAMP BODY	03
22	0503010751	3/8" X 1.1/4" HEX BOLT G.5	03
23	0503010025	3/8" SPRING WHASHER	03
24	0503010002	GREASE FITTING	04
25	0503010004	GREASE FITTING	04
26	0501047356	ESTABILIZER ASSY	01
26A	0501068095	850 ADJUSTMENT NUT	01
26B	0501068096	RIGTH TURNBUCLE	01
26C	0501068097	LEFT TURNBUCLE	01



AST/MATIC 500

0909091341

Item	Code	Description	05 HASTES
26D	0541018673	LOCKNUT WITH LEFT R 2-1/2"	01
26E	0541018672	LOCKNUT WITH RIGHT HANDLER R 1-1/2"	01
27	0501047887	1.57" ROD STOP	01
28	0501047888	1.77" ROD STOP	01
29	0501047889	1.96" ROD STOP	01
30	0511042292	2.16"ROD STOP	01
31	0501047899	2.4" ROD STOP	01
32	0501052865	1.57" ROD STOP	01
33	0501055024	45 ROD STOP	01
34	0501052866	1.96" ROD STOP	01
35	0501055025	55 ROD STOP	01
36	0501055026	61 ROD STOP	01
37	0501080986	1/2" X 55.12" TR-TC HOSE ASSY	01
38	0501081028	1/2" X 1700 TR-TC HOSE ASSY	01
39	0501081030	1/2" X 3000 TR-TM OFS HOSE	02
40	0501081029	1/2" X 3000 TC-TC HOSE ASSY	01
41	0501053834	QUICK CONECTION (MALE) 1/2NPT	02
42	0501068437	BREAK ROLLER SUPPORT FIXATION	02
43	0511069306	FIXER ROLLER ARM	02
44	0511018178	1.2" X 0.8" X 0.7" BUSHING	02
45	0501010827	3/4" X 2-3/4" BOLT	02
46	0521014574	3/4" X 6.3" X 5.1" FASTENE	04
47	0501053355	HITCH TRACTION SPRING	02
47A	0503030806	2.3" X 8" X 0.3" TRACTION SPRING	02
47B	0502011060	SUPPORT SPRING	02
48	0503011264	1/2" X 2-1/2" BOLT	02
49	0511017302	FLAT WASHER	02
50	0503010060	1/2" NUT	02
51	0501054969	BREAK ROLLER ARM	01
51A	0511065139	2066 BREAK ROLLER	01
51B	0511065140	2080 BREAK ROLLER SUPPORT	01
51C	0511069433		01
51D	0501010100	5/8" X 2" BOLT	04
51E	0501012140	FLAT WASHER	04
51F	0503011445	5/8" SPRING WASHER	04
51G	0503010013	5/8" NUT	04
51H	0511017878	1.1/4 X 2105 AXLE	01
51I	0531018575	WASHER CONCAVE	02
51J	0501042180	7.5" X 1-1/4" OIL BATH BEARING	02
51K	0501048788	5/8" X 2-1/2" BOLT ASSY	04
51Ka	0501014177	5/8" X 2-1/2" BOLT	01
51Kb	0501010947	5/8" SQUARE WASHER	01
51Kc	0501012140	FLAT WASHER	01
51Kd	0503011445	5/8" SPRING WASHER	01
51Ke	0503010013	5/8" NUT	01
51L	0502010835	1-1/4" EXTERNAL AXLE WASHER	02
51M	0501010087	1.1/4" UNC NUT	02
51N	0501010455	1-1/4" 2.04" NUT LOCK	02
51O	0501010161	1/2" X 1-1/4" BOLT	02
51P	0503010019	1/2" SPRING WASHER	05
51Q	0503010060	1/2" NUT	02
52	0501010276	1" X 3" BOLT	04
53	0503010012	1" SPRING WASHER	04
54	0501010059	1" NUT	04
55	0521010579	0.9" X 4.5" COUPLING SHAFT	02
56	0503010571	1/4" X 1.1/2" COTTERPIN	02
57	0521040619	REAR BLADE DISC ASSY	05
57A	0521040616	FRONT BLADE DISC ASSY	07
58	0511045923	SHANKS SYSTEM ASSY	05
59	0503033367	"1" WRENCH	01

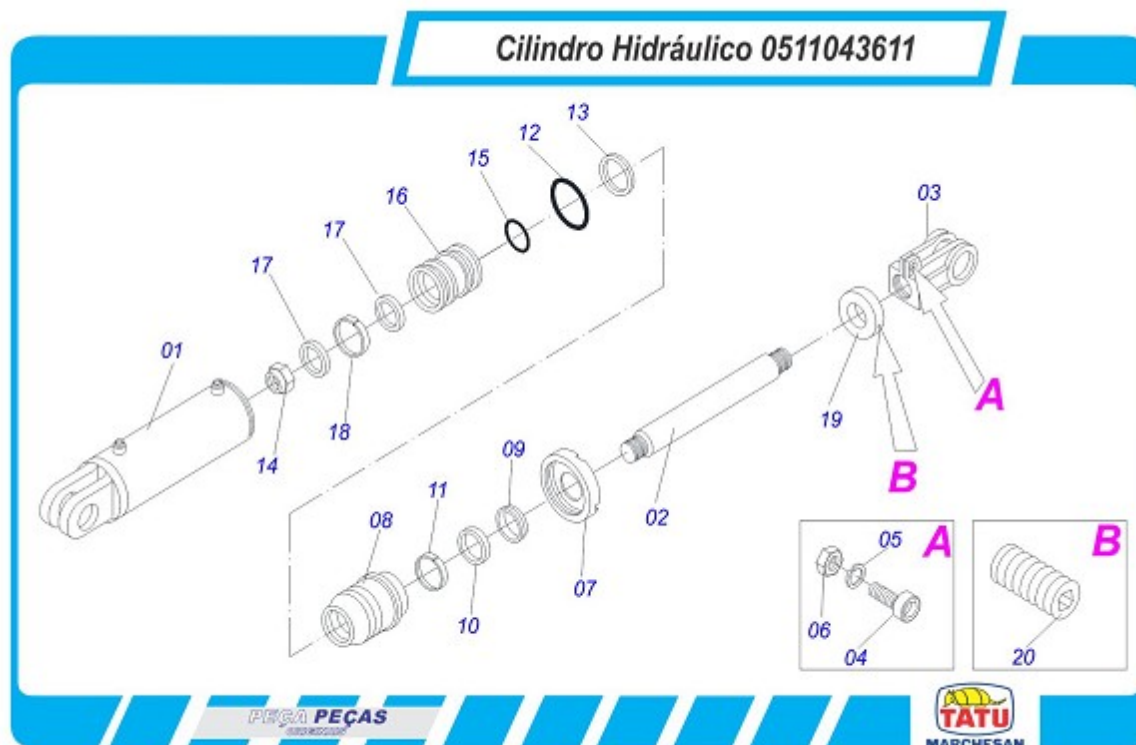

Item	Code	Description	
00	0511043611	HYDRAULIC CYLINDER	01
01	0511066480	85,72 X 430 CYLINDER CASE	01
02	0521016677	1.75" X 17.5" TURNBUCLE	01
03	0502040747	FORK	01
04	0503011094	3/8" X 2" BOLT C C S I 12.9	01
05	0503010025	3/8" SPRING WHASHER	01
06	0503010026	3/8" NUT	01
07	0502010993	DETACHABLE COVER	01
08	0502010781	RING SUPPORT	01
09	0503010761	D-1750 SCRAPER RING	01
10	0503010990	GASKET	01
11	0503010949	W2-2000-500 PK RING G.E	01
12	0503010976	2-336 N 3006-9B O'RING	01
13	0503011060	8-336 BACK-UP RING	01
14	0503010063	1" SELF-ALIGNING NUT	01
15	0503010042	2-214 N 3006-9B O'RING	01
16	0502011847	1.7" X 3.4" PISTON	01
17	0503012509	GASKET	02
18	0503010948	W4-3346-590 PK RING G.E	01
19	0511018115	1.8" X 0.1" 0.7" BUSHING	01
20	0503011148	3/8" X 1/2" BOLT	01



Item	Code	Description	
00	0511043610	HYDRAULIC CYLINDER	01
01	0511066479	101,60 X 444 CYLINDER CASE	01
02	0531018706	2.1" X 17" EXTENDING BODY	01
03	0502040747	FORK	01
04	0503011094	3/8" X 2" BOLT C C S I 12.9	01
05	0503010025	3/8" SPRING WHASHER	01
06	0503010026	3/8" NUT	01
07	0502011182	4" DETACHABLE COVER	01
08	0502011250	2.1 X 4" RING SUPPORT	01
09	0503010319	D-2125 SCRAPER	01
10	0503010314	GASKET	01
11	0503010973	W2-2500-500 PK RING G.E	01
12	0503011061	8-342 BACK-UP RING	01
13	0503010338	2-342 N 3006-9B O'RING	01
14	0503010345	2-218 N 3006-9B O'RING	01
15	0502011249	2.1 X 4" PISTON	01
16	0503010043	PACKING 3750-3250	01
17	0503012725	GASKET	01
18	0503012726	RUBBER RING	01
19	0503010994	W2-4000-500 PK RING G.E	01
20	0503010817	1.1/4" UNF SELF ADJUSTING NUT	01

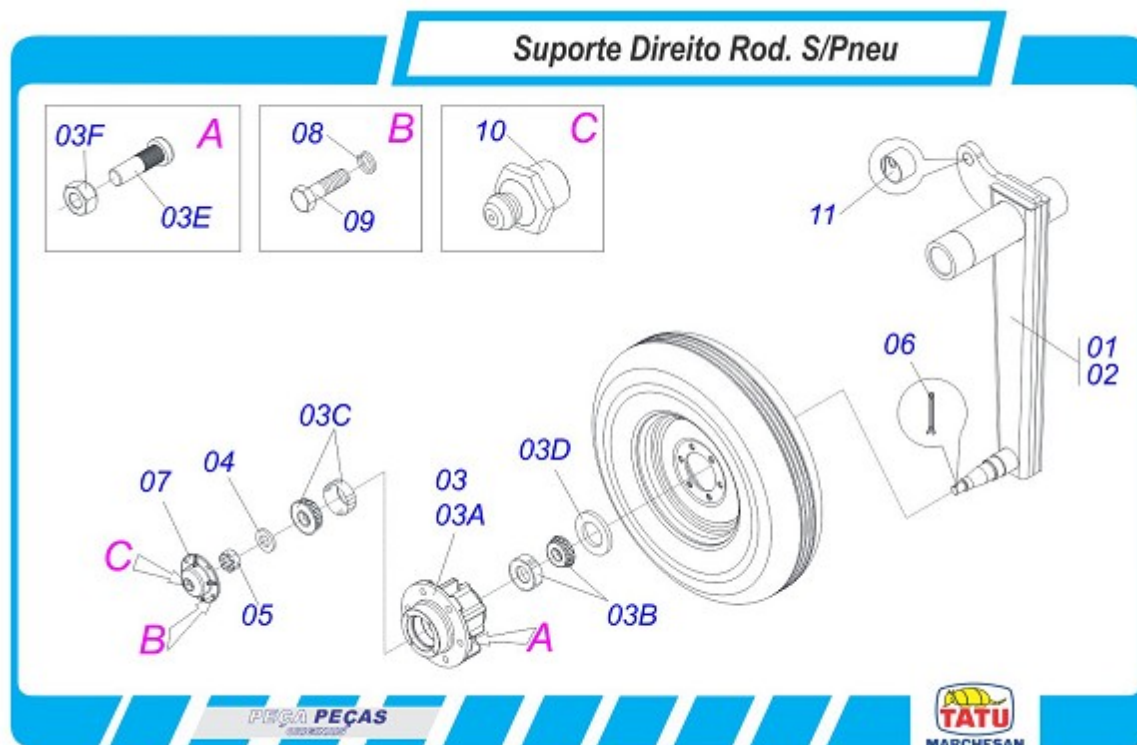

Item	Code	Description	QT
01	0501054990	FURROW WHEEL RIGHT SUPPORT	QT
02	0511065157	RIGHT CARRYING-WHEELS	01
03	0501051142	CARRYING WHEEL HUB	01
03A	0502011121	CARRYING WHEEL HUB	01
03B	0503010006	32210 ROLLER BEARING	01
03C	0503010037	30207 ROLLER BEARING	01
03D	0503012928	SEAL 5985-GB	01
03E	0501010127	9/16" X 1-7/8" LUG BOLT	06
03F	0503010035	9/16" CONIC NUT	06
04	0501016545	FLAT WASHER	01
05	0503030009	1" X 0.9" CASTLE NUT	01
06	0503010018	5/32" X 1-1/2" COTTERPIN	01
07	0502020591	COVER	01
08	0503010179	5/16" SPRING WASHER	04
09	0503010358	5/16" X 7/8" BOLT	04
10	0503010002	GREASE FITTING	01
11	0511019920	1.5" X 0.1" X 1" SLEEVE	01

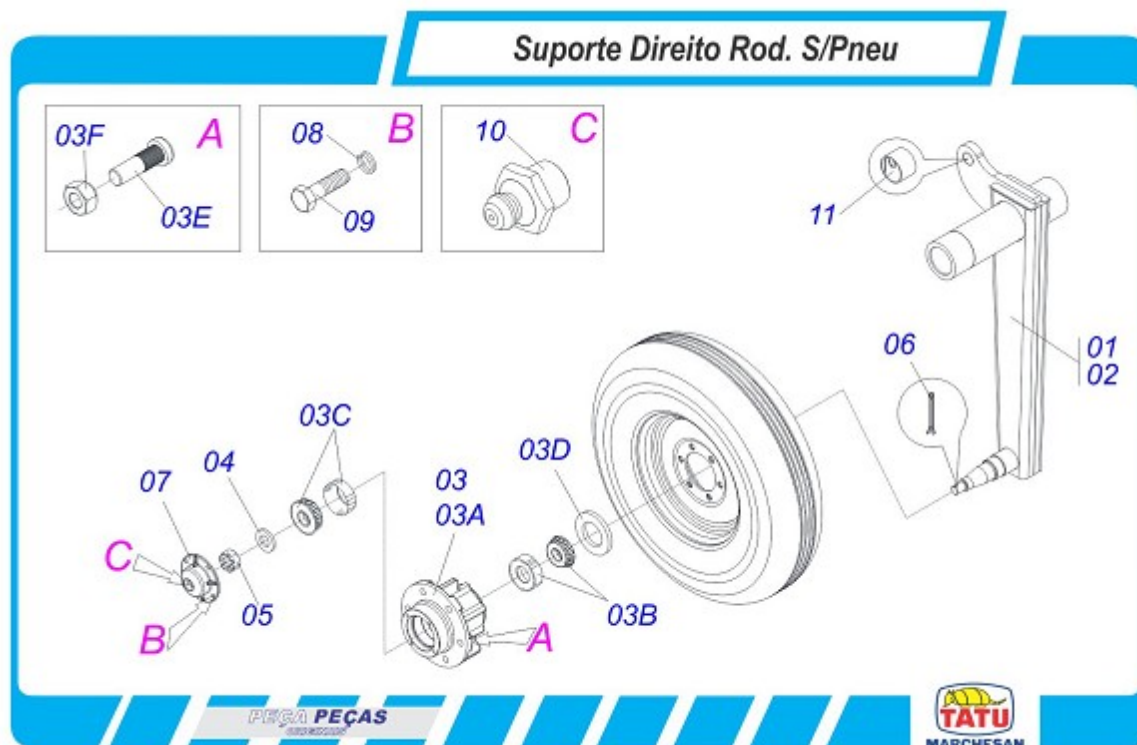

Item	Code	Description	05/07HASTES
01	0501054991	LH SUPPORT STUB SHAFT & HUB	01
02	0511065158	LEFT CARRYING-WHEELS	01
03	0501051142	CARRYING WHEEL HUB	01
03A	0502011121	CARRYING WHEEL HUB	01
03B	0503010006	32210 ROLLER BEARING	01
03C	0503010037	30207 ROLLER BEARING	01
03D	0503012928	SEAL 5985-GB	01
03E	0501010127	9/16" X 1-7/8" LUG BOLT	06
03F	0503010035	9/16" CONIC NUT	06
04	0501016545	FLAT WASHER	01
05	0503030009	1" X 0.9" CASTLE NUT	01
06	0503010018	5/32" X 1-1/2" COTTERPIN	01
07	0502020591	COVER	01
08	0503010179	5/16" SPRING WASHER	04
09	0503010358	5/16" X 7/8" BOLT	04
10	0503010002	GREASE FITTING	01
11	0511019920	1.5" X 0.1" X 1" SLEEVE	01

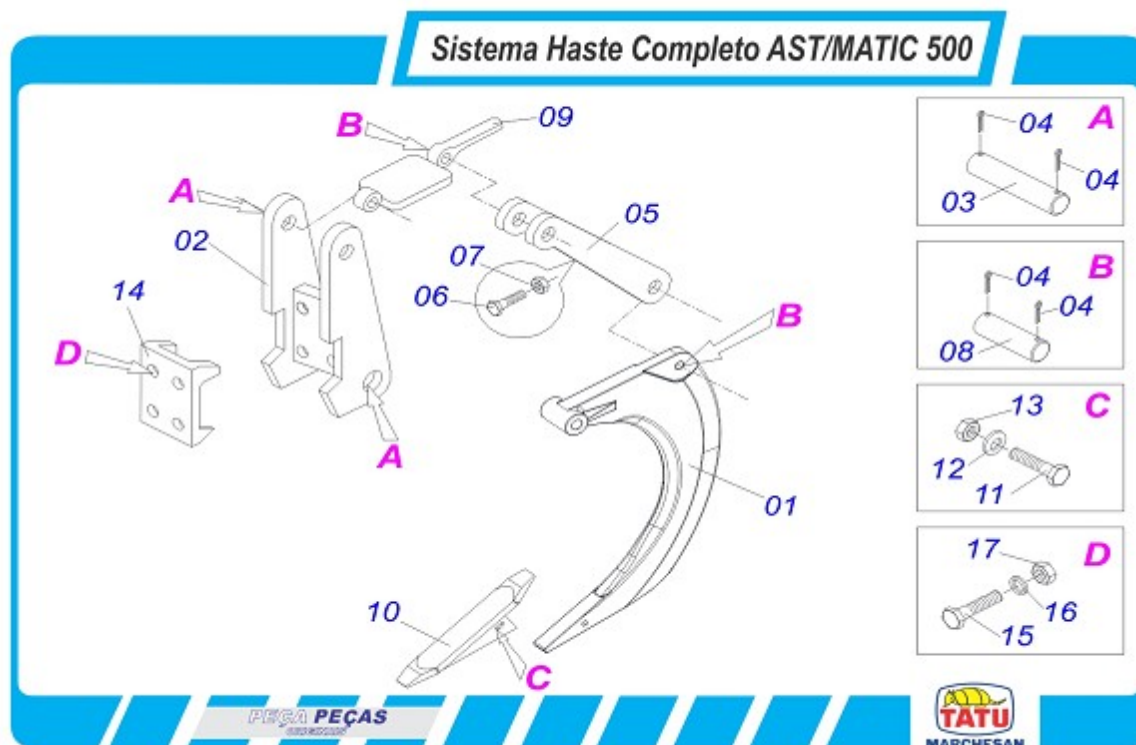

Item	Code	Description	05/07HASTES
01	0511045923	SHANKS SYSTEM ASSY	01
01A	0502012451		01
02	0502011551	REAR FIXER	01
03	0521013024	28,50 X 184 AXLE	02
04	0503010571	1/4" X 1.1/2" COTTERPIN	08
05	0502011164	SUPPORT SPRING	01
06	0503011135	7/16" X 1-1/2" BOLT	01
07	0503010244	7/16" NUT	01
08	0511015689	1.1" X 3.5" COUPLING SHAFT	02
09	0521011631	AUTOMATIC RESET	01
10	0511068435	POINT SUBSOILER	01
11	0503010850	7/16" X 3" BOLT	01
12	0501012803	FLAT WASHER	01
13	0503010244	7/16" NUT	01
14	0502011552	FRONT FIXER	01
15	0511019527	1" X 8" BOLT	04
16	0503011438	1" SPRING WASHER	04
17	0503010063	1" SELF-ALIGNING NUT	04

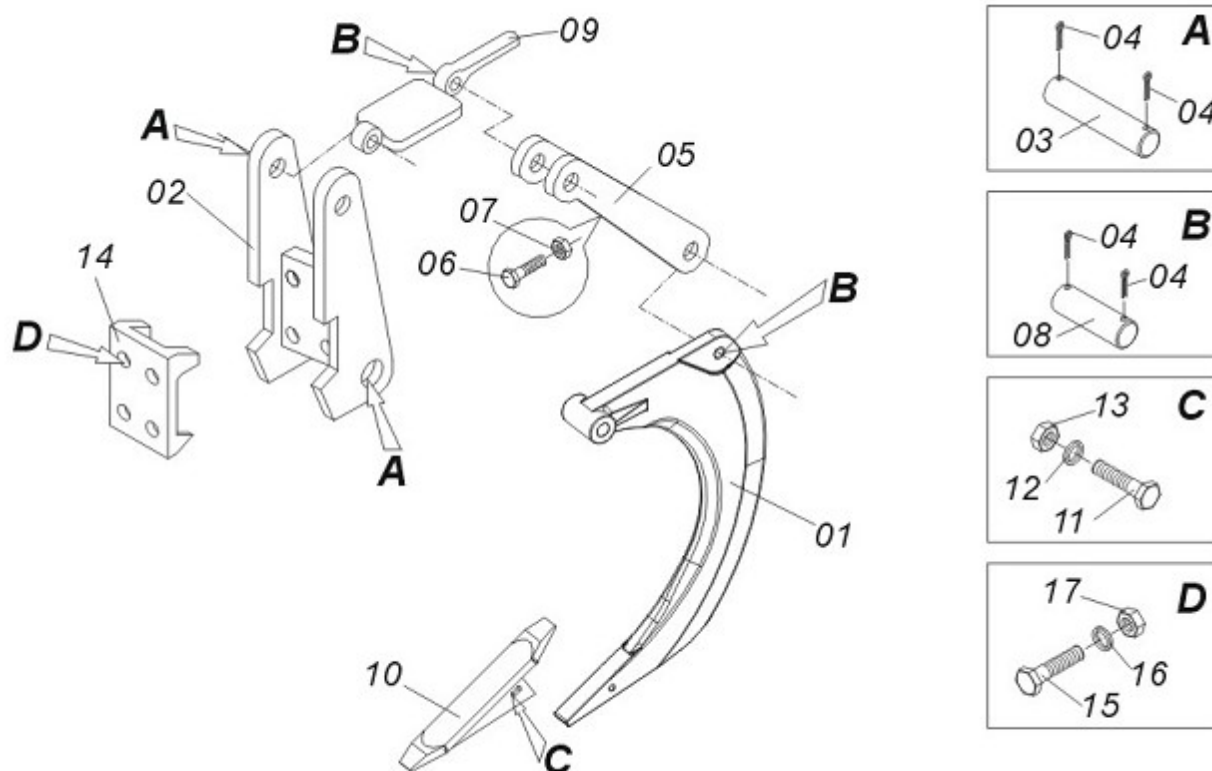

Item	Code	Description	
00	0511042270	SHANKS SYSTEM ASSY	
01	0502012451		01
02	0502011551	REAR FIXER	01
03	0521013024	28,50 X 184 AXLE	02
04	0503010523	1/4" X 2" COTTERPIN	04
05	0502011164	SUPPORT SPRING	01
06	0503011173	7/16" X 2" BOLT	01
07	0503010244	7/16" NUT	01
08	0511015689	1.1" X 3.5" COUPLING SHAFT	02
09	0521011631	AUTOMATIC RESET	01
10	0511068437	SUBSOILER TIP CUERPO	01
11	0503010741	1/2" X 2-3/4" BOLT	02
12	0503011440	1/2" SPRING WASHER	02
13	0503010060	1/2" NUT	02
14	0502011552	FRONT FIXER	01
15	0511019527	1" X 8" BOLT	04
16	0503011438	1" SPRING WASHER	04
17	0503010063	1" SELF-ALIGNING NUT	04

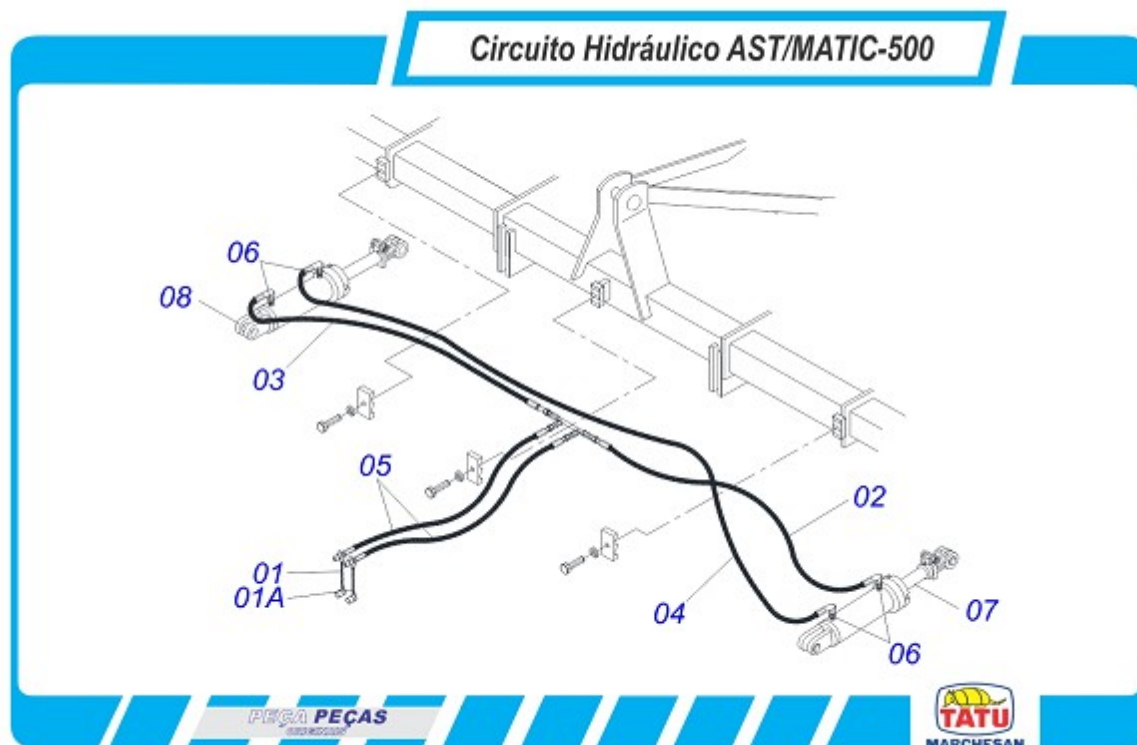

Item	Code	Description	
01	0501057520		01
01.	0501056057		01
01A	0501053834	QUICK CONECTION (MALE) 1/2NPT	02 02
02	0501080984	1/2" X 39.37" TR-TC HOSE ASSY	01
02.	0501080986	1/2" X 55.12" TR-TC HOSE ASSY	01
03	0501081131		01
03.	0501081028	1/2" X 1700 TR-TC HOSE ASSY	01
04	0501081226	1/2" X 2350 TC-TC HOSE ASSY	01
04.	0501081029	1/2" X 3000 TC-TC HOSE ASSY	01
05	0501081030	1/2" X 3000 TR-TM OFS HOSE	02 02
06	0503030923	3/4" UNF X 13/16UN OFS X 40 NIPPLE	04 04
07	0511043610	HYDRAULIC CYLINDER	01 01
08	0511043611	HYDRAULIC CYLINDER	01 01

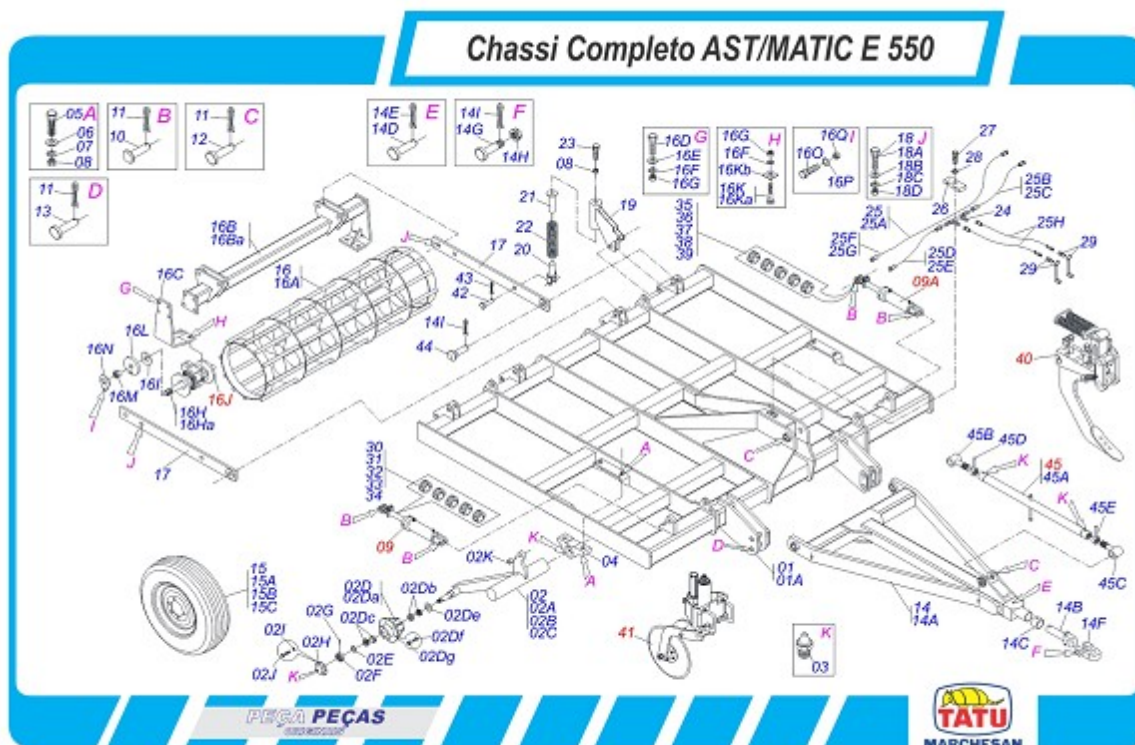

Item	Code	Description	05	07
00	0909090360	ASTMATIC 550		
01	0511063808	AST/MATIC E 550 FRAME	01	00
01A	0511063809	AST/MATIC E 550 7H FRAME	00	01
02	0501054059	RIGHT SUPPORT STUB SHAFT & HUB ASSY	01	01
02A	0501054060	LEFT SUPPORT STUB SHAFT & HUB ASSY	01	01
02B	0511063803	RIGHT GANG CARRYING-WHEEL SUPPORT	01	01
02C	0511063804	LEFT GANG CARRYING-WHEEL SUPPORT	01	01
02D	0501051142	CARRYING WHEEL HUB	02	02
02Da	0502011121	CARRYING WHEEL HUB	02	02
02Db	0503010006	32210 ROLLER BEARING	02	02
02Dc	0503010037	30207 ROLLER BEARING	02	02
02De	0503012928	SEAL 5985-GB	02	02
02Df	0501010127	9/16" X 1-7/8" LUG BOLT	12	12
02Dg	0503010035	9/16" CONIC NUT	12	12
02E	0501016545	FLAT WASHER	02	02
02F	0503030009	1" X 0.9" CASTLE NUT	02	02
02G	0503010018	5/32" X 1-1/2" COTTERPIN	02	02
02H	0502020591	COVER	02	02
02I	0503010179	5/16" SPRING WASHER	08	08
02J	0503010178	5/16" X 7/8" BOLT	08	08
02K	0511019920	1.5" X 0.1" X 1" SLEEVE	02	02
03	0503010002	GREASE FITTING	06	06
04	0502012273	PIVOT BEARING	04	04
05	0503010901	3/4" X 3-1/2" BOLT	08	08
06	0501010322	FLAT WASHER	08	08
07	0503010023	3/4" SPRING WASHER	08	08
08	0503010014	3/4" NUT	12	12
09	0501049308	1.7" X 3.4" X 22" X 10" HYDRAULIC CYLINDER	01	01
09A	0511041525	2.0" X 4" X 22" X 10" HYDRAULIC CYLINDER	01	01
10	0521012538	1.2" X 3.5" COUPLING SHAFT	04	04
11	0503010523	1/4" X 2" COTTERPIN	08	08
12	0521013665	UPPER AXLE HITCH	02	02
13	0521013666	LOWER AXLE HITCH	02	02



ASTMATIC 550

0909090360

Item	Code	Description	05	07
14	0511041101	DRAWBAR ASSY	01	01
14A	0511063767	DRAWBAR	01	01
14B	0502040223	DRAWBOLT	01	01
14C	0502040327	LOCK SLEEVE	01	01
14D	0511014902	0.9" X 3.7" COUPLING SHAFT	01	01
14E	0503010571	1/4" X 1.1/2" COTTERPIN	01	01
14F	0502040732	CLEVIS	01	01
14G	0521012545	1.5" X 7.2" COUPLING SHAFT	01	01
14H	0501011301	1.1/2" CASTLE NUT	01	01
14I	0503010010	1/4" X 2.1/2" COTTERPIN	01	01
15	0503060181	WELL AND TIRE ASSY	02	02
15A	0503010858	TIRE 11L-15	02	02
15B	0503011468	WEEL 10L	02	02
15C	0503010860	11L 15 INNER TIRE	02	02
16	0501054554	SUPPOR WITH BREAK ROLLER	01	01
16.	0501054555	BREAK ROLLER	02	02
16A	0511064541	BREAK ROLLER	01	01
16A.	0511064542	BREAK ROLLER	02	02
16B	0511064315	BREAK ROLLER SUPPORT	02	
16Ba	0511064316	BREAK ROLLER SUPPORT	02	
16C	0511064543	BREAK ROLLER BRACKET	02	02
16D	0501010100	5/8" X 2" BOLT	08	08
16E	0501012140	FLAT WASHER	08	08
16F	0503010027	5/8" SPRING WASHER	16	16
16G	0503010013	5/8" NUT	16	16
16H	0531018573	1-1/4" X 51.57" AXLE	04	04
16Ha	0531018574	1-1/4" X 72" AXLE	04	04
16I	0531018575	WASHER CONCAVE	04	04
16J	0501042180	7.5" X 1-1/4" OIL BATH BEARING	04	04
16K	0501048788	5/8" X 2-1/2" BOLT ASSY	08	08
16Ka	0501014177	5/8" X 2-1/2" BOLT	01	01
16Kb	0501010947	5/8" SQUARE WASHER	01	01
16L	0502010835	1-1/4" EXTERNAL AXLE WASHER	08	08
16M	0501010087	1.1/4" UNC NUT	04	04
16N	0501010455	1-1/4" 2.04" NUT LOCK	04	04
16O	0501010161	1/2" X 1-1/4" BOLT	04	04
16P	0503010019	1/2" SPRING WASHER	04	04
16Q	0503010060	1/2" NUT	04	04
17	0511063807	BREAK ROLLER ARM	04	04
18	0501042312	1" X 3-1/2" ASSY BOLT	08	08
18A	0501010171	1" X 3-1/2" BOLT	08	08
18B	0501011518	FLAT WASHER	08	08
18C	0503010012	1" SPRING WASHER	08	08
18D	0501010059	1" NUT	08	08
19	0511064544	SUPPORT ARTICULACION BREAK ROLLER	04	04
20	0511064546	SPRING LOWER SUPPORT	04	04
21	0511064547	SPRING UPPER SUPPORT	04	04
22	0503031560	2.7" X 13.8" X 0.5" SPRING	04	04
23	0503013135	3/4" X 4" BOLT	04	04
24	0501068088	OIL TUBE	01	01
25	0501054054	HOSE ASSY	01	01
25A	0501054055	HOSE ASSY	01	01
25B	0501080321	3/8" X 47" TR-TR HOSE ASSY	01	00
25C	0501080047	3/8" X 67" TR-TR HOSE ASSY	00	01
25D	0501080488	3/8" X 51" TR-TR HOSE ASSY	01	00
25E	0501080128	3/8" X 71" TR-TR HOSE ASSY	00	01
25F	0501080452	3/8" X 98" TR-TR HOSE ASSY	01	00
25G	0501080372	3/8" X 136" TR-TR HOSE ASSY	00	01
25H	0501080510	3/8" X 137" TR-TR HOSE ASSY	02	02
26	0502011472	UPPER CLAMP BODY	01	01
27	0503011102	7/16" X 1-1/4" BOLT	01	01
28	0503010180	7/16" SPRING WASHER	01	01



ASTMATIC 550

0909090360

Item	Code	Description	05	07
29	0501053834	QUICK CONECTION (MALE) 1/2NPT	02	02
30	0501047884	0.98" ROD STOP	01	01
31	0501047885	1.18" ROD STOP	01	01
32	0501047886	1.38" ROD STOP	01	01
33	0501047887	1.57" ROD STOP	01	01
34	0501047889	1.96" ROD STOP	01	01
35	0501052862	0.98" ROD STOP	01	01
36	0501052863	1.18" ROD STOP	01	01
37	0501052864	1.38" ROD STOP	01	01
38	0501052865	1.57" ROD STOP	01	01
39	0501052866	1.96" ROD STOP	01	01
40	0501049334	SHANKS SYSTEM ASSY	05	07
41	0501054090	BLADE DISC ASSYAST/MATIC E550 S0203	05	05
42	0531016610	3/4" X 2" COUPLING SHAFT	04	04
43	0503010362	1/8" X 1.1/4" COTTERPIN	04	04
44	0531017715	1.2" X 3.2" PIVOT SHAFT	04	04
45	0501054088	ESTABILIZER DRAWBAR ASSY	01	01
45A	0511063786	950 TURNUCLE	01	01
45B	0511063787	1.1/2" X 17" RIGTH JACK	01	01
45C	0511063788	1.1/2" X 17" LEFT JACK	01	01
45D	0501061056	LOOKNUT WITH RIGTH HANDLER	01	01
45E	0501067133	LOOKNUT WITH LEFT HANDLER	01	01

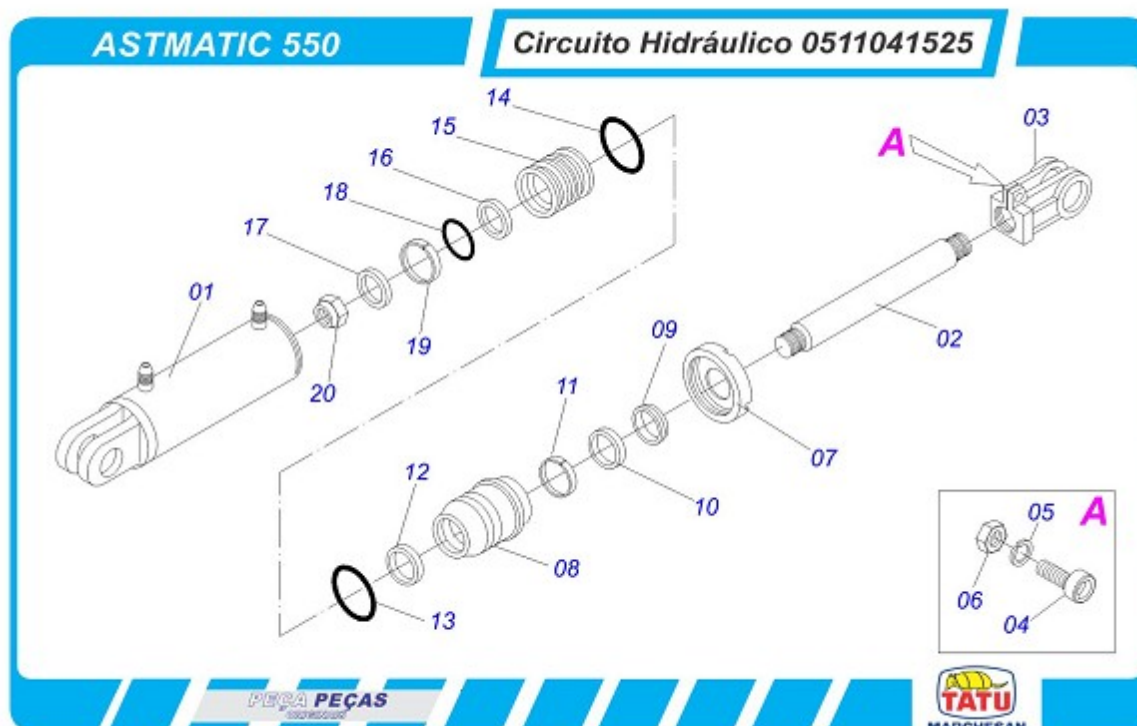

Item	Code	Description	
00	0511041525	2.0" X 4" X 22" X 10" HYDRAULIC CYLINDER	
01	0511061484	4" X 17" CYLINDER CASE	01
02	0531018706	2.1" X 17" EXTENDING BODY	01
03	0502040747	FORK	01
04	0503011094	3/8" X 2" BOLT C C S I 12.9	01
05	0503010025	3/8" SPRING WHASHER	01
06	0503010026	3/8" NUT	01
07	0502011182	4" DETACHABLE COVER	01
08	0502011250	2.1 X 4" RING SUPPORT	01
09	0503010319	D-2125 SCRAPER	01
10	0503010314	GASKET	01
11	0503010973	W2-2500-500 PK RING G.E	01
12	0503011061	8-342 BACK-UP RING	01
13	0503010338	2-342 N 3006-9B O'RING	01
14	0503010345	2-218 N 3006-9B O'RING	01
15	0502011249	2.1 X 4" PISTON	01
16	0503010043	PACKING 3750-3250	01
17	0503012725	GASKET	01
18	0503012726	RUBBER RING	01
19	0503010994	W2-4000-500 PK RING G.E	01
20	0503010817	1.1/4" UNF SELF ADJUSTING NUT	01
21	0501034420	HYDRAULIC CYLINDER REPAIR KIT	

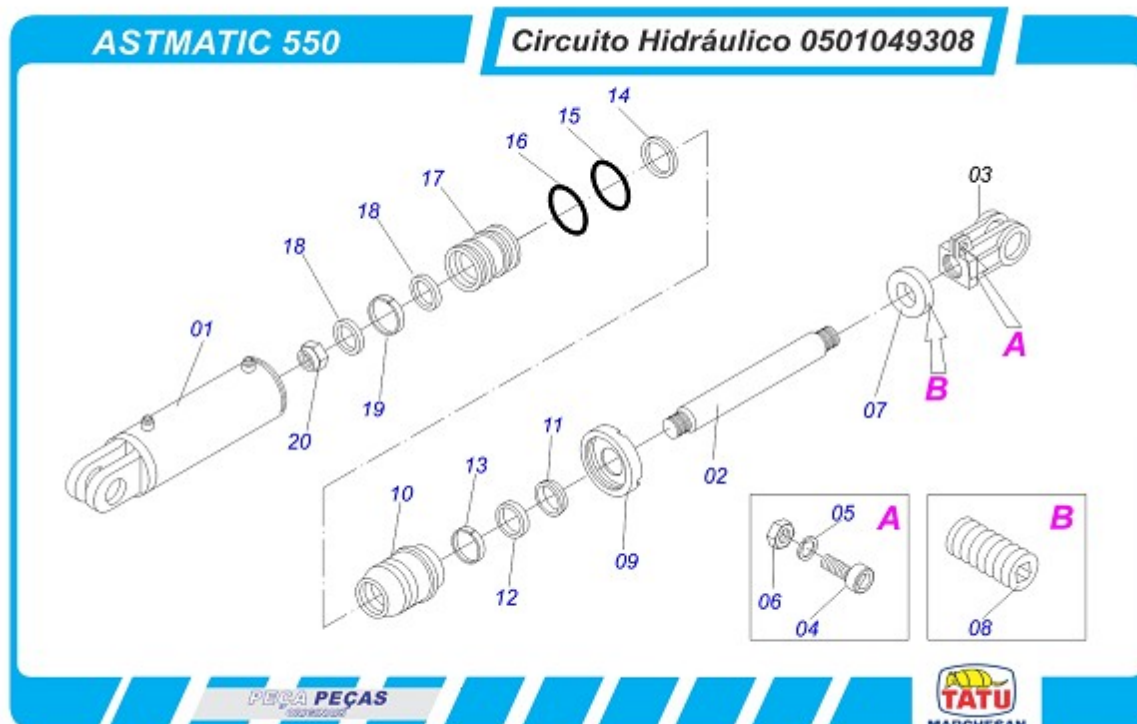

Item	Code	Description	
00	0501049308	1.7" X 3.4 "X 22" X 10" HYDRAULIC CYLINDER	
01	0501069833	3.4" X 17" CYLINDER CASE	01
02	0521016677	1.75" X 17.5" TURNBUCLE	01
03	0502040747	FORK	01
04	0503011094	3/8" X 2" BOLT C C S I 12.9	01
05	0503010025	3/8" SPRING WHASHER	01
06	0503010026	3/8" NUT	01
07	0511018115	1.8" X 0.1" 0.7" BUSHING	01
08	0503011148	3/8" X 1/2" BOLT	01
09	0502010993	DETACHABLE COVER	01
10	0502010781	RING SUPPORT	01
11	0503010761	D-1750 SCRAPER RING	01
12	0503010990	GASKET	01
13	0503010949	W2-2000-500 PK RING G.E	01
14	0503011060	8-336 BACK-UP RING	01
15	0503010976	2-336 N 3006-9B O'RING	01
16	0503010042	2-214 N 3006-9B O'RING	01
17	0502010843	1.8" X 3.4" PISTON	01
18	0503010170	PACKING 3120 2750	02
19	0503010948	W4-3346-590 PK RING G.E	01
20	0503010063	1" SELF-ALIGNING NUT	01
21	0501031796	HYDRAULIC CYLINDER REPAIR KIT	

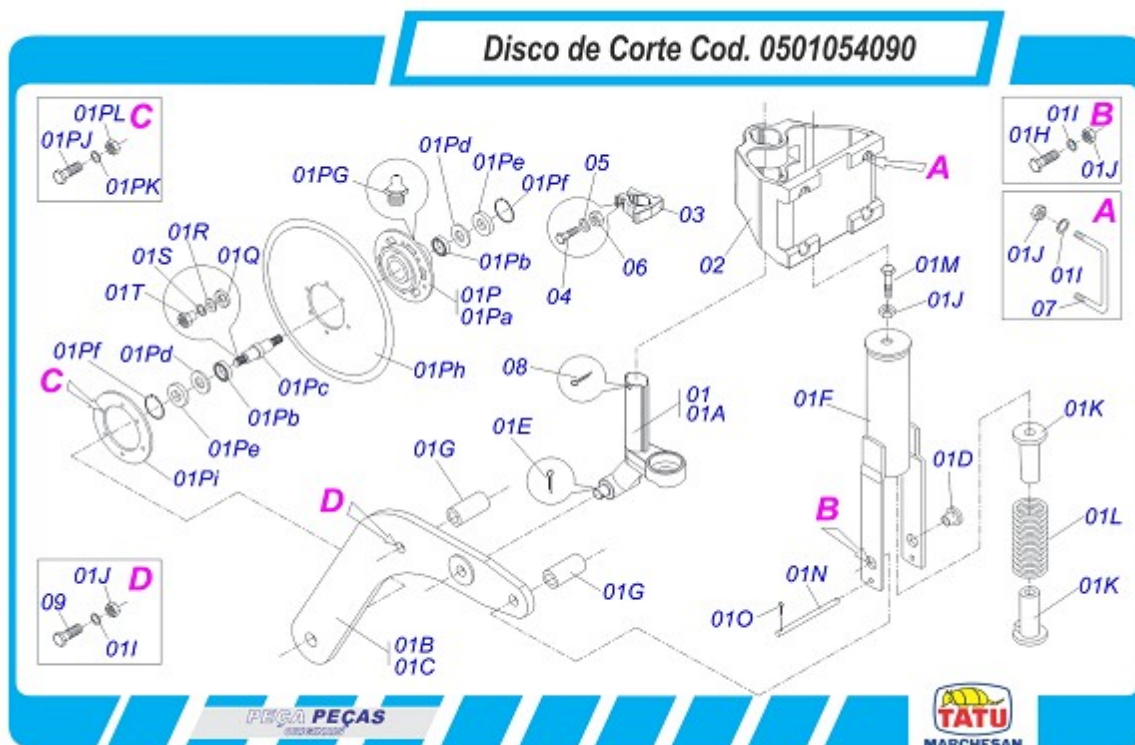

Item	Code	Description	
00	0501054090	BLADE DISC ASSYAST/MATIC E550 S0203	
01	0501054089	BLADE DISC ASSY	01
01A	0502012025	BLADE DISC SUPPORT	01
01B	0511064574	RIGHT ARM OF THE BLADE DISC	01
01C	0511064575	LEFT ARM OF THE BLADE DISC	01
01D	0531018584	BUSHING ARM GUIDE SPRING	02
01E	0503010571	1/4" X 1.1/2" COTTERPIN	02
01F	0511064545	SPRING GUIDE	01
01G	0531018586	0.8" X 1.7" X 3.3" SLEEVE	01
01H	0501010164	3/4" X 7" BOLT	02
01I	0503010023	3/4" SPRING WASHER	06
01J	0503010014	3/4" NUT	07
01K	0511064547	SPRING UPPER SUPPORT	02
01L	0503031560	2.7" X 13.8" X 0.5" SPRING	01
01M	0503013135	3/4" X 4" BOLT	01
01N	0531018585	0.5" X 5.7" COUPLING SHAFT	01
01O	0503010300	5/32" X 1" COTTERPIN	02
01P	0501054087	BLADE DISC	01
01Pa	0502011562	DC PST ACT/ULTR BOX	01
01Pb	0503010276	6206 BALL BEARING	02
01Pc	0521013610	BLADE DISC HUB AXLE	01
01Pd	0503030832	FLAT WASHER	02
01Pe	0503012417	SEAL 05175-GY	02
01Pf	0503011800	502062 CLAMPING RING (FOR AXLE)	02
01Pg	0503010691	1/4" GREASE FITTING	01
01Ph	0603030055	24" X 0.2" PLAIN DISC BLADE	01
01Pi	0502020641	BLADE DISC FLANGE	01
01Pj	0503010371	5/16" X 1" BOLT	06
01Pk	0503011444	5/16" SPRING WASHER	06
01PL	0503010337	5/16" NUT	06
01Q	0521015376	DUST CLOAK	02
01R	0511015346	FLAT WASHER	02
01S	0503011438	1" SPRING WASHER	02



BLADE DISC ASSYAST/MATIC E550 S0203

0501054090

Item	Code	Description	
01T	0521013510	3/4" AXLE DISC BLADE NUT	02
02	0502012026	BLADE DISC FIXER SUPPORT	01
03	0502012024	FIXER SUPPORT BUSHING	01
04	0503013184	5/8" X 2-3/4" BOLT G.8	01
05	0501011299	FLAT WASHER	01
06	0503010129	5/8" NUT	01
07	0521014574	3/4" X 6.3" X 5.1" FASTENE	02
08	0503010534	3/8" X 2-1/2" COTTERPIN	01
09	0503011198	3/4" X 6" BOLT	01

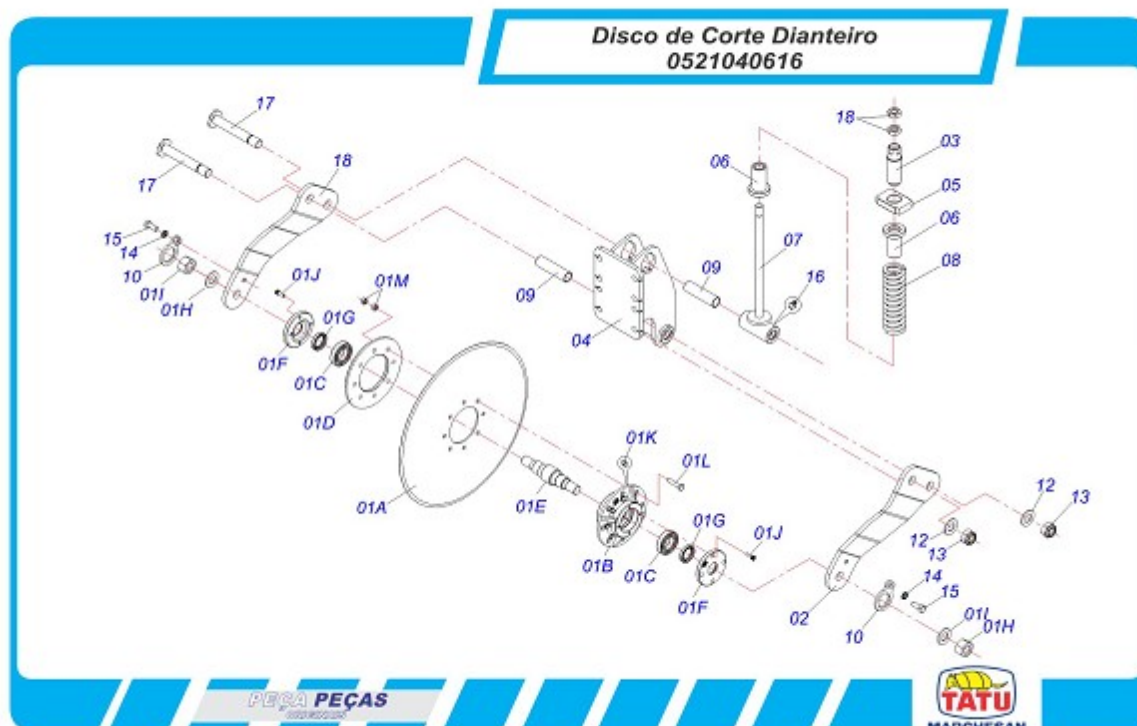

Item	Code	Description	
01	0501052013	24" BLADE DISC WITH HOUSING	01
01A	0511053370	24" X 7,5 BLADE DISC ASSY	01
01B	0502011478	DISC HUB	01
01C	0503011291	6209 BALL BEARING	02
01D	0521011824	BLADE DISC FALNGE OUTER	01
01E	0521012661	BLADE DISC AXLE HUB	01
01F	0521011477		02
01G	0503012106	00521-BR SEAL	02
01H	0501010087	1.1/4" UNC NUT	02
01I	0501017779	FLAT WASHER	02
01J	0503010134	3/8" X 1" BOLT	08
01K	0503010002	GREASE FITTING	01
01L	0503010905	1/2" X 2-1/4" BOLT	08
01M	0503010060	1/2" NUT	16
02	0571010670	RIGHT ARM OF THE BLADE DISC	01
03	0571010668	2" REGULATOR SPINDLE	01
04	0511068433	FRONT DISC BLADE FIXER	01
05	0571010667	SPRING LOCKNUT	01
06	0571010669	SLEEVE	02
07	0521062925	PRING ROD	01
08	0503031390	2.1"X10"X1/2" COMPRESSION SPRING	01
09	0551014549	32,54 SLEEVE	02
10	0501069637	AXLE NUT LOCK	02
11	0503013635	1" NUT	02
12	0501017779	FLAT WASHER	02
13	0503010044	1.1/4" UNF SELF ADJUSTING NUT	02
14	0503010027	5/8" SPRING WASHER	02
15	0503011267	5/8" X 1.1/2" BOLT	02
16	0503010002	GREASE FITTING	02
17	0521062926	COUPLING SHAFT	02
18	0521062924	RIGHT ARM THE BLADE DISC	01

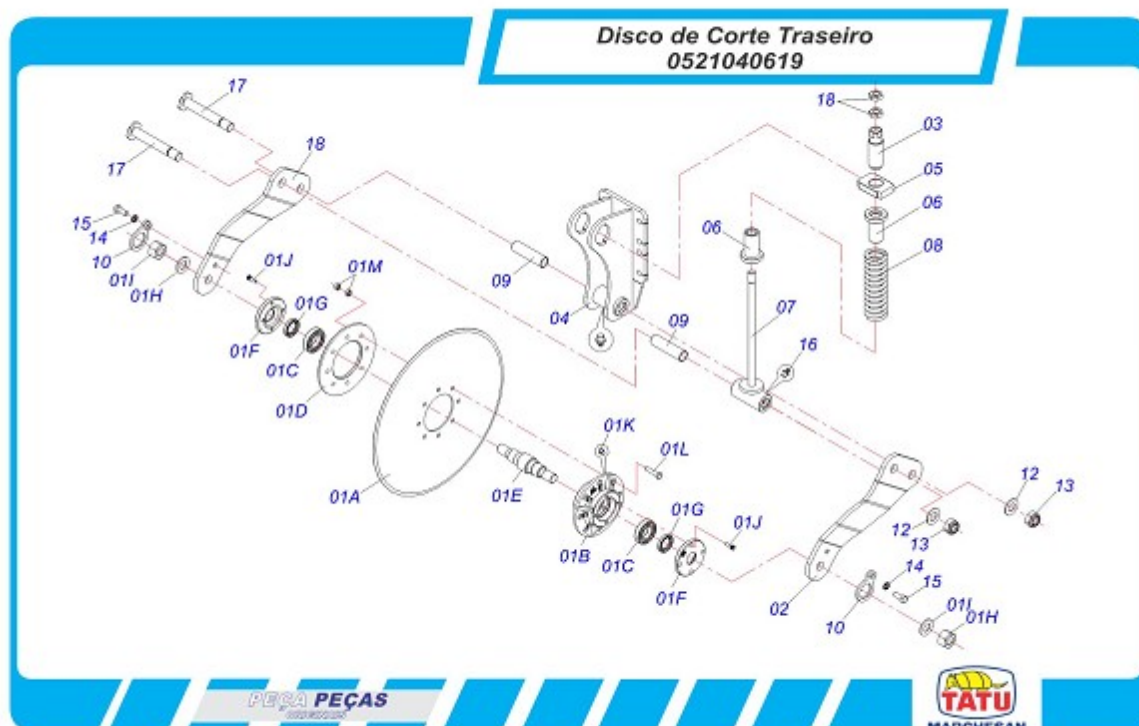

Item	Code	Description	
01	0501052013	24" BLADE DISC WITH HOUSING	01
01A	0511053370	24" X 7,5 BLADE DISC ASSY	01
01B	0502011478	DISC HUB	01
01C	0503011291	6209 BALL BEARING	02
01D	0521011824	BLADE DIC FALNGE OUTER	01
01E	0521012661	BLADE DISC AXLE HUB	01
01F	0521011477		02
01G	0503012106	00521-BR SEAL	02
01H	0501010087	1.1/4" UNC NUT	02
01I	0501017779	FLAT WASHER	02
01J	0503010134	3/8" X 1" BOLT	08
01K	0503010002	GREASE FITTING	01
01L	0503010905	1/2" X 2-1/4" BOLT	08
01M	0503010060	1/2" NUT	15
02	0571010670	RIGHT ARM OF THE BLADE DISC	01
03	0571010668	2" REGULATOR SPINDLE	01
04	0511068433	FRONT DISC BLADE FIXER	01
05	0571010667	SPRING LOCKNUT	01
06	0571010669	SLEEVE	02
07	0521062925	PRING ROD	01
08	0503031390	2.1"X10"X1/2" COMPRESSION SPRING	01
09	0551014549	32,54 SLEEVE	02
10	0501069637	AXLE NUT LOCK	02
11	0503013635	1" NUT	02
12	0501017779	FLAT WASHER	02
13	0503010044	1.1/4" UNF SELF ADJUSTING NUT	02
14	0503010027	5/8" SPRING WASHER	02
15	0503011267	5/8" X 1.1/2" BOLT	02
16	0503010002	GREASE FITTING	02
17	0521062926	COUPLING SHAFT	02
18	0521062924	RIGHT ARM THE BLADE DISC	01

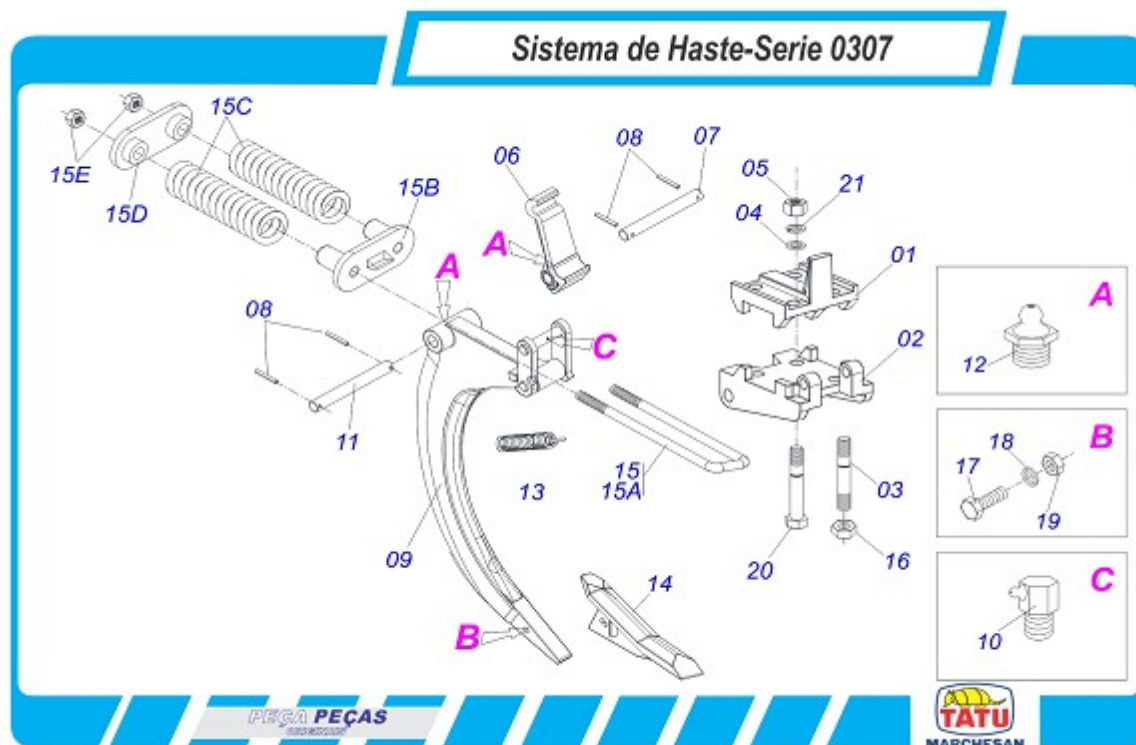

Item	Code	Description	
00	0501057701	SHANKS SYSTEM WITHOUT SPRING	01
01	0502011821	UPPER BASE	01
02	0502011822	LOWER BASE	02
03	0541010119	1.1/4" X 9.5" FASTENER	03
04	0501017779	FLAT WASHER	04
05	0503013094	1.1/4" X 0.8" HEX NUT	08
06	0502011823	SPRING FIXER ARM	01
07	0521017366	1.1" X 7.7" AXLE	01
08	0503011877	0.3" X 2.4" SPRING PIN	04
09	0511068743	SHANKS WITH ARM/DISARMENT	01
10	0503010004	GREASE FITTING	02
11	0521017367	1.2" X 10.1" AXLE	01
12	0503010002	GREASE FITTING	02
13	0503031574	6.9" X 0.8" X 0.1" EXTENSION SPRING	01
14	0502070083	SUBSOILER TIP	14
15	0501052884	1" X 23.03" FASTENER	01
15A	0521017662	1" X 23.03" FASTENER	01
15B	0502011824	FRONT FIXER SPRING	01
15C	0503031603	4" X 17" X 0.8" SPRING	02
15D	0502011825	REAR FIXER SPRING	01
15E	0503010340	1" UNF NUT	04
16	0501010087	1.1/4" UNC NUT	04
17	0503010850	7/16" X 3" BOLT	03
18	0501012803	FLAT WASHER	03
19	0503010244	7/16" NUT	03
20	0521017351	1-1/4" X 8" BOLT	02
21	0503010070	1.1/4" SPRING WASHER	02

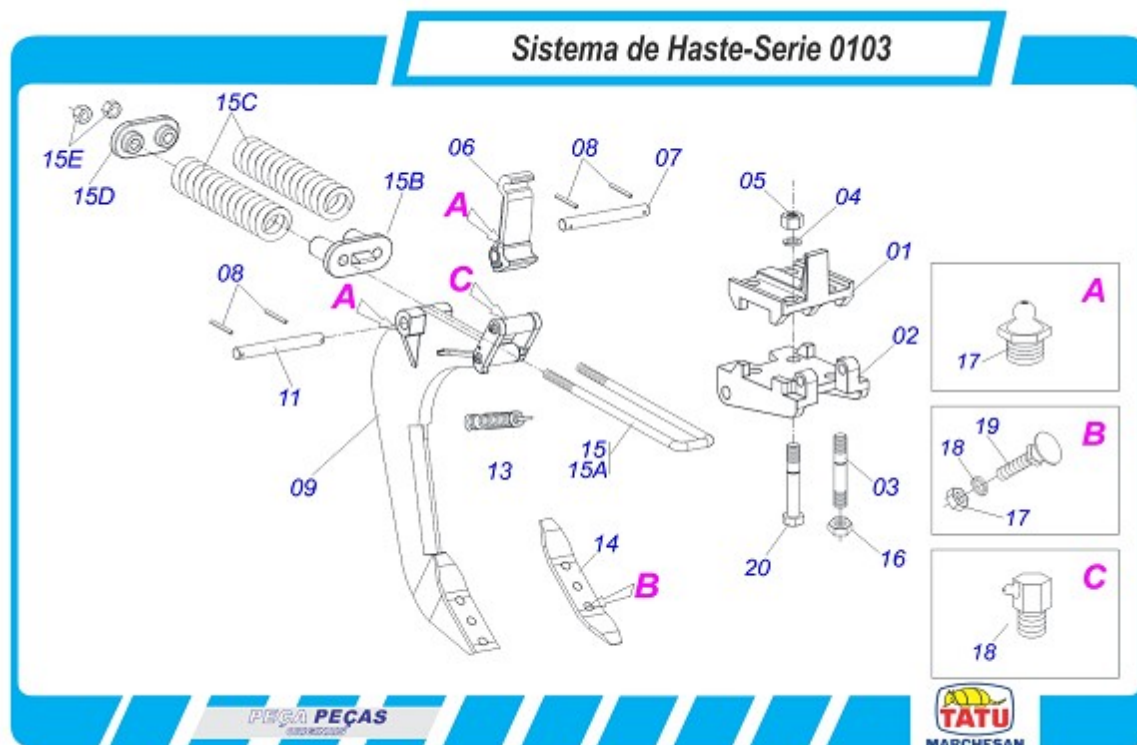

Item	Code	Description	
00	0501049334	SHANKS SYSTEM ASSY	
01	0502011821	UPPER BASE	01
02	0502011822	LOWER BASE	02
03	0541010119	1.1/4" X 9.5" FASTENER	03
04	0501017779	FLAT WASHER	04
05	0503013094	1.1/4" X 0.8" HEX NUT	08
06	0502011823	SPRING FIXER ARM	01
07	0521017366	1.1" X 7.7" AXLE	01
08	0503011877	0.3" X 2.4" SPRING PIN	04
09	0511064973	SUBSOILER ARM	01
10	0503010004	GREASE FITTING	02
11	0521017367	1.2" X 10.1" AXLE	01
12	0503010002	GREASE FITTING	02
13	0503031574	6.9" X 0.8" X 0.1" EXTENSION SPRING	01
14	0624010008	16" X 3" X 5/8" POINT SUBSOILER	14
15	0501052884	1" X 23.03" FASTENER	01
15A	0521017662	1" X 23.03" FASTENER	01
15B	0502011824	FRONT FIXER SPRING	01
15C	0503031603	4" X 17" X 0.8" SPRING	02
15D	0502011825	REAR FIXER SPRING	01
15E	0503010340	1" UNF NUT	04
16	0501010087	1.1/4" UNC NUT	04
17	0503012956	1/2" X 1-1/2" BOLT	03
18	0503010019	1/2" SPRING WASHER	03
19	0503010020	1/2" NUT	03
20	0521017351	1-1/4" X 8" BOLT	02

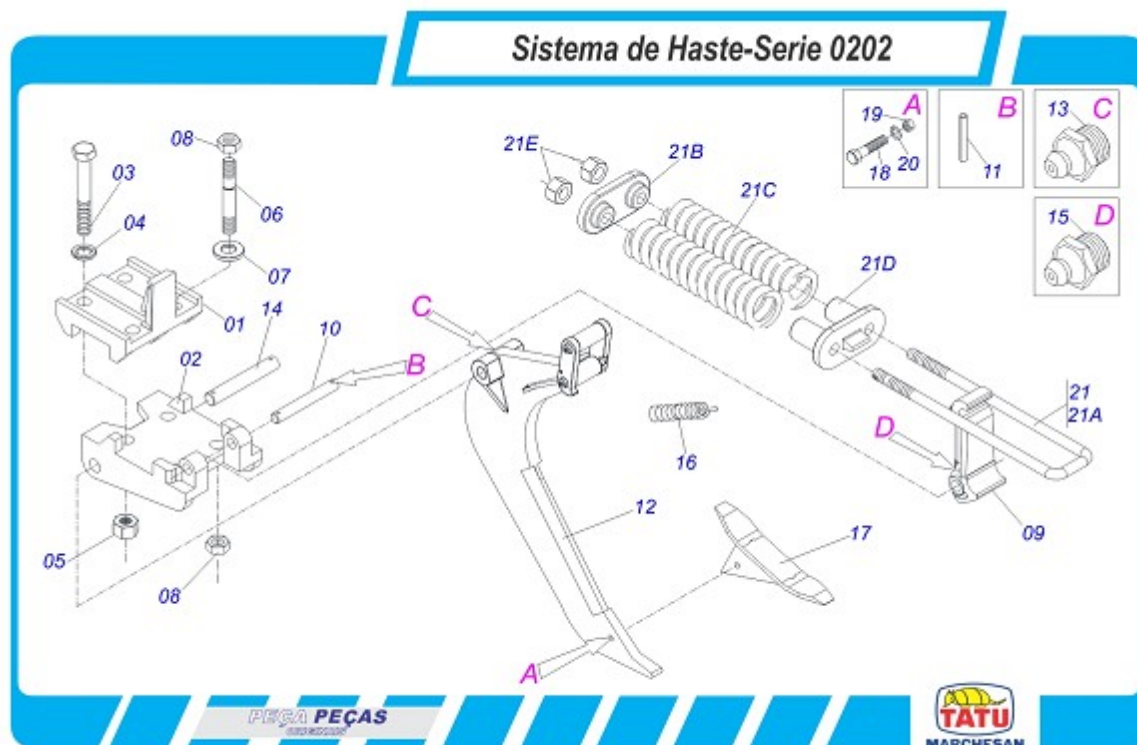

Item	Code	Description	
00	0511043370	SHANKS SYSTEM ASSY	
01	0502011821	UPPER BASE	01
02	0502011822	LOWER BASE	01
03	0521017351	1-1/4" X 8" BOLT	02
04	0503010070	1.1/4" SPRING WASHER	02
05	0503010352	1.1/4" UNF NUT	02
06	0541010119	1.1/4" X 9.5" FASTENER	02
07	0501017779	FLAT WASHER	04
08	0503013094	1.1/4" X 0.8" HEX NUT	08
09	0502011823	SPRING FIXER ARM	01
10	0521017366	1.1" X 7.7" AXLE	01
11	0503011877	0.3" X 2.4" SPRING PIN	04
12	0511064522	SUBSOILER ARM	01
13	0503010004	GREASE FITTING	02
14	0521017367	1.2" X 10.1" AXLE	01
15	0503010002	GREASE FITTING	02
16	0503031574	6.9" X 0.8" X 0.1" EXTENSION SPRING	01
17	0511064539	POINT SUBSOILER	01
18	0503011172	1/2" X 2-1/2" BOLT	01
19	0503010060	1/2" NUT	01
20	0503010019	1/2" SPRING WASHER	01
21	0501052884	1" X 23.03" FASTENER	01
21A	0521017662	1" X 23.03" FASTENER	01
21B	0502011825	REAR FIXER SPRING	01
21C	0503031603	4" X 17" X 0.8" SPRING	02
21D	0502011824	FRONT FIXER SPRING	01
21E	0503010340	1" UNF NUT	04

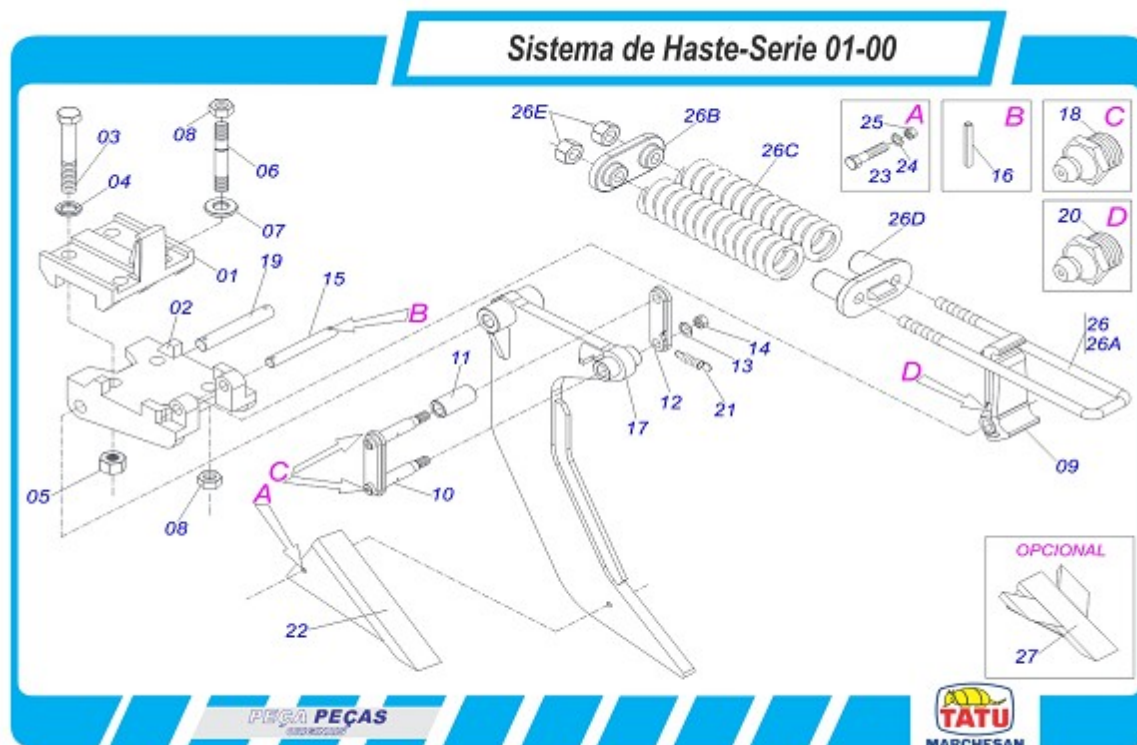

Item	Code	Description	
00	0511043371	SHANKS SYSTEM	
01	0502011821	UPPER BASE	01
02	0502011822	LOWER BASE	01
03	0521017351	1-1/4" X 8" BOLT	02
04	0503010070	1.1/4" SPRING WASHER	02
05	0503010352	1.1/4" UNF NUT	02
06	0541010119	1.1/4" X 9.5" FASTENER	02
07	0501017779	FLAT WASHER	04
08	0503013094	1.1/4" X 0.8" HEX NUT	08
09	0502011823	SPRING FIXER ARM	01
10	0511061581	RIGHT FIXER W/AXLE	01
11	0521017365	1" X 1.8" X 3.7" SLEEVE	01
12	0511061580	LEFT FIXER	01
13	0503011447	7/8" SPRING WASHER	02
14	0503010417	7/8" NUT	02
15	0521017366	1.1" X 7.7" AXLE	01
16	0503011877	0.3" X 2.4" SPRING PIN	04
17	0511061582	SUBSOILER ARM	01
18	0503010004	GREASE FITTING	02
19	0521017367	1.2" X 10.1" AXLE	01
20	0503010002	GREASE FITTING	02
21	0503031574	6.9" X 0.8" X 0.1" EXTENSION SPRING	01
22	0501069818	SUBSOILER TIP	01
23	0503011172	1/2" X 2-1/2" BOLT	01
24	0503010019	1/2" SPRING WASHER	03
25	0503010060	1/2" NUT	01
26	0501052884	1" X 23.03" FASTENER	01
26A	0521017662	1" X 23.03" FASTENER	01
26B	0502011825	REAR FIXER SPRING	01
26C	0503031603	4" X 17" X 0.8" SPRING	02
26D	0502011824	FRONT FIXER SPRING	01
26E	0503010340	1" UNF NUT	04
27	0501069385	SUBSOILER TIP CUERPO	01



Item	Code	Description	
00	0511051080	11L15 WHITH RIGHT WHEEL ASSY	01 00
00A	0511051081	11L15 WITH LEFT WHEEL SET	00 01
01	0511065423	HUB SUPPORT	01 01
02	0502012400	ROW FERTILIZER FIXER	02 02
03	0501010452	5/8" X 5" BOLT	04 04
04	0501012140	FLAT WASHER	04 04
05	0503010027	5/8" SPRING WASHER	09 09
06	0503010013	5/8" NUT	11 11
07	0502011308	WHELL FASTENER	01 01
08	0503013185	3/4"UNC X 5.1/2"BOLT	02 02
09	0501010322	FLAT WASHER	02 02
10	0503010023	3/4" SPRING WASHER	02 02
11	0503010014	3/4" NUT	02 02
12	0531019365	FASTENING PLATE	01 01
13	0503010920	1/2" X 1.1/2" BOLT	10 10
14	0511017302	FLAT WASHER	11 11
15	0503010019	1/2" SPRING WASHER	20 20
16	0503010060	1/2" NUT	06 06
17	0501048672	CHAIN TIGHTENER ASSY	01 01
17A	0521012529	CHAIN TIGHTENER AXLE	01 01
17B	0503030402	PULLEY	01 01
17C	0503010302	501019 CLAMPING RING (FOR AXLE)	01 01
17D	0503010002	GREASE FITTING	02 02
17E	0511017302	FLAT WASHER	01 01
17F	0503010019	1/2" SPRING WASHER	01 01
17G	0503010060	1/2" NUT	01 01
18	0511065935	RIGHT WHEEL FORK	01 00
19	0511065934	LEFT WHEEL FORK	00 01
20	0501110625	WHEEL PIVOT BEARING	02 02
21	0561013021	BEARING INNER LOK	02 02
22	0561013022	BEARING EXTERNAL LOCK	02 02
23	0503010398	501082 CLAMPING RING (FOR AXLE)	02 02
24	0561013020	KM 12 NUT	02 02



STAC 5HE DC RD

0909094348

Item	Code	Description	
25	0501055275	11L15 HUB WITH TIRE WHEEL ASSY	01 01
26	0521012190	AXLE LOCK	02 02
27	0503011188	M16 X 2 X 50 BOLT	02 02
28	0511043969	44,45 X 101,6 HYDRAULIC CYLINDER	01 01
29	0511066351	CYL HYDR FIXER FRANGE	02 02
30	0541014046	SPRING HITCH	01 01
31	0503010834	1/2" X 1" BOLT	03 03
32	0503010395	1/2" X 1-1/4" BOLT	04 01
33	0521010546	1.2" X 5.7" COUPLING SHAFT	01 01
34	0501017779	FLAT WASHER	02 02
35	0503010523	1/4" X 2" COTTERPIN	01 01
36	0511064769	15Z GEAR WITH AXLE	01 01
37	0511061809	15Z GEAR WITH COUPLING	01 01
38	0503011103	7/16" X 2-1/2" BOLT	01 01
39	0503010180	7/16" SPRING WASHER	01 01
40	0503010244	7/16" NUT	01 01
41	0503010004	GREASE FITTING	02 01
42	0501053522	WHEEL CHAIN TIGHTENER	01 01
42A	0551018252	CHAIN TIGHTENER AXLE	01 01
42B	0502012018	CHAIN TIGHTENER BEARING	01 01
42C	0503012882	BALL BEARING	01 01
42D	0503011945	503050 CLAMPING RING (FOR AXLE)	01 01
42E	0511014513	1" X 0.6" X 0.4" ARTUCULAT SLEEVE	01 01
43	0531018654	CHAIN TIGHTENER SUPPORT	01 01
44	0531018653	CHAIN TIGHTENER MINOR SUPPORT	01 01
45	0531016916	BEARING BUSHING	02 02
46	0511014513	1" X 0.6" X 0.4" ARTUCULAT SLEEVE	01 01
47	0503010899	5/8" X 2-1/4" BOLT	01 01
48	0501013491	5/8" TENSIONER SPRING	01 01
49	0503031103	0.9" X 4.1" X 0.1" TRACTION SPRING	01 01
50	0501110025	AGRICULTURAL BEARING	01 01
51	0503010257	1/8" X 1" COTTERPIN	01 01
52	0511040424	RH TRANSMISSION DRIVING ASSY	01 00
53	0511061837	PIVOT ARM ASSY	01 01
54	0501010984	FLAT WASHER	02 02
55	0503010140	1/8" X 3/4" COTTERPIN	03 03
56	0511061896	RATCHET DISMANTLE SUPPORT	01 01
57	0503010395	1/2" X 1-1/4" BOLT	02 02
58	0521015800	REAR LEVER FASTENER	01 01
59	0503010025	3/8" SPRING WHASHER	01 01
60	0503010026	3/8" NUT	01 01
61	0541012066	ASSEMBLE AND DISASSEMBLE ARM RIGHT	01 01
62	0541012164	ASSEMBLE AND DISASSEMBLE ARM LEFT	01 01
63	0521018560	HANDLE LEVER	01 01
64	0503030242	0.8" X 4.7" X 0.08" TRACTION SPRING	01 01
65	0503012708	2050 CHAIN X 34 LINKS + REDUCTION	01 01
66	0503012570	CHAIN 2050 X 2.8" LINK + MENDING	01 01
67	0531016051	CARRY-WHEEL CHAIN PROTECTION CAP	01 00
68	0541012543	LEFT CARRY-WHEEL CHAIN PROTECTION	00 01
69	0501013772	1/2" X 3-1/4" BOLT	02 02
70	0521013022	6.7" X 2.1" TRANSPORT LOCK	02 02
71	0501047885	1.18" ROD STOP	02 02
72	0501047886	1.38" ROD STOP	02 02
73	0501047887	1.57" ROD STOP	02 02
74	0501068994	0.3" X 3.1" LOCK PIN	02 02
75	0503030168	HAIR PIN	02 02
76	0501051597	TRANSMISSION LEFT DRIVING	00 01

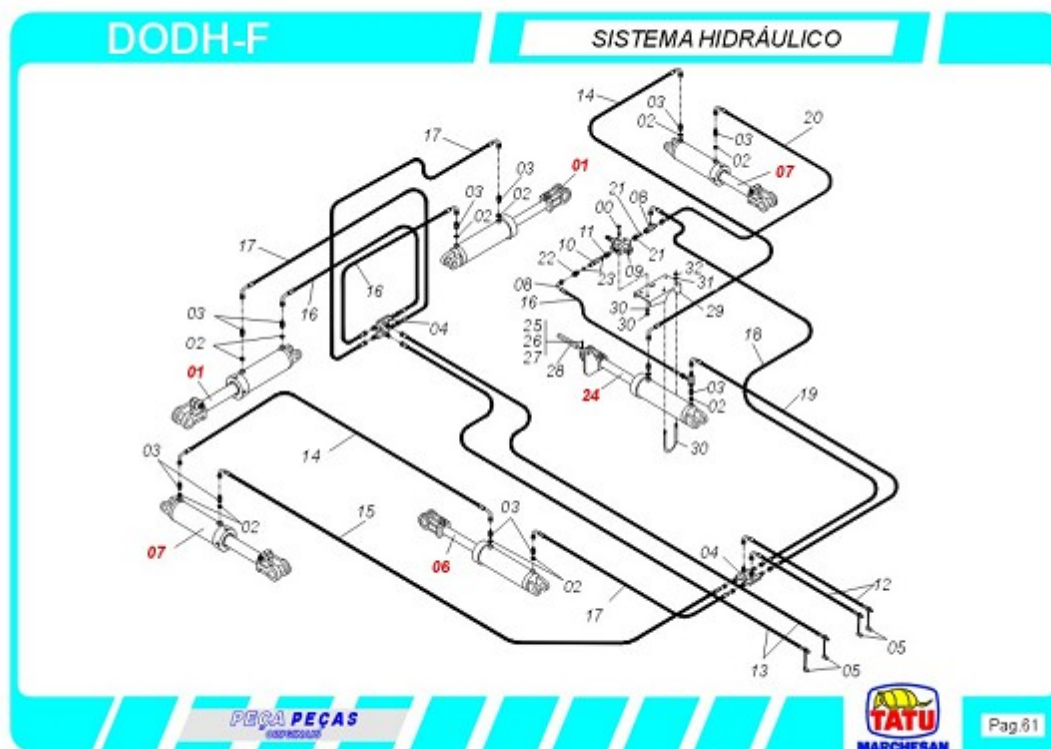

Item	Code	Description	
01	0511045565	HYDRAULIC CYLINDER	02
02	0503010190	2-114 N 3006-9B O'RING	12
03	0501010617	3/4" NIPPLE	12
04	0501068706	DOUBLE CONNECTION	02
05	0501053834	QUICK CONECTION (MALE) 1/2NPT	04
06	0511045695	HYDRAULIC CYLINDER 203 BP	02
07	0511045694	44,45 X 85,7 X 515 X 203 HYDRAULIC CYLINDER	02
08	0503011968	"T" ADAPTOR WITH GIRAT NUT 3/8	02
09	0503014462		01
10	0503014463		01
11	0551014612		01
12	0501080878	3/8" X 165" TC-TM HOSE ASSY	02
13	0501081214	3/8" X 6800 TR-TM HOSE	02
14	0501080718	3/8" X 5000 TC-TC HOSE ASSY	02
15	0501080725	3/8 X 5300 TR-TC HOSE ASSY	01
16	0501080375	3/8" X 23" TR-TC HOSE ASSY	03
17	0501080026		03
18	0501080461	3/8" X 1800 HOSE ASSY	01
19	0501080436	3/8" X 59" TR-TC HOSE ASSY	03
20	0501081225	HOSE 3/8 X 5000 TR-TC	01
21	0551014611		01
22	0511010111	7/8" NIPPLE	01
23	0503010045	2-116 N 3006-9B O'RING	01
24	0511047229	HYDRAULIC CYLINDER	01
25	0503011094	3/8" X 2" BOLT C C S I 12.9	01
26	0503010025	3/8" SPRING WHASHER	01
27	0503010026	3/8" NUT	01
28	0501058414		01
29	0521060343		01
30	0551019514		02
31	0501010080	3/8" X 1-1/2" BOLT	03

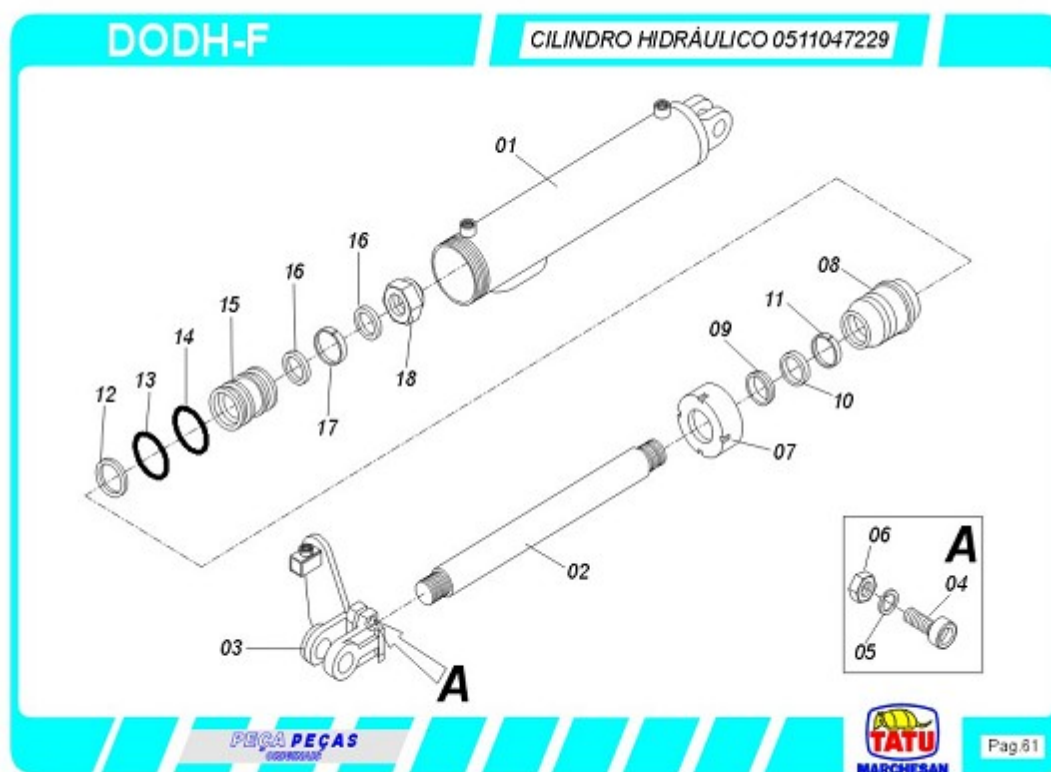

Item	Code	Description	
00	0511047229	HYDRAULIC CYLINDER	01
01	0511068373	101,6 X 203 CYLINDER CASE	01
02	0531018245	EXTENDING BODY	01
03	0511069895		01
04	0503011094	3/8" X 2" BOLT C C S I 12.9	01
05	0503010025	3/8" SPRING WHASHER	01
06	0503010026	3/8" NUT	01
07	0502010017	4" HEAD	01
08	0502011250	2.1 X 4" RING SUPPORT	01
09	0503010319	D-2125 SCRAPER	01
10	0503010314	GASKET	01
11	0503010973	W2-2500-500 PK RING G.E	01
12	0503011061	8-342 BACK-UP RING	01
13	0503010338	2-342 N 3006-9B O'RING	01
14	0503010345	2-218 N 3006-9B O'RING	01
15	0502011249	2.1 X 4" PISTON	01
16	0503010043	PACKING 3750-3250	02
17	0503010994	W2-4000-500 PK RING G.E	01
18	0503012726	RUBBER RING	01
19	0503012725	GASKET	01
20	0503010817	1.1/4" UNF SELF ADJUSTING NUT	01
21	0501034420	HYDRAULIC CYLINDER REPAIR KIT	01

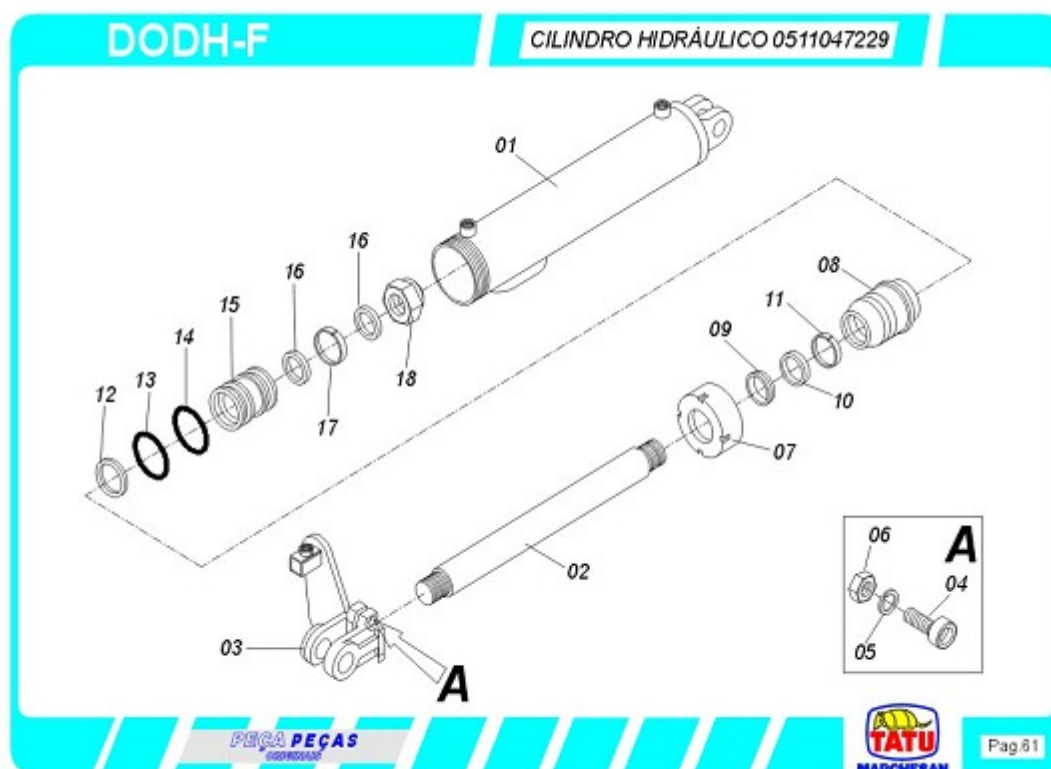

Item	Code	Description	
01	0511068432	BLADE DISC REAR FIXER	01
02	0511068434	PRING ROD	01
03	0503031390	2.1"X10"X1/2" COMPRESSION SPRING	01
04	0551014554	28,58 X 50 SLEEVE	02
05	0551014553	REGULATOR SPINDLE	01
06	0551014552	SPRING LOCKNUT	01
07	0503013635	1" NUT	02
08	0551014558	ARM BLADE DISC	02
09	0551014551	27 SLEEVE	01
10	0511016281	3/4" X 8" BOLT	01
11	0503010023	3/4" SPRING WASHER	01
12	0503010014	3/4" NUT	01
13	0551014549	32,54 SLEEVE	01
14	0503011439	1.1/4" SPRING WASHER	01
15	0501010087	1.1/4" UNC NUT	01
16	0501052013	24" BLADE DISC WITH HOUSING	01
16A	0603030044	24" X 0.2" FLAT PLAIN DISC	01
16B	0502011478	DISC HUB	01
16C	0503011291	6209 BALL BEARING	02
16D	0503012106	00521-BR SEAL	02
16E	0521012661	BLADE DISC AXLE HUB	01
16F	0502011477	BLADE DISC HOUSIG CP	02
16G	0503010134	3/8" X 1" BOLT	08
16H	0521011824	BLADE DIC FALNGE OUTER	01
16I	0503010905	1/2" X 2-1/4" BOLT	08
16J	0503010060	1/2" NUT	16
16K	0521012664	FLAT WASHER	02
17	0501069637	AXLE NUT LOCK	02
18	0503010962	5/8" X 1-1/4" BOLT	02
19	0503010027	5/8" SPRING WASHER	02
20	0503010002	GREASE FITTING	01
21	0503014765	1.1/4" UNC BOLT	01

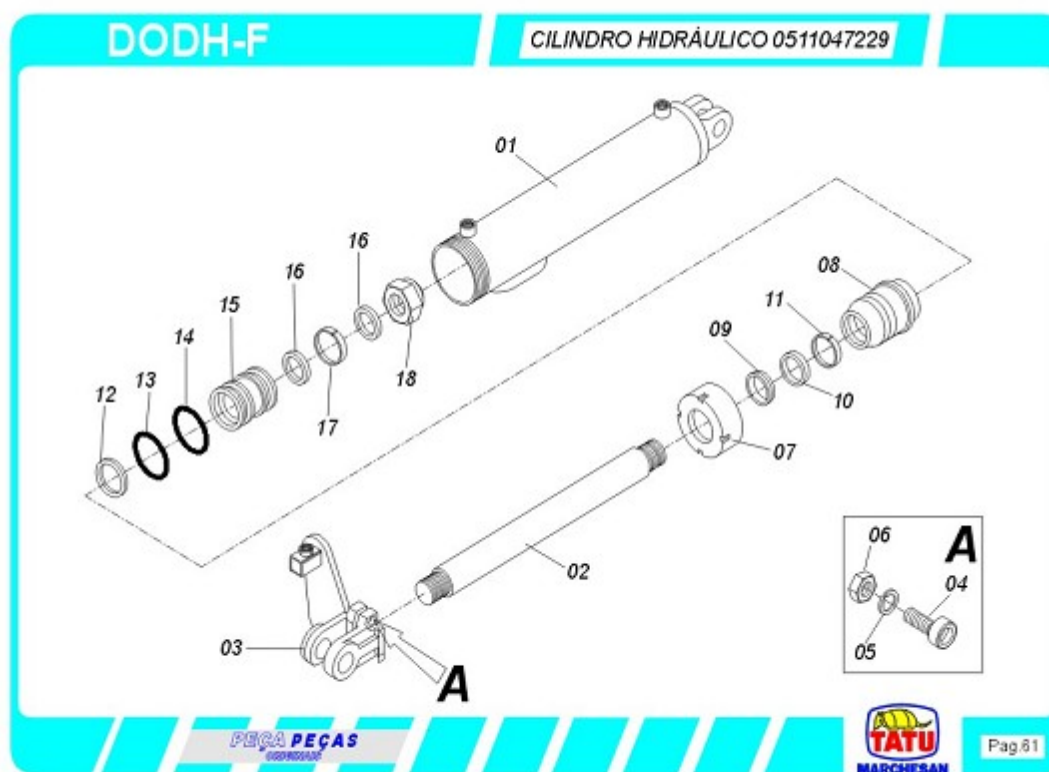

Item	Code	Description	
00	0511045694	44,45 X 85,7 X 515 X 203 HYDRAULIC CYLINDER	
01	0511068214	101,60 X 930 CYLINDER CASE	01
02	0501018532	1.7" X 15.6" TURNBUCLE	01
03	0503010042	2-214 N 3006-9B O'RING	01
04	0502040747	FORK	01
05	0503011094	3/8" X 2" BOLT C C S I 12.9	01
06	0503010025	3/8" SPRING WHASHER	01
07	0503010026	3/8" NUT	01
08	0502010781	RING SUPPORT	01
09	0503010761	D-1750 SCRAPER RING	01
10	0503010990	GASKET	01
11	0503010949	W2-2000-500 PK RING G.E	01
12	0503010976	2-336 N 3006-9B O'RING	01
13	0503011060	8-336 BACK-UP RING	01
14	0502011847	1.7" X 3.4" PISTON	01
15	0503012509	GASKET	02
16	0503010948	W4-3346-590 PK RING G.E	01
17	0503010063	1" SELF-ALIGNING NUT	01
18	0502010993	DETACHABLE COVER	01
19	0511018115	1.8" X 0.1" 0.7" BUSHING	01
20	0503011148	3/8" X 1/2" BOLT	01

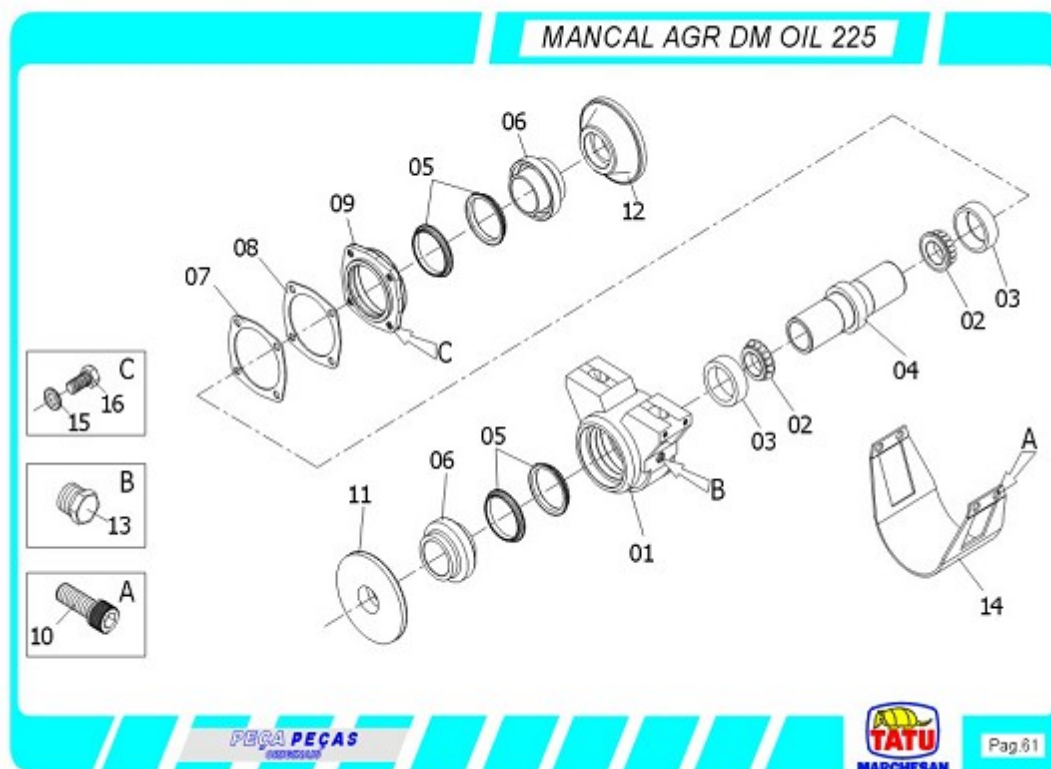

Item	Code	Description	
00	0501043029	AGR DM OL 225X 1.1/2 BEARING ASSY	01
01	0502010717	HOUSING DM	01
02	0503013269	368 CONE	02
03	0503013268	362A CAP	02
04	0502040444	AXLE	01
05	0503030026	SEAL # LP JB-253	02
06	0502010731	SEAL RETAINER	02
07	0503030013	4.4" X 3.5" X 0.004" JOINT	02
08	0503030684	4.4" X 3.5" X 0.004" JOINT	01
09	0502020424	HOUSING CAP DM	01
10	0503010134	3/8" X 1" BOLT	04
11	0502010694	OUTER FLANGE	01
12	0502010715	INNER FLANGE	01
13	0503010856	3/8" OIL PLUG	02
14	0511010829	BEARING GUARD	01
15	0503011443	3/8" SPRING WASHER	04
16	0503010256	3/8" X 3/4" BOLT	04



MARCHESAN

MARCHESAN IMPLEMENTOS E MÁQUINAS AGRÍCOLAS TATU S.A.

AV. Marchesan, 1979 - Post office box, 131 - CEP 15994-900 - Matão - SP - Brazil

Phone +55 16.3382-8282

(FAX Parts) + 55 16.3382. 8297 - (Export) + 55 16.3382.1003

e.mail: tatu@marchesan.com.br www.marchesan.com.br

Drafting and Illustration = GASPARI
e.mail = jgaspari@marchesan.com.br

**ORIGINAL PARTS
TATU**



MARCHESAN